

Low Voltage General Purpose Motors

Aluminium motor section



Making you more competitive

ABB's General purpose motor is designed for use in general industry, meeting the demands of standard applications for OEM's. Motors are readily available from central stock locations and distributors around the world. The motors have high build quality, are available with all the features needed by the OEM market and can be modified to meet most specifications.



ABB (www.abb.com) is a leader in power and automation technologies that enable utility and industry customers to improve performance while lowering environmental impacts. The ABB Group of companies operates in around 100 countries and employs around 103,000 people.

Low Voltage General Purpose Motors

Sizes 56 to 400, from 0.055 to 630 kW

	Contents	Page	
1	General information	4	1
2	Aluminum motors	11	2
3	Steel motors	81	3
4	Cast iron motors	113	4
5	Open drip proof motors	147	5
6	Global motors	167	6
7	Brake motors	193	7
8	Single phase motors	219	8
9	Integral motors	237	9

ABB reserves the right to change the design, technical specification and dimensions without prior notice.

This pdf includes section 2, see complete pdf for other sections.

General information

Standards

ABB motors are of the totally enclosed and open drip proof, single or three phase squirrel cage type, built to comply with international IEC and EN standards. Motors conforming to other national and international specifications are also available on request.

All production units are certified to ISO 9001 international quality standard as well ISO 14000 environmental standard and confirm to all applicable EU Directives.

IEC / EN

Electrical	Mechanical
IEC/EN 60034-1	IEC 60072
IEC/EN 60034-2	IEC/EN 60034-5
IEC 60034-8	IEC/EN 60034-6
IEC 60034-12	IEC/EN 60034-7
	IEC/EN 60034-9
	IEC 60034-14

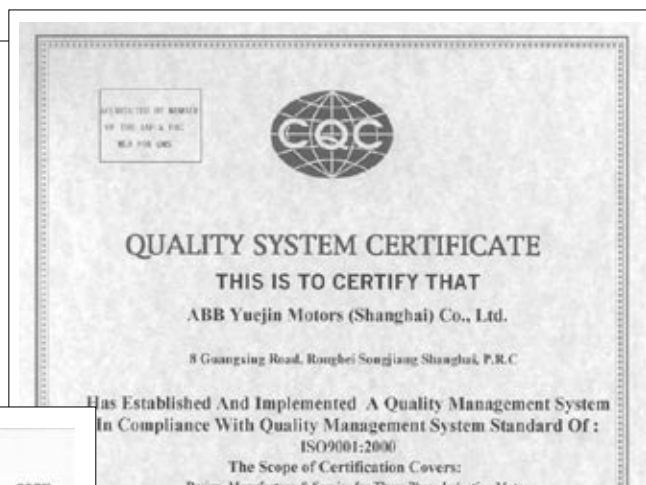

Motors for EU motor efficiency levels

A Europe-wide agreement will ensure that the efficiency levels of electric motors manufactured in Europe are clearly displayed. In contrast to the American legislation on motor efficiency the European agreement does not establish mandatory efficiency levels.

It basically establishes three classes giving motor manufacturers an incentive to qualify for a higher class.

ABB is one of only a handful of leading motor manufacturers in Europe to have a motor range to meet or exceed the minimum efficiencies stated in the highest level of the EU agreement of LV motors.

These efficiency levels apply to 2- and 4-pole, three phase squirrel cage induction motors rated for 400V, 50Hz with S1 duty class with the output 1.1 to 90 kW, which

account for the largest volume on the market.

The efficiency of motors from different manufacturers are collated in a database, EURODEEM, published by the European Commission. It is accessible over the Internet at <http://iamest.jrc.it/projects/eem/eurodeem.htm>.



EU efficiency classes for 2-pole motors

Output kW	2-pole Boarderline	
	EFF2/EFF3	EFF1/EFF2
1.1	76.2	82.8
1.5	78.5	84.1
2.2	81.0	85.6
3	82.6	86.7
4	84.2	87.6
5.5	85.7	88.6
7.5	87.0	89.5
11	88.4	90.5
15	89.4	91.3
18.5	90.0	91.8
22	90.5	92.2
30	91.4	92.9
37	92.0	93.3
45	92.5	93.7
55	93.0	94.0
75	93.6	94.6
90	93.9	95.0

ABB Three phase induction motors, 400 V 50 Hz - EU motor efficiency levels

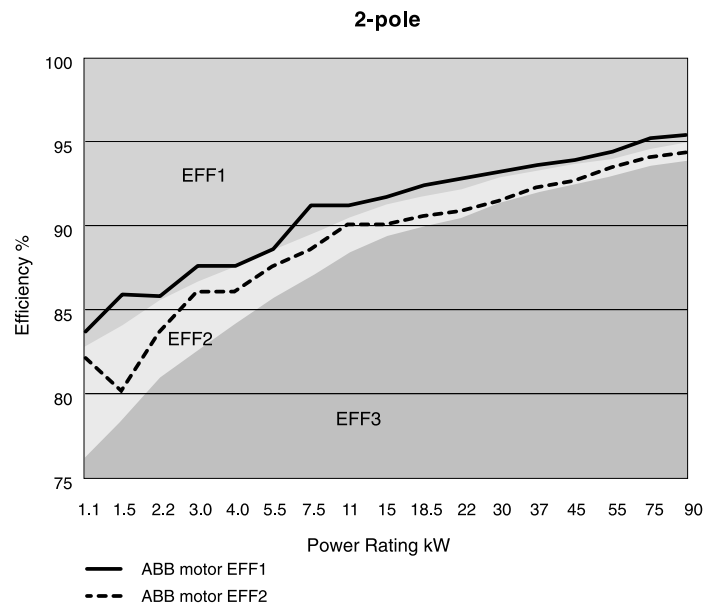

EU efficiency classes for 4-pole motors

Output kW	4-pole Boarderline	
	EFF2/EFF3	EFF1/EFF2
1.1	76.2	83.8
1.5	78.5	85.0
2.2	81.0	86.4
3	82.6	87.4
4	84.2	88.3
5.5	85.7	89.2
7.5	87.0	90.1
11	88.4	91.0
15	89.4	91.8
18.5	90.0	92.2
22	90.5	92.6
30	91.4	93.2
37	92.0	93.6
45	92.5	93.9
55	93.0	94.2
75	93.6	94.7
90	93.9	95.0

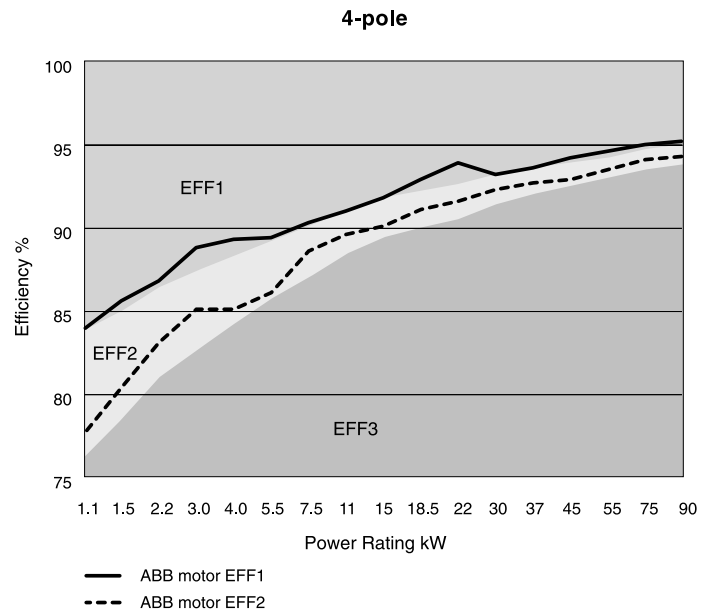

General technical specification

Mechanical and electrical design

Mounting arrangements

1

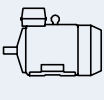
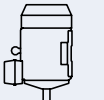
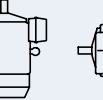
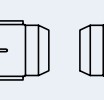
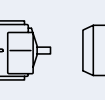
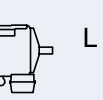
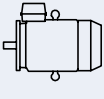
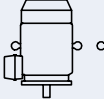
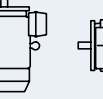
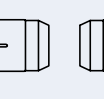
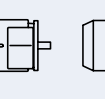
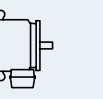
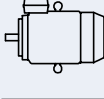
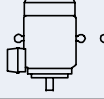
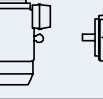
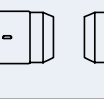
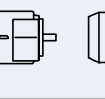
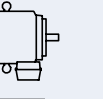
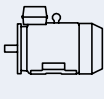
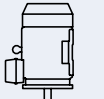
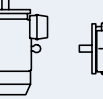
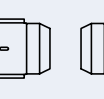
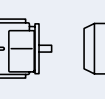
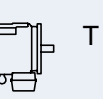
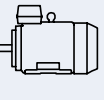
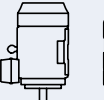
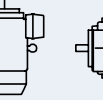
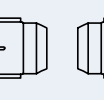
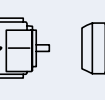
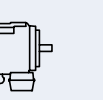
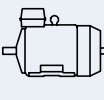
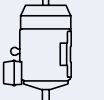
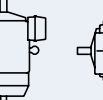
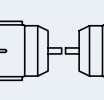
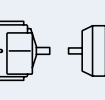
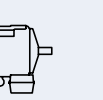
	Codell/Codell						Product code pos. 12
Foot-mounted motor.	IM B3 IM 1001	IM V5 IM 1011	IM V6 IM 1031	IM B6 IM 1051	IM B7 IM 1061	IM B8 IM 1071	A = foot-mounted, term.box top R = foot-mounted, term.box RHS L = foot-mounted, term.box LHS
							
Flange-mounted motor, large flange	IM B5 IM 3001	IM V1 IM 3011	IM V3 IM 3031	*) IM 3051	*) IM 3061	*) IM 3071	B = flange mounted, large flange
							
Flange-mounted motor, small flange	IM B14 IM 3601	IM V18 IM 3611	IM V19 IM 3631	*) IM 3651	*) IM 3661	*) IM 3671	C = flange mounted, small flange
							
Foot- and flange-mounted motor with feet, large flange	IM B35 IM 2001	IM V15 IM 2011	IM V36 IM 2031	*) IM 2051	*) IM 2061	*) IM 2071	H = foot/flange-mounted, term.box top S = foot/flange-mounted, term.box RHS T = foot/flange-mounted, term.box LHS
							
Foot- and flange-mounted motor with feet, small flange	IM B34 IM 2101	IM V17 IM 2111	IM 2131	IM 2151	IM 2161	IM 2171	J = foot/flange-mounted, small flange
							
Foot-mounted motor, shaft with free extensions	IM 1002	IM 1012	IM 1032	IM 1052	IM 1062	IM 1072	
							
*) Not stated in IEC 60034-7.							

Cooling

Designation system concerning methods of cooling refers to standard IEC 60034-6.

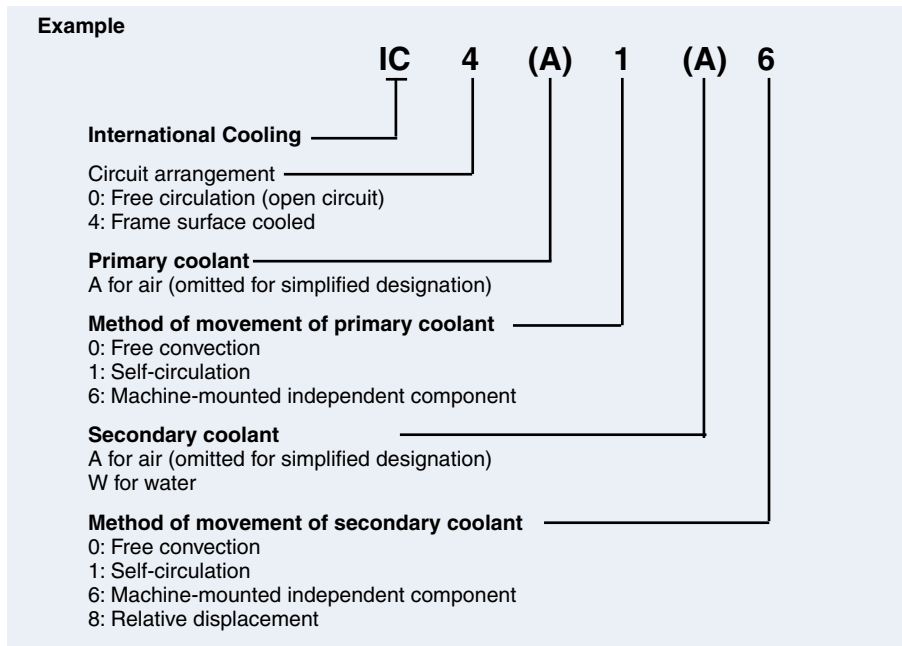

Degrees of protection: IP code/IK code

Classification of degrees of protection provided by enclosures of rotating machines are refers to:

- Standard IEC 60034-5 or EN 60529 for IP code
- Standard EN 50102 for IK code

IP protection:

Protection of persons against getting in contact with (or approaching) live parts and against contact with moving parts inside the enclosure. Also

protection of the machine against ingress of solid foreign objects. Protection of machines against the harmful effects due to the ingress of water

IK code :

Classification of degrees of protection provided by enclosure for motors against external mechanical impacts.

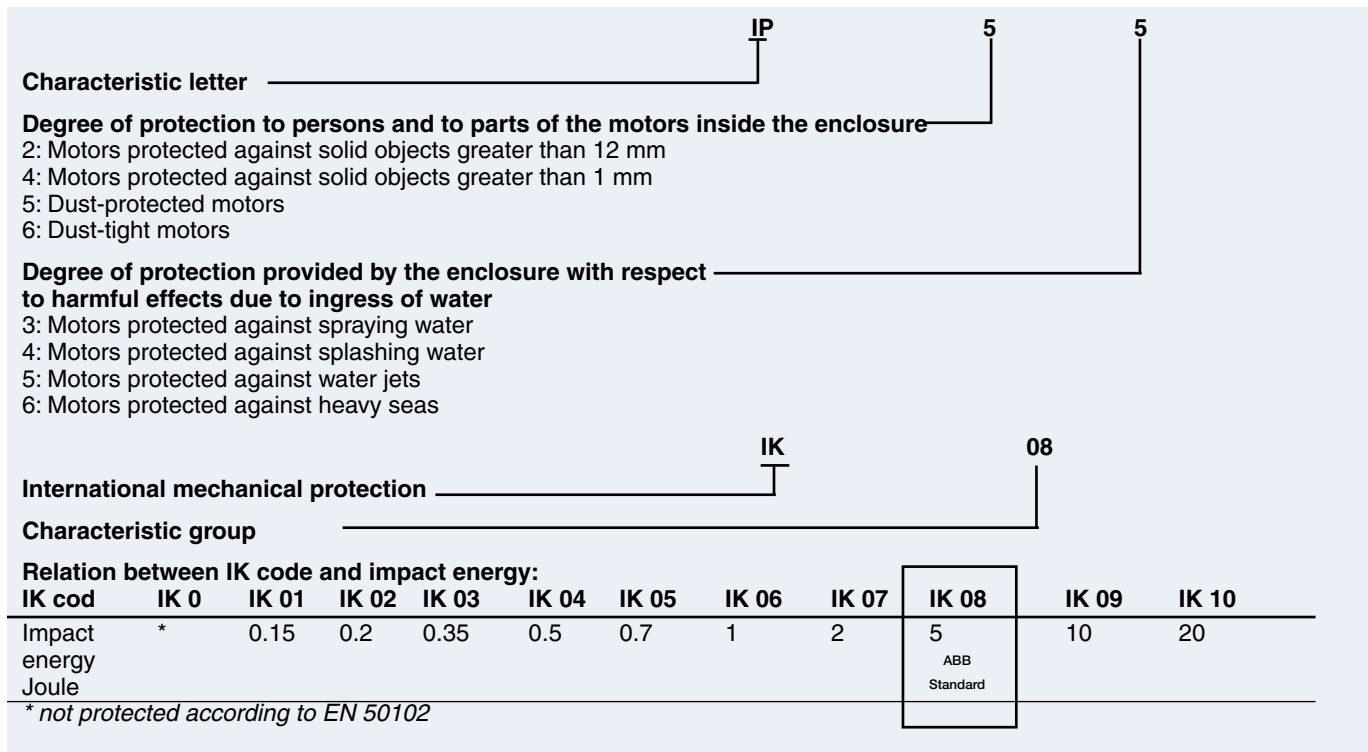

Insulation

ABB uses class F insulation systems, which, with temperature rise B, is the most common requirement among industry today.

The use of Class F insulation with Class B temperature rise gives ABB products a 25° C safety margin. This can be used to increase the loading for limited periods, to operate at higher ambient temperatures or altitudes, or with greater voltage and frequency tolerances. It can also be used to extend insulation life. For instance, a 10 K temperature reduction will extend the insulation life.

Class F insulation system

- Max ambient temperature 40° C
- Max permissible temperature rise 105 K
- Hotspot temperature margin + 10 K

Class B rise

- Max ambient temperature 40° C
- Max permissible temperature rise 80 K
- Hotspot temperature margin + 10 K

Insulation system temperature class

- Class F 155° C
- Class B 130° C
- Class H 180° C

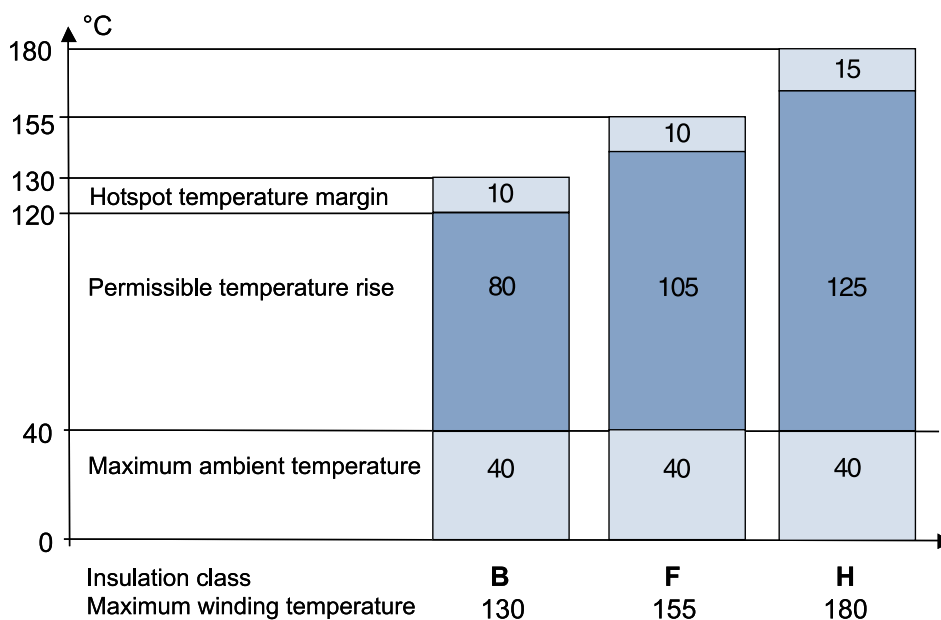

Safety margins per insulation class

Frequency converter drives

Squirrel cage induction motors offer excellent availability, reliability and efficiency. With a frequency converter – a variable speed drive (VSD) – the motor will deliver even better value. A variable speed drive motor can be started softly with low starting current, and the speed can be controlled and adjusted to suit the application demand without steps over a wide range. Also the use of a frequency converter together with a squirrel cage motor usually leads to remarkable energy and environmental savings.

However, all motors are not suitable for variable speed drive. There are several points that have to be taken into account in the design and selection of the motor, if it is intended for variable speed operation.

Within the General purpose motor range ABB offers motors designed for both Direct On Line (DOL) and variable speed applications.

For more demanding applications the use of ABB Process performance motors is recommended.

The following points must be taken into account, when selecting a motor to a variable speed drive:

1. Dimensioning

The voltage (or current) fed by the frequency converter is not purely sinusoidal. This may increase the losses, vibration, and noise of the motor. Furthermore, a change in the distribution of the losses may affect to the temperature rise of the motor. In each case, the motor must be correctly sized according to the instructions supplied with the selected frequency converter.

When using ABB converters, please use ABB's DriveSize dimensioning programme or the loadability curves of the corresponding converter type for sizing the motors. The loadability curve for applicable General purpose motors used with ABB's ACS 600- and ACS 800- frequency converters can be found in figure 3.

2. Speed range

In a frequency converter drive, the actual operating speed of the motor may deviate considerably from its nominal speed (i.e. the speed stamped on the rating plate).

For higher speeds, ensure that the highest permissible rotational speed of the motor or the critical speed of the entire equipment is not exceeded. When high speed operation exceeds the nominal speed of the motor, the following points should be checked:

- Maximum torque of the motor
- Bearing construction
- Lubrication
- Balancing
- Critical speeds
- Shaft seals
- Ventilation
- Fan noise

Guideline values of maximum speeds for M3AA motors within the General purpose motor range are described in figure 1 below. Exact values are available on request.

Figure 1. Guideline values of maximum speeds for General purpose motor in aluminium frame:

Motor size	Speed r/min	
	2-pole	4-pole
M3AA 90-100	6000	6000
M3AA 112-200	4500	4500
M3AA 225-280	3600	3600

At low speed operation the motor's ventilation fan loses its cooling capacity, which causes a higher temperature rise in the motor and in the bearings. A separate constant speed fan can be used to increase cooling capacity and loadability at low speed. It is also important to check the performance of the grease at low speeds.

3. Lubrication

Variable speed operation affects on the bearing temperature, which must be taken into account when selecting the lubrication method and grease type. For example the life time of sealed bearings can be remarkably shorter than in direct on line operation. More information can be found from product specific sections of this catalogue and from ABB's Low Voltage Motors Manual.

4. Insulation protection

Frequency converter supply causes higher voltage stresses at the windings of the motor than the sinusoidal supply. Thus, the insulation system and possible filters must be selected according to the used voltage, cable length and converter type.

When using ABB's low voltage frequency converters, selection criterias mentioned in figure 2 must be followed.

5. Bearing currents

Bearing voltages and currents must be avoided in all motors. Assuming the use of ABB ACS 800 or ACS 550 drive, with uncontrolled DC-voltage, insulated bearings and/or properly dimensioned filters at the converter output must be used according to the instructions in figure 2. (For other alternatives and converter types, please contact ABB.) When ordering, clearly state which alternative will be used.

For more information about bearing currents and voltages, please contact ABB.

6. Cabling, grounding and EMC

The use of a frequency converter puts higher demands on the cabling and grounding of the drive system. The motor must be cabled by using shielded symmetrical cables and cable glands providing 360° bonding (also called EMC-glands). For motors up to 30 kW unsymmetrical cables can be used, but shielded cables are always recommended.

More information about grounding and cabling of a variable speed drive can be found from the manual

“Grounding and cabling of the drive system” (Code: 3AFY 61201998 R0125 REV A) and the ABB’s Low Voltage Motors Manual.

For fulfilling the EMC requirements, special EMC cable(s) must be used in addition to the correct cable gland mounting, with special, extra earthing pieces. Please refer to the manuals of the frequency converter.

Validity

Measures mentioned in Figure 2 apply to the applicable motors within the General motors range (not high-output versions) with ACS 800 and ACS 550 drives with uncontrolled DC-voltage. For other alternatives and converter types, please contact ABB.

Figure 2. Selection rules for insulation and filtering in variable speed drives

	Motor nominal power P_N or frame size		
	$P_N < 100 \text{ kW}$	$P_N \geq 100 \text{ kW}$ or $\geq \text{IEC 315}$	$P_N \geq 350 \text{ kW}$ $\geq \text{IEC 450}$
$U_N \leq 500 \text{ V}$	Standard motor	Standard motor + Insulated N-bearing	Standard motor + Insulated N-bearing + Common mode filter
$U_N \leq 600 \text{ V}$	Standard motor + dU/dt-filter OR Reinforced insulation	Standard motor + dU/dt-filter (reactor) + Insulated N-bearing OR Reinforced insulation + Insulated N-bearing	Standard motor + Insulated N-bearing + dU/dt-filter + Common mode filter OR Reinforced insulation + Insulated N-bearing + Common mode filter
$U_N \leq 690 \text{ V}$	Reinforced insulation + dU/dt-filter	Reinforced insulation + dU/dt-filter (reactor) + Insulated N-bearing	Reinforced insulation + Insulated N-bearing + dU/dt-filter + Common mode filter

dU/dt filter (reactor)

Series reactor. DU/dt -filter decreases the changing rate of the phase and main voltages and thus reduces voltage stresses in the windings. DU/dt -filters also decrease so-called common mode currents and the risk of bearing currents.

Common mode filters

Common mode filters reduce so-called common mode currents in VSD applications and thus decrease the risk of bearing currents. Common mode filters do not significantly affect the phase or main voltages on the motor terminals.

Insulated Bearings

Bearings with insulated inner or outer races are used as the standard solution. So-called hybrid bearings, i.e. bearings with non-conductive ceramic balls, can also be used in special applications. More information for spare part selection is available on request.

Figure 3. Motor loadability with ACS 600 and ACS 800, Field weakening point 50 Hz.

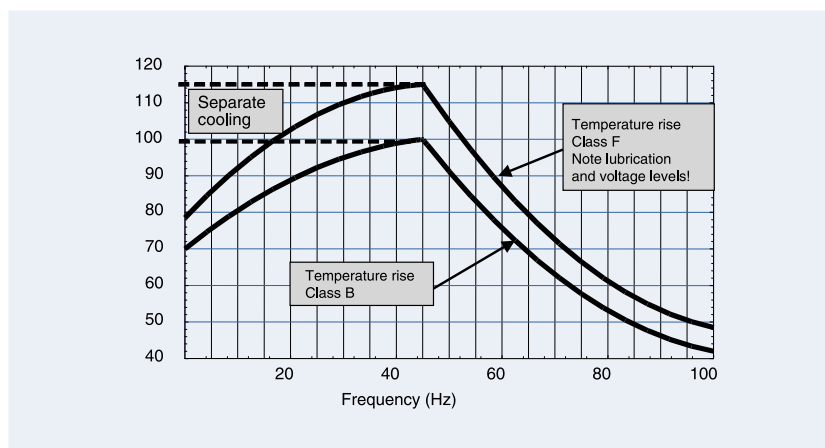

General Purpose Aluminum Motors

Totally enclosed squirrel cage three phase low voltage motors,

Sizes 56 - 280, 0.06 to 95 kW

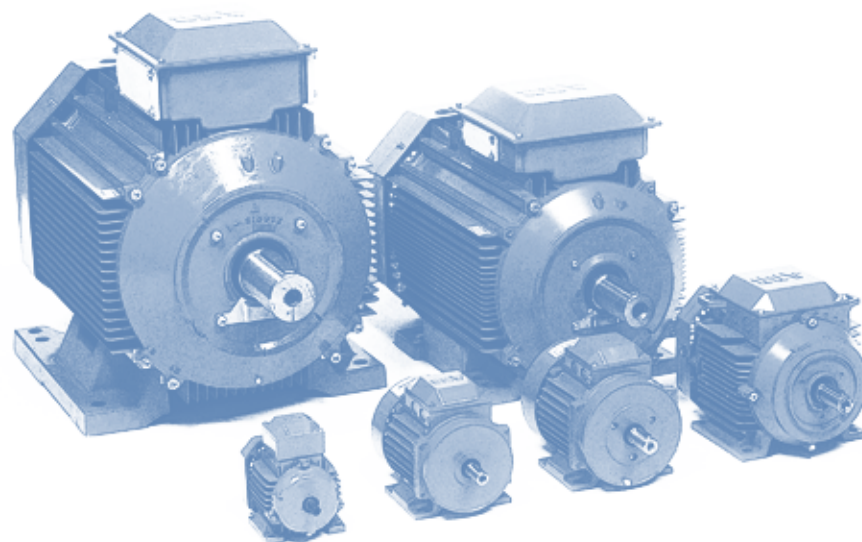

www.abb.com/motor&drives

- > Motors
- > Low voltage motors
- > General purpose motors

Mechanical design.....	12
Rating plates	22
Ordering information.....	23
Technical data.....	24
Variant codes	46
Dimension drawings	53
Accessories	74
Aluminum motors in brief.....	77

Mechanical design

Stator

Stator framework, bearing shields and feet are made of an extra corrosion resistant aluminum alloy with low copper content with the following exceptions:
M2AA 180-250 and M3AA 250 SMA-2 basic version, have cast iron feet.
M3AA 280 has feet and D-end shield of cast iron.

M3AA 250 SMB 2-pole, high output version, as well as M3AA 280 2-pole have cast iron feet and bearing shields.

The flange bearing shields of sizes 180 to 280 are made of cast iron.

Drain holes

Motors that will be operated in very humid or wet environments and especially under intermittent duty should be provided with drain holes. The appropriate IM designation, such as IM 3031, is specified on the basis of the method of mounting the motor.

Motors are provided with closable plastic plugs in the drain holes (see diagram below). The plugs will be open on delivery. When mounting the motors it should be ensured that the drain holes face downwards. In the case of vertical mounting, the upper plug must be hammered home completely. In very dusty environments both

plugs should be hammered home.

Sizes 56 to 63 are supplied as standard with drain holes on D-end while sizes 71 to 280 are supplied with drain holes both on D-end and N-end.

When mounting arrangement differs from foot mounted IM B3, please mention variant code 066 when ordering.

See variant codes 065, 066 and 076 under the heading "Drain holes".

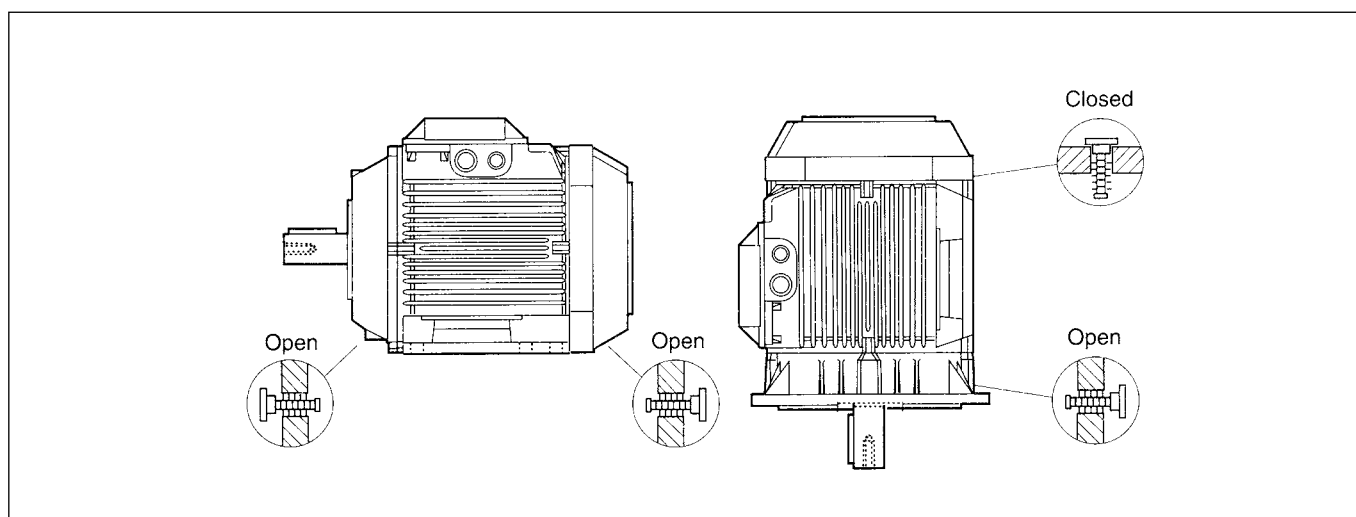

Terminal box

Sizes 56 to 180 and M2AA 200

The terminal box is made of aluminum alloy and is located on top of the stator. The lower part of the box is integrated with the stator. It is provided with 2 knockout openings on each side. Sizes 160-180 also have a third smaller opening. Cable glands are not included.

Sizes 200 to 280, except M2AA 200

The terminal box and cover are made of deep drawn steel and mounted on top of the stator. The box is bolted to the stator and is not rotatable. The size of the box is the same for all motors.

In the basic design the terminal box is provided with two FL 13 flange openings, one on each side. The opening on the right side, seen from the D-end, is supplied with a flange with two holes for M40 cable glands. On delivery the holes are sealed by means of plastic plugs. Cable glands are not supplied. The opening on the

other side is provided with a cover flange.

The motors can also be provided with an extra large terminal box, standard for voltage code S and frame size 280. See variant code 019 under the heading "Terminal box". This will increase the dimension HD by 32 mm. The box is supplied with two FL 21 openings. The right opening is provided with a flange with two holes for M63 cable glands. The holes are sealed by means of plastic plugs. Cable glands are not supplied. The opening on the other side is provided with a cover flange. The box can also be provided with an FL 13 opening towards the N-end.

When new motors are manufactured the terminal box can be mounted on the left or the right side. See variant codes 021 and 180 under the heading "Terminal box".

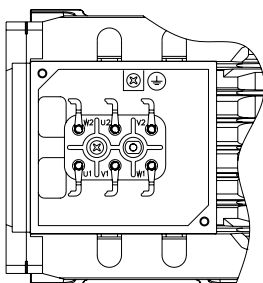

Terminal box size 56-80.

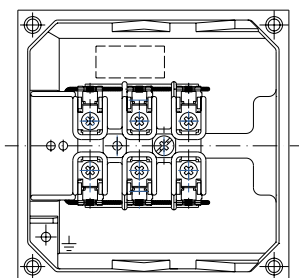

Terminal box size 90-100.

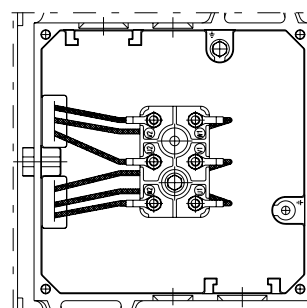

Terminal box size 112-132.

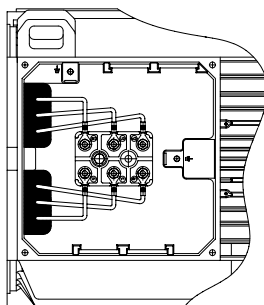

Terminal box size 160-180 and M2AA 200.

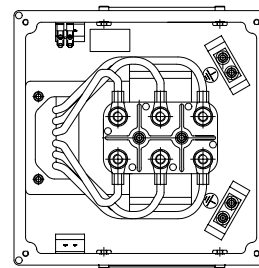

Terminal box size 200-280, except M2AA 200.

Connections

The terminal block is provided with 6 terminals for connecting Cu-cable. The terminals are marked in accordance with IEC 60034-8.

Connection openings

Motor size	Opening	Metric cable entry	Method of connection	Terminal bolt size	Maximum connectable Cu-cable area, mm ²
56-63	Knock-out opening	1 x M16 x 1.5 1 x Pg 11	Screw terminal	M4	2.5
71-80	Knock-out opening	2 x M20 x 1.5 2 x Pg 16	Screw terminal	M4	4
90-100	Knock-out opening	2 x (M25 + M20)	Screw terminal	M4	6
112-132	Knock-out opening	2 x (M25 + M20)	Cable lug	M5	10
160-180	Knock-out opening	2 x (2 x M40 + M16)	Cable lug	M6	35
200 ¹⁾	Knock-out opening	2 x (2 x M40 + M16)	Cable lug	M6	35
200-250 ²⁾	2 x FL 13	1 x (2 x M40 + M16)	Cable lug	M10	70
280	2 x FL 21	1 x (2 x M63 + M16)	Cable lug	M10	70

¹⁾ M2AA

²⁾ M2AA 200 excluded

Bearings

The motors are provided with bearings according to the tables below.

Greater axial forces can be tolerated if the motors are provided with angular contact ball bearings. Note that

in such cases the axial force must only operate in one direction.

Motor versions with roller bearings tolerate greater radial forces.

Basic version with deep groove ball bearings

Basic design motors			
Motor size		Foot- and flange-mounted motor	
		D-end	N-end
56		6201-2Z/C3	6201-2Z/C3
63		6202-2Z/C3	6201-2Z/C3
71		6203-2Z/C3	6202-2Z/C3
80		6204-2Z/C3	6203-2Z/C3
90		6205-2Z/C3	6204-2Z/C3
100		6306-2Z/C3	6205-2Z/C3
112 ²⁾	short	6206-2Z/C3	6205-2Z/C3
112 ²⁾	long	6206-2Z/C3	6206-2Z/C3
132 ²⁾	short	6208-2Z/C3	6206-2Z/C3
132 ²⁾	long	6208-2Z/C3	6208-2Z/C3
160		6309-2Z/C3	6209-2Z/C3
180		6310-2Z/C3	6209-2Z/C3
200 ¹⁾		6312-2Z/C3	6209-2Z/C3
200		6312/C3	6210/C3
225 ¹⁾		6313/C3	6210/C3
225		6313/C3	6212/C3
250 ¹⁾		6315/C3	6212/C3
250		6315/C3	6213/C3
280	2-pole	6315/C3	6213/C3
280	4-8 pole	6316/C3	6213/C3

¹⁾ M2AA

²⁾ short: M2AA 112: M-2,M-4; M2AA 132: SA-2, SB-2, S-4, M-4
M3AA 112: M-6, M-8; M3AA 132: SA-2, S-4, S-6, MA-6, MB-6, S-8, M-8, S-two-speed

long: remaining versions

Alternative designs:

Version with roller bearings

It is recommended to use roller bearings in belt drives for motor sizes 160 - 280.

See variant code 037 under the heading "Bearings and lubrication".

Motor size		D-end	N-end
90		NU 205	–
100		NU 306	–
160		NU 309 ECP	–
180		NU 310 ECP	–
200		NU 312 ECP	–
225		NU 313 ECP	–
250		NU 315 ECP	–
280	2-pole	NU 315 ECP	–
280	4-8 pole	NU 316 ECP	–

Version with angular contact ball bearings

See variant codes 058 and 059 under the heading "Bearings and lubrication".

Motor size		D-end	N-end
		058	059
90		7205 B	7204 B
100		7306 B	7205 B
112 ²⁾	short	7206 BE	7205 BE
112 ²⁾	long	7206 BE	7206 BE
132 ²⁾	short	7208 BE	7206 BE
132 ²⁾	long	7208 BE	7208 BE
160 ¹⁾		7309 BE	7209 BE
180 ¹⁾		7310 BE	7209 BE
200 ¹⁾		7312 BE	7210 BE
225 ¹⁾		7313 BE	7212 BE
250 ¹⁾		7315 BE	7213 BE
280	2-pole	7315 BE	7213 BE
280	4-8 pole	7316 BE	7213 BE

¹⁾ M2AA on request

²⁾ short: M2AA 112: M-2,M-4; M2AA 132: SA-2, SB-2, S-4, M-4
M3AA 112: M-6, M-8; M3AA 132: SA-2, S-4, S-6, MA-6, MB-6, S-8, M-8, S-two-speed

long: remaining versions

Transport locking

Motors provided with roller bearings or angular contact ball bearings are fitted with a transport lock to prevent damage to the bearings, due to vibration, during transport.

Axially-locked bearings

The table below shows which of the motor's bearings are axially locked in the bearing seat. In motor sizes 56 to 80 the locking is done by an inner bearing circlip, in motor sizes 90 to 280 by an inner bearing cover.

See also variant code 042 under the heading "Bearings and lubrication".

Motor size	Foot-mounted motors	Flange-mounted motors	
		Large flange	Small flange
56-63	On request at D-end	On request at D-end	On request at D-end
71-80	On request at D-end	D-end	On request at D-end
90-100	D-end ¹⁾	D-end ¹⁾	D-end ¹⁾
112-132	D-end ¹⁾	D-end	D-end
160-280	D-end	D-end	–

¹⁾ A spring-washer at the N-end presses the rotor toward the D-end.

Lubrication

The motors are delivered with bearing grease for use at normal temperatures in dry or humid environments. The motors are lubricated for ambient temperatures 40°C and in some cases even above 40°C, see table 1 next page.

Motor sizes 63-180 and M2AA 200 are provided with shielded bearings. On request, motor sizes 90 to 180 and M2AA 200 are provided with grease nipples for regreasing, see variant code 041 under the heading "Bearings and lubrications".

Motor sizes 200-280, except M2AA 200, are provided with grease nipples for re-greasing as standard.

The lubrication interval L_1 , suitable for relubricated bearings, is defined as the number of operating hours after which 99 per cent of the bearings are adequately lubricated.

Lubrication intervals and grease quantities are specified on a plate on the motor as well as in the manual supplied with the motor.

The grease lifetime L_{10} , suitable for permanent lubricated bearings, is defined as the number of operating hours after which 90 per cent of the bearings are adequately lubricated. 50 per cent of the bearings achieve two times this figure. Maximum lifetime, however, should be regarded as 40000 hours.

In case of high ambient temperatures the shaft loads must be reduced compared to permissible loadings in the table (see pages 18 to 21), please contact ABB.

Table 1: Grease lifetime L_{10} in deep groove ball bearings of type 2Z in horizontally mounted motors in continuous running duty.

Motor	r/min	Ambient temperature and rated output													
		25 °C		40 °C		50 °C		60 °C		70 °C		80 °C			
		Basic	High	Basic	High	Basic	High	Basic	High	Basic	High	Basic	High		
56-63	3000	40000	40000	40000	40000	40000	40000	40000	40000	40000	40000	40000	40000	27000	
	1500														32000
	1000														
	750														
71	3000	40000	40000	40000	40000	40000	40000	40000	40000	40000	40000	40000	40000	27000	
	1500														32000
	1000														
	750														
80	3000	40000	40000	40000	40000	40000	40000	40000	40000	40000	40000	40000	40000	27000	
	1500														32000
	1000														
	750														
90	3000	40000	40000	40000	40000	40000	40000	40000	40000	40000	40000	40000	40000	27000	
	1500														32000
	1000														
	750														
100	3000	40000	40000	40000	40000	40000	40000	40000	40000	40000	40000	40000	40000	27000	
	1500														32000
	1000														
	750														
112	3000	40000	40000	40000	40000	40000	40000	40000	40000	40000	40000	40000	40000	27000	
	1500														32000
	1000														
	750														
132	3000	40000	40000	40000	40000	40000	40000	40000	40000	40000	40000	40000	40000	27000	
	1500														32000
	1000														
	750														
160	3000	40000	40000	40000	40000	40000	40000	40000	40000	40000	40000	40000	40000	27000	
	1500														32000
	1000														
	750														
180	3000	40000	40000	40000	40000	40000	40000	40000	40000	40000	40000	40000	40000	27000	
	1500														32000
	1000														
	750														
M2AA	3000	27000		27000		20000		11000							
200	1500	40000		38000		38000		22000							

In vertically mounted motors, the grease lifetime is half the figures above.
 For applications corresponding to the empty cells in the table, please contact ABB. These applications can imply reduced lifetime for bearings and winding.
 Motors with roller bearings (optional) have considerably shorter grease life. For continuous operation regreasing nipples should be considered.

Lubrication intervals

ABB follows the L1-principle in defining lubrication interval. That means that 99% of the motors are sure to make the interval time. The lubrication intervals can also be calculated according to the L10-principle, which are normally dou-

bled compared to L1-values. Values available from ABB at request.

The table below gives lubrication intervals according to the L1-principle for different speeds. The values are valid for horizontal mounted mo-

tors (B3), with about 80°C bearing temperature and using good quality grease with lithium complex soap and with mineral or PAO-oil.

For more information, see ABB's Low Voltage Motors Manual.

Frame size	Amount of grease g	3600 r/min	3000 r/min	1800 r/min	1500 r/min	1000 r/min	500-750 r/min
Ball bearings: lubrication intervals in duty hours							
180	30	6000	8000	13500	16000	20000	23000
200	40	4000	6000	11000	13000	17000	21000
225	50	3000	5000	10000	12500	16500	20000
250	60	2500	4000	9000	11500	15000	18000
280	35	2000	3500	-	-	-	-
280	70	-	-	8000	10500	14000	17000

Frame size	Amount of grease g	3600 r/min	3000 r/min	1800 r/min	1500 r/min	1000 r/min	500-750 r/min
Roller bearings: lubrication intervals in duty hours							
180	30	3000	4000	7000	8000	10000	11500
200	40	2000	3000	5500	6500	8500	10500
225	50	1500	2500	5000	6000	8000	10000
250	60	1300	2200	4500	5700	7500	9000
280	35	1000	1800	-	-	-	-
280	70	-	-	4000	5300	7000	8500

Permissible loading on shaft

Pulley diameter

When the desired bearing life has been determined the minimum permissible pulley diameter can be calculated with F_R , according to the formula:

$$D = \frac{1.9 \cdot 10^7 \cdot K \cdot P}{n \cdot F_R}$$

Bearing life

The nominal life is defined as the number of hours that are attained or exceeded by 90% of identical bearings, in a large test series, under certain specified conditions. 50% of the bearings attain a life of as much as 5 times this figure.

The life of bearings is dependent on various factors such as bearing load, motor speed, operating temperature and the purity of the grease. The permissible radial and axial loading for different motor sizes is shown in the table on the following pages.

The table is valid for 50 Hz. For 60 Hz and/or some other bearing life than specified in the table the values are changed according to the table on the right.

Permissible radial forces

The table at right shows the permissible radial force in Newton assuming zero axial force.

Permissible loads of simultaneous radial and axial forces will be supplied on request.

The bearing life, L_{10} , is calculated according to SKF's theory on bearing life $L_{10_{aah}}$, which also takes the purity of the grease into consideration. An adequate lubrication is a necessary prerequisite for the table at right.

If the radial force is applied between points X_0 and X_{max} , the permissible force F_R can be calculated from the following formula:

$$F_R = F_{X_0} - \frac{X}{E} (F_{X_0} - F_{X_{max}})$$

E = length of shaft extension in basic version.

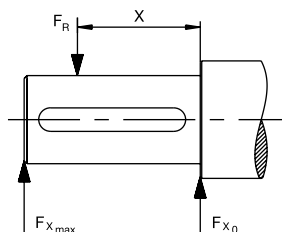

where:

- D = diameter of pulley, mm
- P = power requirement, kW
- n = motor speed, r/min.
- K = belt tension factor, dependent on belt type and type of duty. A common value for V-belts is $K = 2.5$
- F_R = permissible radial force according to the tables

The table values assume the occurrence of only radial or axial forces. In the case of simultaneous radial and axial forces information can be supplied on request. It is assumed that the radial force is applied at the end of the motor shaft.

Permissible force at changed bearing life or supply frequency

Bearing life in hours at		Permissible force, as percentage of value in tables
50 Hz	60 Hz	
25,000	21,000	100% of value for 25,000 hours
40,000	33,000	100% of value for 40,000 hours
63,000	52,000	86% of value for 40,000 hours
80,000	67,000	80% of value for 40,000 hours

Motor size	No. of poles	Length of shaft extension E (mm)	Ball bearings			
			Basic design with deep groove ball bearings			
			25,000 hrs		40,000 hrs	
F_{X_0} (N)	$F_{X_{max}}$ (N)	F_{X_0} (N)	$F_{X_{max}}$ (N)			
56	2	20	240	200	260	200
	4	20	300	200	280	200
	6	20	340	280	340	280
	8	20	340	280	340	280
63	2	23	490	400	490	400
	4	23	490	400	490	400
	8	23	490	400	490	400
71	2	30	680	570	680	570
	4	30	680	570	680	570
	6	30	680	570	680	570
	8	30	680	570	680	570
80	2	40	630	750	930	750
	4	40	930	750	930	750
	6	40	930	750	930	750
	8	40	930	750	930	750
90	2	50	1010	810	1010	810
	4	50	1010	810	1010	810
	6	50	1010	810	1010	810
	8	50	1010	810	1010	810
100 ¹⁾	2	60	2280	1800	2280	1800
	4	60	2280	1800	2280	1800
	6	60	2280	1800	2280	1800
	8	60	2280	1800	2280	1800

¹⁾ Basic design with 63-series bearings at the D-end.

Permissible radial forces

Motor sizes 112 to 180

Motor size	No. of poles	Length of shaft extension E (mm)	Ball bearings								Roller bearings			
			Basic design with deep groove ball bearings				Alternative design with 63-series bearings				Alternative design with roller bearings			
			25,000 hrs		40,000 hrs		25,000 hrs		40,000 hrs		25,000 hrs		40,000 hrs	
FX_0 (N)	FX_{max} (N)	FX_0 (N)	FX_{max} (N)	FX_0 (N)	FX_{max} (N)	FX_0 (N)	FX_{max} (N)	FX_0 (N)	FX_{max} (N)	FX_0 (N)	FX_{max} (N)	FX_0 (N)	FX_{max} (N)	
112 M	2	60	1800	1420	1620	1280	2160	1700	2160	1700				
	4	60	1790	1410	1590	1250	2160	1700	2160	1700				
	6	60	1910	1510	1700	1340	2160	1700	2160	1700				
	8	60	1940	1530	1720	1360	2160	1700	2160	1700				
112 MB	2	60	1820	1470	1640	1330	2100	1700	2100	1700				
	4	60	1770	1430	1560	1260	2100	1700	2100	1700				
	6	60	1880	1520	1650	1340	2100	1700	2100	1700				
	8	60	1930	1560	1690	1370	2100	1700	2100	1700				
132 SA	2	80	3020	2360	2740	2140	4070	3180	3670	2870				
132 SB	2	80	3020	2360	2730	2130	4060	3170	3670	2870				
132 SC	2	80	3030	2430	2750	2200	3990	3200	3690	2960				
132 S	4	80	3120	2440	2790	2180	4090	3200	3830	2990				
132 M	4	80	3080	2410	2750	2150	4100	3200	3780	2950				
132 MB	4	80	3050	2440	2710	2170	3990	3200	3740	3000				
132 S	6	80	3280	2560	2910	2270	4100	3200	3990	3120				
132 MA	6	80	3240	2530	2880	2250	4100	3200	3970	3100				
132 MB	6	80	3200	2500	2840	2220	4100	3200	3930	3070				
132 MC	6	80	3010	2510	2660	2220	3840	3200	3700	3090				
132 S	8	80	3370	2630	2980	2330	4100	3200	4100	3200				
132 M	8	80	3310	2590	2940	2300	4100	3200	4060	3170				
132 MB	8	80	3280	2630	2910	2330	3990	3200	3990	3200				
160 MA	2	110	4470	3500	4470	3500					4470	3500	4470	3500
	8	110	4470	3500	4470	3500					4470	3500	4470	3500
160 M	2	110	4470	3500	4470	3500					4470	3500	4470	3500
	4	110	4470	3500	4470	3500					4470	3500	4470	3500
	6	110	4470	3500	4470	3500					4470	3500	4470	3500
	8	110	4470	3500	4470	3500					4470	3500	4470	3500
	8	110	4470	3500	4470	3500					4470	3500	4470	3500
160 L	2	110	4470	3500	4470	3500					4470	3500	4470	3500
	4	110	4470	3500	4470	3500					4470	3500	4470	3500
	6	110	4470	3500	4470	3500					4470	3500	4470	3500
	8	110	4380	3500	4380	3500					4380	3500	4380	3500
160 LB	2	110	4470	3500	4470	3500					4470	3500	4470	3500
	4	110	4470	3500	4470	3500					4470	3500	4470	3500
	6	110	4380	3500	4380	3500					4380	3500	4380	3500
	8	110	4380	3500	4380	3500					4380	3500	4380	3500
180 M	2	110	6900	5550	6360	5110					7338	5900	7340	5900
	4	110	7100	5710	6470	5200					7338	5900	7340	5900

Permissible radial forces
Motor sizes 180 to 280

Motor size	No. of poles	Length of shaft extension E (mm)	Ball bearings				Roller bearings			
			Basic design with deep groove ball bearings				Alternative design with roller bearings			
			25,000 hrs		40,000 hrs		25,000 hrs		40,000 hrs	
		FX ₀ (N)	FX _{max} (N)	FX ₀ (N)	FX _{max} (N)	FX ₀ (N)	FX _{max} (N)	FX ₀ (N)	FX _{max} (N)	
180 L	4	110	7050	5670	6410	5150	7340	5900	7340	5900
	6	110	7340	5900	6840	5500	7340	5900	7340	5900
	8	110	7340	5900	6930	5570	7340	5900	7340	5900
180 LB	2	110	6900	5550	6360	5110	7340	5900	7340	5900
	4	110	6990	5670	6350	5150	7280	5900	7280	5900
	6	110	7280	5900	6780	5500	7280	5900	7280	5900
	8	110	7280	5900	6870	5570	7280	5900	7280	5900
M2AA 200	2	110	7000	5800	6300	5200	9100	7500	8100	6700
	4	110	6700	5500	5900	4900	9500	7800	8600	7100
M3AA 200 MLA	2	110	4940	4070	4370	3600	9460	7790	9460	7790
	4	110	5360	4410	4690	3860	9460	7790	9460	7790
	6	110	5590	4600	4850	3990	9460	7790	9460	7790
	8	110	5680	4680	4910	4040	9460	7790	9460	7790
M3AA 200 MLB	2	110	4930	4060	4360	3590	9460	7790	9460	7790
	4	110	5290	4360	4630	3810	9460	7790	9460	7790
	6	110	5510	4540	4780	3940	9460	7790	9460	7790
	8	110	5670	4670	4890	4030	9460	7790	9460	7790
M3AA 200 MLC	2	110	4920	4050	4360	3590	9460	7790	9460	7790
	6	110	5380	4430	4640	3820	9460	7790	9460	7790
225 SMA	4	140	5830	4930	5100	4320	9810	8300	9810	8300
	8	140	6400	5420	5550	4700	9810	8300	9810	8300
225 SMB	2	110	5400	4530	4780	4010	10600	8900	10600	8900
	4	140	5750	4870	5030	4260	9810	8300	9810	8300
	6	140	6000	5080	5200	4400	9810	8300	9810	8300
	8	140	6320	5350	5470	4630	9810	8300	9810	8300
225 SMC	2	110	5370	4510	4750	3990	10600	8900	10600	8900
	4	140	5720	4840	5000	4230	9810	8300	9810	8300
	6	140	5930	5020	5130	4340	9810	8300	9810	8300
	8	140	6180	5230	5320	4500	9810	8300	9810	8300
250 SMA	2	140	6970	5620	6180	4980	11290	9100	11290	9100
	4	140	7693	6200	6750	5440	14330	11550	14330	11550
	6	140	7978	6430	6940	5590	14330	11550	14330	11550
	8	140	8250	6650	7150	5760	14330	11500	14330	11550
250 SMB	2	140	6960	5610	6150	4960	11290	9100	11290	9100
	4	140	7620	6140	6680	5380	14330	11550	14330	11550
	6	140	7940	6400	6900	5560	14330	11550	14330	11550
	8	140	8180	6590	7070	5700	14330	11550	14330	11550
280 SMA	2	140	6650	5400	5850	4750	15260	12400	13790	11200
	4	140	7750	6300	6890	5600	18460	15000	16560	13450
	6	140	8810	7100	7760	6250	21090	17000	18860	15200
	8	140	9000	7250	7880	6350	21840	17600	19360	15600
280 SMB	2	140	6460	5250	5720	4650	15260	12400	13790	11200
	4	140	7510	6100	6590	5350	17850	14500	16060	13050



Permissible axial forces

The following tables give the permissible axial forces in Newton, assuming zero radial force. The values are based on normal conditions at 50 Hz with standard bearings and calculated bearing lives of 20,000 and 40,000 hours.

At 60 Hz the values are to be reduced by 10%.

For two-speed motors, the values are to be based on the higher speed. The permissible loads of simultaneous radial and axial forces will be supplied on request.

Given axial forces F_{AD} , assumes D-bearing locked by means of locking ring.

Mounting arrangement IM B3

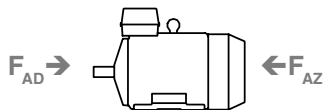

Motor size	20,000 hours								40,000 hours							
	2-pole		4-pole		6-pole		8-pole		2-pole		4-pole		6-pole		8-pole	
	F_{AD} N	F_{AZ} N	F_{AD} N	F_{AZ} N	F_{AD} N	F_{AZ} N	F_{AD} N	F_{AZ} N	F_{AD} N	F_{AZ} N	F_{AD} N	F_{AZ} N	F_{AD} N	F_{AZ} N	F_{AD} N	F_{AZ} N
56	470	230	520	280	540	300	540	300	430	190	470	230	480	240	480	240
63	790	390	865	465	-	-	895	495	720	320	780	380	-	-	895	495
71	985	485	1070	570	1135	635	1130	630	900	400	970	470	1020	520	1015	515
80	1305	705	1420	820	1505	905	1540	940	1185	585	1285	685	1350	750	1375	775
90	1360	930	1490	1070	1590	1165	1635	1210	1225	800	1335	915	1415	990	1450	1025
100	2805	1945	3075	2215	3260	2400	3355	2495	2540	1680	2760	1900	2910	2050	2985	2125
112 M	1500	1500	1600	1600	1730	1730	1750	1750	1320	1320	1390	1390	1500	1500	1510	1510
112 MB	1530	1530	1600	1600	1720	1720	1760	1760	1340	1340	1390	1390	1490	1490	1520	1520
132 SA	2570	2570	-	-	-	-	-	-	2260	2260	-	-	-	-	-	-
132 SB	2570	2570	-	-	-	-	-	-	2260	2260	-	-	-	-	-	-
132 SC	2520	2520	-	-	-	-	-	-	2210	2210	-	-	-	-	-	-
132 S	-	-	2770	2770	2950	2950	3040	3040	-	-	2440	2440	2580	2580	2650	2650
132 M	-	-	2750	2750	-	-	3020	3020	-	-	2420	2420	-	-	2630	2630
132 MA	-	-	-	-	2940	2940	-	-	-	-	-	-	2570	2570	-	-
132 MB	-	-	2680	2680	2910	2910	2940	2940	-	-	2340	2340	2550	2550	2560	2560
132 MC	-	-	-	-	2830	2830	-	-	-	-	-	-	2460	2460	-	-
160 MA	4730	4730	-	-	-	-	5240	5240	4220	4220	-	-	-	-	4640	4640
160 M	4730	4730	5230	5230	5220	5220	5220	5220	4220	4220	4640	4640	4630	4630	4630	4630
160 L	5240	5240	5220	5220	5050	5050	4720	4720	4650	4650	4630	4630	4470	4470	4740	4740
160 LB	4240	4240	5050	5050	4720	4720	4720	4720	4650	4650	4470	4470	4740	4740	4740	4740
180 M	4660	4660	4950	4950	-	-	-	-	4250	4250	4500	4500	-	-	-	-
180 L	-	-	4870	4870	5200	5200	5370	5370	-	-	4390	4390	4710	4710	4850	4850
180 LB	4660	4660	4870	4870	5200	5200	5370	5370	4250	4250	4390	4390	4710	4710	4850	4850
200 MLA	3050	3050	3850	3850	4400	4400	4850	4850	2430	2430	3050	3050	3500	3500	3850	3850
200 MLB	3050	3050	3850	3850	4400	4400	4850	4850	2430	2430	3050	3050	3500	3500	3850	3850
200 MLC	3050	3050	-	-	4400	4400	-	-	2430	2430	-	-	3500	3500	-	-
225 SMA	-	-	4340	4340	-	-	5460	5460	-	-	3440	3440	-	-	4340	4340
225 SMB	3440	3440	4340	4340	4960	4960	5460	5460	2730	2730	3440	3440	3940	3940	4340	4340
225 SMC	3440	3440	4340	4340	4960	4960	5460	5460	2730	2730	3440	3440	3940	3940	4340	4340
250 SMA	4180	4180	5260	5260	6020	6020	6630	6630	3320	3320	4180	4180	4780	4780	5260	5260
250 SMB	4180	4180	5260	5260	6020	6020	6630	6630	3320	3320	4180	4180	4780	4780	5260	5260
280 SMA	5000	5000	6200	6200	7100	7100	7350	7350	4500	4500	5400	5400	6250	6250	6500	6500
280 SMB	5000	5000	6100	6100	-	-	-	-	4400	4400	5300	5300	-	-	-	-

Permissible axial forces

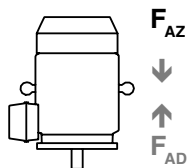

Mounting arrangement IM V1

Motor size	20,000 hours								40,000 hours							
	2-pole		4-pole		6-pole		8-pole		2-pole		4-pole		6-pole		8-pole	
	F _{AD} N	F _{AZ} N	F _{AD} N	F _{AZ} N	F _{AD} N	F _{AZ} N	F _{AD} N	F _{AZ} N	F _{AD} N	F _{AZ} N	F _{AD} N	F _{AZ} N	F _{AD} N	F _{AZ} N	F _{AD} N	F _{AZ} N
56	470	230	520	270	540	290	540	290	430	190	470	230	480	240	480	240
63	790	380	875	455	-	-	905	485	725	310	790	370	-	-	810	390
71	998	470	1085	555	1150	620	1145	615	910	385	985	455	1035	505	1030	500
80	1320	685	1445	790	1530	880	1565	915	1200	565	1310	655	1375	725	1400	750
90	1390	900	1525	1035	1625	1130	1670	1180	1255	770	1370	880	1450	955	1485	990
100	2855	1890	3135	2155	3320	2340	3420	2425	2590	1625	2820	1840	2970	1990	3050	2060
112 M	2290	2170	2490	2330	2680	2510	2770	2590	2030	1910	2190	2030	2350	2180	2410	2230
112 MB	2340	2170	2520	2300	2700	2480	2790	2570	2080	1910	2220	2000	2360	2140	2430	2210
132 SA	3550	3370	-	-	-	-	-	-	3160	2980	-	-	-	-	-	-
132 SB	3560	3360	-	-	-	-	-	-	3170	2970	-	-	-	-	-	-
132 SC	3550	3270	-	-	-	-	-	-	3160	2880	-	-	-	-	-	-
132 S	-	-	3910	3630	4160	3880	4320	3990	-	-	3460	3180	3660	3380	3780	3450
132 M	-	-	3910	3590	-	-	4330	3930	-	-	3450	3130	-	-	3790	3390
132 MA	-	-	-	-	4180	3850	-	-	-	-	-	-	3670	3340	-	-
132 MB	-	-	3880	3460	4180	3780	4260	3840	-	-	3430	3010	3680	3280	3730	3310
132 MC	-	-	-	-	4110	3690	-	-	-	-	-	-	3610	3190	-	-
160 MA	4940	4520	-	-	-	-	5520	4960	4430	4010	-	-	-	-	4920	4360
160 M	4960	4500	5500	4960	5540	4900	5540	4900	4450	3990	4910	4370	4950	4310	4950	4310
160 L	5520	4960	5560	4880	5420	4680	5170	4280	4930	4370	4970	4290	4840	4100	5190	4300
160 LB	5540	4940	5420	4680	5170	4280	5170	4280	4950	4350	4840	4100	5190	4300	5190	4300
180 M	4990	4330	5400	4500	-	-	-	-	4580	3920	4950	4050	-	-	-	-
180 L	-	-	5390	4350	5770	4630	5930	4810	-	-	4910	3870	5280	4140	5410	4290
180 LB	5040	4280	5470	4270	5810	4590	5980	4760	4630	3870	4990	3790	5320	4100	5460	4240
200 MLA	3600	2500	4580	3120	5280	3530	5720	3980	2970	1870	3780	2320	4370	2620	4720	2980
200 MLB	3600	2500	4580	3120	5280	3530	5720	3980	2970	1870	3780	2320	4370	2620	4720	2980
200 MLC	3600	2500	-	-	5280	3530	-	-	2970	1870	-	-	4370	2620	-	-
225 SMA	-	-	5230	3440	-	-	6530	4400	-	-	4330	2550	-	-	5400	3270
225 SMB	4140	2740	5230	3440	6030	3900	6530	4400	3430	2030	4330	2550	5010	2870	5400	3270
225 SMC	4140	2740	5230	3440	6030	3900	6530	4400	3430	2030	4330	2550	5010	2870	5400	3270
250 SMA	5020	3330	6380	4150	7440	4610	8050	5210	4160	2470	5290	3060	6200	3360	6680	3840
250 SMB	5020	3330	6380	4150	7440	4610	8050	5210	4160	2470	5290	3060	6200	3360	6680	3840
280 SMA	5950	4050	7380	5010	8540	5660	8810	5890	5450	3550	6580	4210	7690	4810	7960	5040
280 SMB	5950	4050	7380	5010	-	-	-	-	5450	3550	6580	4210	-	-	-	-

2

Rating plates

Single-speed motors of size 56 to 132 are stamped with 50 and 60 Hz at voltage code S and D. The current rating for each voltage range is specified on the rating plate. It represents the highest current that can exist within the voltage range at the rated output. The power factor and speed specified on the rating plate apply at 400 V 50 Hz and 460 V 60 Hz.

Single-speed motors of size 160 to 280 are stamped with 50 and 60 Hz at voltage code S and D. The rating plate is arranged in the form of a table with values for current, power factor and motor speed at six voltages.

Motor sizes 56 to 71

ABB Motors		CE	
Cl.F IP55 IEC 34			
Motor 3~ M2VA71B-4			
○ 3GVA072002-ASA ○			
43/2002		cos φ 0.69/0.74	
1.1 AY 1.9 AΔ		Hz r/min kW	
V380-420Y/220-240 Δ		50	1420 0.37
V440-480Y/250-280 Δ		60	1700 0.45

Motor sizes 80

ABB Motors		CE	
Motor 3~ CL. F IP55 IEC 34-1			
○ M2VA80B-4 ○		3GVA082002-ASA	
43/2002		Hz	r/min kW A cos φ
V 380-420 Y 220-240 Δ		50	1410 0.75 2.0/3.5 0.74
V 440-480 Y 250-280 Δ		60	1690 0.90 1.9/3.3 0.77

Motor sizes 90 to 100

ABB Motors		EFF 2 CE	
3-Motor M2AA 090 L-4		CL.F IP 55 IEC 60034-1	
3GAA092002-ADE			
N°.			
V	Hz	r/min	kW A Cos φ
660-690 Y	50	1420	1,50 2,00 0,79
380-420 D	50	1420	1,50 3,50 0,79
440-480 D	60	1710	1,75 3,50 0,79
IM1001			
6205-2Z/C3		6204-2Z/C3 16 kg	

Motor sizes 112 to 132

ABB		EFF 1 CE	
3~Motor M3AA 132M		CL.F IP 55 IEC 60034-1	
3G AA 132024-ADC			
No.			
V	Hz	r/min	kW A cos φ
660-690 Y	50	1450	7,5 8,4 0,87
380-420 Δ	50	1450	7,5 14,6 0,87
440-480 Δ	60	1750	8,6 14,3 0,87
6208-2Z/C3 6208-2Z/C3 59 kg			

Motor sizes 160 to 280

ABB		EFF 1 CE	
3 Motor M3AA 160 L 4		IEC 160 M/L 42	
No			
Ins.cl. F		IP 55	
V	Hz	kW r/min	A cos φ I _a /I _N t _e /s
690 Y	50	15 1460	16.7 0.82
400 Δ	50	15 1460	29 0.82
660 Y	50	15 1455	17.3 0.84
380 Δ	50	15 1455	30 0.84
415 Δ	50	15 1465	28 0.81
440 Δ	60	18 1750	30 0.84
Prod.code 3GAA 162 102-ADC			
6309-2Z/C3		6209-2Z/C3 103 kg	
3GV 193 014-11		IEC 60034-1	

Ordering information

When placing an order, please state the following minimum data in the order, as in the example.

The product code of the motor is composed in accordance with the following example.

Motor type	M3AA 112 MB
Pole number	4
Mounting arrangement (IM-code)	IM B3 (IM 1001)
Rated output	5.5 kW
Product code	3GAA 112002-ACD
Variant codes if needed	

Motor size

A	B	C	D, E, F															
M3AA	112 MB	3GAA 112 002 -	ADC, 122, 043, etc.															
		<table border="1"> <tr> <td>1</td><td>2</td><td>3</td><td>4</td><td>5</td><td>6</td><td>7</td><td>8</td><td>9</td><td>10</td><td>11</td><td>12</td><td>13</td><td>14...</td> </tr> </table>	1	2	3	4	5	6	7	8	9	10	11	12	13	14...		
1	2	3	4	5	6	7	8	9	10	11	12	13	14...					
				<p>A Motor type B Motor size C Product code D Code for mounting arrangement E Voltage and frequency code F Generation code followed by variant codes</p>														

Explanation of the product code

Positions 1 to 4

3GAA/3GVA =

Totally enclosed motor with aluminum stator frame

Position 4

Type of rotor

A = Squirrel cage rotor

Positions 5 and 6

IEC size

05 = 56	13 = 132
06 = 63	16 = 160
07 = 71	18 = 180
08 = 80	20 = 200
09 = 90	22 = 225
10 = 100	25 = 250
11 = 112	28 = 280

Position 7

Pole pairs

1 = 2 poles
2 = 4 poles
3 = 6 poles
4 = 8 poles
5 = 10 poles
6 = 12 poles
7 = > 12 poles
8 = Two-speed motors
9 = Multi-speed motors

Positions 8 to 10

Running number

Position 11

- (dash)

Position 12

Mounting arrangement

A = Foot-mounted motor
B = Flange-mounted motor. Large flange with clearance holes.
C = Flange-mounted motor. Small flange with tapped holes.
F = Foot- and flange-mounted motor. Special flange.
H = Foot- and flange-mounted motor. Large flange with clearance holes.
J = Foot- and flange-mounted motor. Small flange with tapped holes.
N = Flange-mounted (CI ring flange FF)
P = Foot- and flange-mounted motor (CI ring flange FF)
V = Flange-mounted motor. Special flange.

Position 13

Voltage and frequency: See tables below

Position 14

Version A,B,C... =

Generation code followed by variant codes

Code letters for supplementing the product code - single speed motors

Motor size	Code letter for voltage and frequency Direct start or, with Δ-connection, also Y/Δ-start									
	S		D		H	E	F	T	U	X
	50 Hz	60 Hz	50 Hz	60 Hz	50 Hz	50 Hz	50 Hz	50 Hz	50 Hz	
56-100	220-240 VΔ 380-420 VY	440-480 VY	380-420 VΔ 660-690 VY	440-480 VΔ -	-	500 VΔ ¹⁾	500 VY	660 VΔ ¹⁾	690 VΔ ¹⁾	Other rated voltage, connection or frequency, 690 V maximum
112-132	220-240 VΔ 380-420 VY	- 440-480 VY	380-420 VΔ 660-690 VY	440-480 VΔ -	415 VΔ	500 VΔ	500 VY	660 VΔ	690 VΔ	
160-280	220, 230 VΔ 380,400,415 VY	- 440 VY	380,400,415VΔ 660, 690 VY	440 VΔ -	415 VΔ	500 VΔ	500 VY	660 VΔ	690 VΔ	

¹⁾ On request.

Code letters for supplementing the product code - two-speed motors

Motor size	Code letter for voltage and frequency						
	A	S	B	D	H	E	X
56-100	-	220-230 V	-	380-400 V	400-415 V	500 V	
112-132	-	220-230 V	-	380-400 V	400-415 V	500 V	Other rated voltage or frequency, 690 V maximum
160-280	220 V	230 V	380 V	400 V	415 V	500 V	

General purpose aluminum motors

Technical data for totally enclosed squirrel cage three phase motors



IP 55 – IC 411 – Insulation class F, temperature rise class B

Output kW	Motor type	Product code	Speed r/min	Efficiency		Power factor cos φ	Current		Torque		
				Full load 100%	3/4 load 75%		I_N	I_s	T_N	T_s	T_{max}
			400 V 50 Hz			Basic design					
0.09	M2VA 56 A	3GVA 051 001-••A	2820	59.8	53.3	0.69	0.32	3.9	0.31	2.9	2.7
0.12	M2VA 56 B	3GVA 051 002-••A	2840	67.2	63.8	0.64	0.41	4.1	0.41	3.2	2.8
0.18	M2VA 63 A	3GVA 061 001-••A	2820	73.7	70.6	0.64	0.56	4.2	0.62	3.5	3.1
0.25	M2VA 63 B	3GVA 061 002-••A	2810	77.5	75.8	0.71	0.66	4.5	0.87	3.6	3.3
0.37	M2VA 71 A	3GVA 071 001-••C	2840	77.1	76.5	0.72	1	5.5	1.25	3.8	3.9
0.55	M2VA 71 B	3GVA 071 002-••C	2830	79.2	78.2	0.76	1.35	5.7	1.86	3.6	3.7
0.75	M2VA 80 A	3GVA 081 001-••B	2870	81.2	79.3	0.75	1.8	6.2	2.49	2.9	3.6
1.1	M2VA 80 B	3GVA 081 002-••B	2850	81.4	79.5	0.78	2.5	6.1	3.69	2.3	3.5
1.5	M2AA 90 S	3GAA 091 001-••E	2870	80.1	76.2	0.82	3.35	5.5	5	2.4	3.0
2.2	M2AA 90 L	3GAA 091 002-••E	2880	83.6	83.9	0.87	4.37	7.0	7.5	2.7	3.0
3	M2AA 100 L	3GAA 101 001-••E	2900	86.0	84.1	0.88	5.95	7.5	10	2.7	3.6
4	M2AA 112 M	3GAA 111 001-••A	2850	86.0	86.0	0.91	7.4	7.5	13.4	2.8	3.0
5.5	M2AA 132 SA	3GAA 131 001-••A	2855	86.0	86.0	0.88	10.5	6.8	18.3	2.7	3.6
7.5	M2AA 132 SB	3GAA 131 002-••A	2855	87.0	87.0	0.90	13.9	7.2	25	3.2	3.8
11	²⁾ M2AA 160 MA	3GAA 161 111-••A	2915	88.4	88.9	0.89	20.5	6.1	36	2.1	2.5
15	²⁾ M2AA 160 M	3GAA 161 112-••A	2900	89.5	89.9	0.90	27	6.1	49.4	2.4	2.6
18.5	²⁾ M2AA 160 L	3GAA 161 113-••A	2915	90.2	90.5	0.91	32.5	6.8	61	2.6	3.0
22	²⁾ M2AA 180 M	3GAA 181 111-••A	2925	91.2	91.3	0.89	39	7.9	72	2.7	3.4
30	²⁾ M2AA 200 LA	3GAA 201 011-••A	2945	92.0	92.0	0.88	53	7.9	97	3.0	3.7
37	^{2) 3)} M2AA 200 L	3GAA 201 012-••A	2945	92.8	92.9	0.89	65	8.2	120	3.1	3.6
45	M2AA 225 M	3GAA 221 011-••A	2940	93.0	93.0	0.88	80	7.7	146	2.8	3.0
55	²⁾ M2AA 250 M	3GAA 251 011-••A	2960	93.5	93.8	0.90	95	7.3	177	2.8	3.0

¹⁾ Temperature rise class F.

²⁾ Temperature rise class F for 380 V 50 Hz.

³⁾ Temperature rise class F for 415 V 50 Hz.

The bullets in the product code indicate choice of mounting arrangement, voltage and frequency, generation code (see ordering information page).

General purpose aluminum motors

Technical data for totally enclosed squirrel cage three phase motors

IP 55 – IC 411 – Insulation class F, temperature rise class B

Output kW	Motor type	Speed r/min	Efficiency %	Power factor cos φ	Current I _N A	Speed r/min	Efficiency %	Power factor cos φ	Current I _N A	Moment of inertia J=1/4 GD ² kgm ²	Weight kg	Sound pressure level L _p dB(A)
3000 r/min = 2-poles		380 V 50 Hz				415 V 50 Hz						
0.09	M2VA 56 A	2805	58.6	0.72	0.32	2830	57.8	0.65	0.34	0.00011	3.2	48
0.12	M2VA 56 B	2825	69.2	0.68	0.4	2850	64.5	0.59	0.45	0.00012	3.4	48
0.18	M2VA 63 A	2815	74.6	0.69	0.53	2830	72.5	0.60	0.58	0.00013	3.9	54
0.25	M2VA 63 B	2800	78.5	0.75	0.64	2830	76.2	0.67	0.69	0.00016	4.4	54
0.37	M2VA 71 A	2830	77.3	0.75	1	2855	75.6	0.68	1.05	0.0004	5.5	58
0.55	M2VA 71 B	2820	80.2	0.81	1.31	2845	77.7	0.73	1.38	0.00045	6.5	58
0.75	M2VA 80 A	2850	82.2	0.80	1.73	2880	79.2	0.68	1.9	0.000722	9	60
1.1	M2VA 80 B	2830	81.1	0.84	2.47	2870	80.2	0.74	2.6	0.000763	11	60
1.5	M2AA 90 S	2850	79.7	0.88	3.4	2890	79.8	0.79	3.4	0.0019	13	63
2.2	M2AA 90 L	2860	83.0	0.89	4.6	2890	83.3	0.84	4.2	0.0024	16	63
3	M2AA 100 L	2890	86.0	0.90	6.15	2910	86.0	0.85	5.95	0.0041	21	65
4	M2AA 112 M	2830	85.0	0.92	7.8	2865	86.5	0.90	7.2	0.01	25	63
5.5	M2AA 132 SA	2840	85.0	0.90	10.9	2865	86.5	0.87	10.2	0.014	37	69
7.5	M2AA 132 SB	2850	86.0	0.91	14.7	2870	87.5	0.88	13.6	0.016	42	69
11 ²⁾	M2AA 160 MA	2905	87.9	0.90	21.5	2920	88.7	0.88	20	0.039	73	73
15 ²⁾	M2AA 160 M	2890	88.9	0.91	28.5	2905	89.8	0.90	26	0.047	84	73
18.5 ²⁾	M2AA 160 L	2905	89.2	0.91	34.5	2925	90.4	0.90	31.5	0.053	94	73
22 ²⁾	M2AA 180 M	2915	90.5	0.91	40.5	2930	91.4	0.87	38.5	0.06	111	75
30 ²⁾	M2AA 200 LA	2940	91.4	0.89	56	2950	92.1	0.86	52	0.094	139	75
37 ²⁾³⁾	M2AA 200 L	2940	92.3	0.91	67	2950	92.9	0.88	63	0.115	170	75
45	M2AA 225 M	2940	93.2	0.89	83	2950	93.8	0.87	78	0.21	209	75
55 ²⁾	M2AA 250 M	2955	93.9	0.90	100	2965	94.3	0.88	93	0.31	277	74

Recalculation factors

Recalculation factors for current at rated voltages other than 400 V 50 Hz.			
Rated voltage at 50 Hz and motor wound for	Recalculation factor	Rated voltage at 50 Hz and motor wound for	Recalculation factor
220 V	1.82	500 V	0.80
230 V	1.74	660 V	0.61
415 V	0.96	690 V	0.58

General purpose aluminum motors

Technical data for totally enclosed squirrel cage three phase motors



IP 55 – IC 411 – Insulation class F, temperature rise class B

Output kW	Motor type	Product code	Speed r/min	Efficiency		Power factor cos φ 100%	Current		Torque				
				Full load 100%	3/4 load 75%		I _N A	I _s / I _N	T _N Nm	T _s / T _N	T _{max} / T _N		
1500 r/min = 4-poles			400 V 50 Hz				Basic design						
0.06	M2VA 56 A	3GVA 052 001-••A	1340	51.1	45.8	0.67	0.26	2.5	0.43	2.2	2.2		
0.09	M2VA 56 B	3GVA 052 002-••A	1370	55.5	50.2	0.62	0.38	2.8	0.63	2.9	2.9		
0.12	M2VA 63 A	3GVA 062 001-••A	1400	63.7	58.4	0.59	0.46	3.1	0.82	2.6	2.6		
0.18	M2VA 63 B	3GVA 062 002-••A	1380	65.6	62.1	0.64	0.63	3.1	1.25	2.5	2.6		
0.25	M2VA 71 A	3GVA 072 001-••C	1410	70.4	69.1	0.71	0.74	4.3	1.71	2.7	2.9		
0.37	M2VA 71 B	3GVA 072 002-••C	1420	74.6	72.1	0.69	1.05	4.4	2.51	2.6	2.8		
0.55	M2VA 80 A	3GVA 082 001-••B	1390	75.3	73.1	0.76	1.4	4.6	3.75	2.6	2.9		
0.75	M2VA 80 B	3GVA 082 002-••B	1410	78.2	75.6	0.74	1.9	4.7	5.08	3.5	3.9		
1.1	M2AA 90 S	3GAA 092 001-••E	1410	77.5	76.4	0.81	2.59	5.0	7.5	2.2	2.7		
1.5	M2AA 90 L	3GAA 092 002-••E	1420	80.3	78.1	0.79	3.45	5.0	10	2.4	2.9		
2.2	M2AA 100 LA	3GAA 102 001-••E	1430	83.0	82.7	0.81	4.8	5.5	15	2.4	2.9		
3	M2AA 100 LB	3GAA 102 002-••E	1430	85.0	83.9	0.81	6.48	5.5	20	2.5	2.9		
4	M2AA 112 M	3GAA 112 001-••A	1435	84.5	85.5	0.80	8.6	7.0	27	2.8	3.0		
5.5	M2AA 132 S	3GAA 132 001-••A	1450	87.0	87.0	0.83	11.1	7.3	36	2.2	3.0		
7.5	M2AA 132 M	3GAA 132 002-••A	1450	88.0	88.0	0.83	14.8	7.9	49	2.5	3.2		
11	²⁾ M2AA 160 M	3GAA 162 111-••A	1460	89.1	89.8	0.81	22	6.5	72	2.7	2.6		
15	²⁾ M2AA 160 L	3GAA 162 112-••A	1460	90.4	91.0	0.82	29	7.1	98	2.7	3.3		
18.5	²⁾ M2AA 180 M	3GAA 182 111-••A	1460	91.1	91.5	0.81	36.5	7.6	121	3.1	3.5		
22	²⁾ M2AA 180 L	3GAA 182 112-••A	1460	91.8	92.3	0.82	42	7.9	143	3.0	3.8		
30	²⁾ M2AA 200 L	3GAA 202 011-••A	1470	92.0	92.1	0.80	59	7.8	195	3.0	3.4		
37	²⁾ M2AA 225 S	3GAA 222 011-••A	1475	92.8	93.0	0.85	68	6.8	240	3.0	3.1		
45	²⁾ M2AA 225 M	3GAA 222 012-••A	1475	93.0	93.1	0.84	84	8.1	291	3.5	3.2		
55	²⁾ M2AA 250 M	3GAA 252 011-••A	1475	93.7	94.3	0.84	98	6.8	356	2.5	2.6		

²⁾ Temperature rise class F for 380 V 50 Hz.

General purpose aluminum motors

Technical data for totally enclosed squirrel cage three phase motors

IP 55 – IC 411 – Insulation class F, temperature rise class B

Output kW	Motor type	Speed r/min	Efficiency %	Power factor cos φ	Current I _N A	Speed r/min	Efficiency %	Power factor cos φ	Current I _N A	Moment of inertia J=1/4 GD ² kgm ²	Weight kg	Sound pressure level L _p dB(A)
1500 r/min = 4-poles		380 V 50 Hz				415 V 50 Hz						
0.06	M2VA 56 A	1335	50.5	0.70	0.26	1360	49.9	0.63	0.28	0.00017	3.2	36
0.09	M2VA 56 B	1360	57.1	0.66	0.37	1390	54.9	0.58	0.4	0.00018	3.4	36
0.12	M2VA 63 A	1390	63.1	0.63	0.44	1400	62.5	0.55	0.49	0.00019	4	40
0.18	M2VA 63 B	1370	66.9	0.67	0.63	1400	64.3	0.59	0.67	0.00026	4.5	40
0.25	M2VA 71 A	1400	69.9	0.74	0.75	1420	69.2	0.67	0.77	0.00066	5.5	45
0.37	M2VA 71 B	1410	74.6	0.73	1.02	1430	73.4	0.65	1.1	0.00089	6.5	45
0.55	M2VA 80 A	1380	75.5	0.82	1.35	1400	73.8	0.68	1.55	0.001257	9	50
0.75	M2VA 80 B	1400	78.7	0.81	1.8	1410	76.0	0.67	2.05	0.001565	10.5	50
1.1	M2AA 90 S	1410	76.3	0.83	2.66	1430	77.7	0.76	2.6	0.0032	13	50
1.5	M2AA 90 L	1420	79.9	0.82	3.5	1430	80.3	0.77	3.45	0.0043	16	50
2.2	M2AA 100 LA	1430	83.0	0.83	4.83	1430	83.0	0.78	4.85	0.0069	21	64
3	M2AA 100 LB	1430	85.0	0.85	6.58	1430	85.0	0.77	6.55	0.0082	24	66
4	M2AA 112 M	1425	84.0	0.80	8.9	1440	85.0	0.75	8.8	0.015	27	56
5.5	M2AA 132 S	1445	86.0	0.85	11.5	1455	87.5	0.81	10.9	0.031	40	59
7.5	M2AA 132 M	1445	87.0	0.85	15.3	1455	88.0	0.81	14.5	0.038	48	59
11	²⁾ M2AA 160 M	1450	88.1	0.83	23	1465	89.2	0.79	22	0.067	75	62
15	²⁾ M2AA 160 L	1455	89.5	0.84	30	1465	90.5	0.80	29	0.088	92	62
18.5	²⁾ M2AA 180 M	1455	90.4	0.83	37.5	1465	91.2	0.79	36.5	0.102	110	64
22	²⁾ M2AA 180 L	1455	91.1	0.84	43.5	1465	91.9	0.81	41.5	0.127	128	64
30	²⁾ M2AA 200 L	1470	92.3	0.82	60	1475	92.6	0.77	58	0.225	177	67
37	²⁾ M2AA 225 S	1470	92.4	0.86	71	1475	93.2	0.83	67	0.35	216	68
45	²⁾ M2AA 225 M	1470	93.2	0.85	87	1475	93.8	0.82	83	0.41	237	68
55	²⁾ M2AA 250 M	1470	93.3	0.86	103	1475	94.1	0.84	95	0.5	286	66

Recalculation factors

Recalculation factors for current at rated voltages other than 400 V 50 Hz.			
Rated voltage at 50 Hz and motor wound for	Recalculation factor	Rated voltage at 50 Hz and motor wound for	Recalculation factor
220 V	1.82	500 V	0.80
230 V	1.74	660 V	0.61
415 V	0.96	690 V	0.58

General purpose aluminum motors

Technical data for totally enclosed squirrel cage three phase motors



IP 55 – IC 411 – Insulation class F, temperature rise class B

Output kW	Motor type	Product code	Speed r/min	Efficiency		Power factor cos φ	Current		Torque			
				Full load 100%	3/4 load 75%		I _N A	I _s / I _N	T _N Nm	T _s / T _N	T _{max} / T _N	
3000 r/min = 2-poles			400 V 50 Hz				Basic design					
1.1	M3VA 80 C	3GVA 081 313-••B	2850	82.8	82.6	0.85	2.25	8.1	3.69	4.2	3.5	
1.5	M3AA 90 L	3GAA 091 312-••E	2900	85.9	86.5	0.87	3.2	7.7	5	2.7	3.6	
2.2	M3AA 90 LB	3GAA 091 313-••E	2880	85.8	87.1	0.87	4.4	7.4	7.3	3.0	3.6	
3	M3AA 100 LB	3GAA 101 312-••E	2920	87.6	87.5	0.86	5.9	10.0	9.9	3.9	4.9	
4	M3AA 112 M	3GAA 111 022-••C	2860	87.7	89.4	0.93	7.1	7.5	13.4	2.6	3.4	
5.5	M3AA 132 SA	3GAA 131 023-••C	2900	88.6	88.9	0.88	10.1	9.2	18.1	3.8	4.5	
7.5	M3AA 132 SB	3GAA 131 024-••C	2915	90.9	91.3	0.90	13.3	11.0	24.6	5.1	5.2	
11	M3AA 160 MA	3GAA 161 101-••C	2930	91.0	91.2	0.88	20	6.2	36	2.1	2.8	
15	M3AA 160 M	3GAA 161 102-••C	2920	91.3	91.7	0.90	26.5	6.4	49	2.3	2.7	
18.5	M3AA 160 L	3GAA 161 103-••C	2920	92.4	93.1	0.91	32	7.2	61	2.6	2.9	
22	M3AA 180 M	3GAA 181 101-••C	2930	92.8	93.3	0.89	38.5	7.2	71	2.7	3.0	
30	M3AA 200 MLA	3GAA 201 001-••C	2955	93.2	93.2	0.88	53	8.5	97	2.9	3.1	
37	M3AA 200 MLB	3GAA 201 002-••C	2950	93.6	93.7	0.89	64	7.2	120	2.3	2.9	
45	M3AA 225 SMB	3GAA 221 001-••C	2960	94.1	93.9	0.88	79	7.7	145	2.5	2.9	
55	M3AA 250 SMA	3GAA 251 001-••C	2970	94.2	93.8	0.89	95	7.9	177	2.4	3.0	
75	M3AA 280 SMA	3GAA 281 001-••C	2970	94.7	94.4	0.90	127	8.2	241	2.7	3.2	
90	¹⁾ M3AA 280 SMB	3GAA 281 002-••C	2970	95.4	94.8	0.90	152	8.3	290	2.7	3.4	
3000 r/min = 2-poles			400 V 50 Hz				High-output design					
0.37	M2VA 63 BB	3GVA 061 003-••A	2800	73.6	73.1	0.81	0.9	3.5	1.29	2.3	2.2	
0.68	M2VA 71 BB	3GVA 071 003-••C	2800	78.9	77.4	0.82	1.59	5.2	2.33	3.2	3.3	
0.75	M2VA 71 BC	3GVA 071 004-••C	2800	78.5	77.9	0.85	1.7	5.1	2.57	3.1	3.2	
1.5	M2VA 80 C	3GVA 081 003-••B	2840	82.4	82.2	0.83	3.16	5.5	5.13	2.8	3.1	
2.7	¹⁾ M3AA 90 LB	3GAA 091 003-••E	2860	80.7	83.5	0.86	5.7	7.0	9	2.6	3.0	
4	¹⁾ M3AA 100 LB	3GAA 101 002-••E	2900	85.0	84.3	0.86	8.1	7.5	13	2.7	3.6	
5.5	¹⁾ M3AA 112 MB	3GAA 111 002-••C	2855	86.5	86.5	0.93	9.9	7.3	18.4	2.6	3.5	
9.2	¹⁾ M3AA 132 SBB	3GAA 131 004-••C	2840	86.8	88.3	0.92	16.8	8.5	31	3.3	3.6	
11	¹⁾ M3AA 132 SC	3GAA 131 003-••C	2835	87.0	87.0	0.93	19.6	8.0	37	3.2	3.3	
22	¹⁾ M3AA 160 LB	3GAA 161 104-••C	2920	92.0	93.0	0.91	38	6.9	72	2.3	2.9	
30	M3AA 180 LB	3GAA 181 102-••C	2945	93.7	94.0	0.89	53	7.8	97	2.7	3.0	
45	M3AA 200 MLC	3GAA 201 003-••C	2950	94.1	94.5	0.89	78	8.2	146	3.0	3.2	
55	M3AA 225 SMC	3GAA 221 002-••C	2960	94.5	94.6	0.89	95	7.3	177	2.8	3.0	
55	¹⁾ M3AA 200 MLD	3GAA 201 004-••C	2940	94.0	94.4	0.89	95	7.9	179	3.1	3.1	
75	M3AA 250 SMB	3GAA 251 002-••C	2970	94.7	94.4	0.90	127	8.2	241	2.7	3.2	
80	¹⁾ M3AA 225 SMD	3GAA 221 003-••C	2960	94.7	94.7	0.86	143	7.5	258	2.9	3.1	
95	¹⁾ M3AA 250 SMC	3GAA 251 003-••C	2965	95.4	95.6	0.90	160	8.0	306	2.6	3.1	

¹⁾ Temperature rise class F.

²⁾ On request.

The bullets in the product code indicate choice of mounting arrangement, voltage and frequency, generation code (see ordering information page).

General purpose aluminum motors

Technical data for totally enclosed squirrel cage three phase motors

IP 55 – IC 411 – Insulation class F, temperature rise class B

Output kW	Motor type	Speed r/min	Efficiency %	Power factor cos φ	Current I _N A	Speed r/min	Efficiency %	Power factor cos φ	Current I _N A	Moment of inertia J=1/4 GD ² kgm ²	Weight kg	Sound pressure level L _p dB(A)
3000 r/min = 2-poles		380 V 50 Hz				415 V 50 Hz						
1.1	M3VA 80 C	2830	81.1	0.88	2.35	2870	81.2	0.80	2.35	0.001093	11	60
1.5	M3AA 90 L	2880	85.1	0.87	3.4	2910	85.9	0.84	3.1	0.0024	16	63
2.2	M3AA 90 LB	2860	85.1	0.88	4.5	2890	86.1	0.84	4.3	0.0027	18	63
3	M3AA 100 LB	2910	87.5	0.87	6.1	2930	87.7	0.83	5.8	0.005	25	62
4	M3AA 112 M	2860	86.7	0.93	7.6	2860	88.0	0.93	6.9	0.012	33	63
5.5	M3AA 132 SA	2900	88.6	0.89	10.7	2900	88.8	0.86	9.9	0.016	42	69
7.5	M3AA 132 SB	2915	90.5	0.90	13.9	2915	91.2	0.90	12.9	0.022	56	69
11	M3AA 160 MA	2915	90.8	0.89	20.5	2935	91.0	0.86	19.4	0.039	73	69
15	M3AA 160 M	2905	91.0	0.90	27.5	2925	91.4	0.89	25.5	0.047	84	69
18.5	M3AA 160 L	2910	92.0	0.91	33.5	2930	92.6	0.90	31	0.053	94	69
22	M3AA 180 M	2930	92.4	0.90	40.5	2945	93.0	0.88	37.5	0.077	119	69
30	M3AA 200 MLA	2955	93.0	0.89	55	2960	93.3	0.86	52	0.15	175	72
37	M3AA 200 MLB	2950	93.4	0.89	68	2955	93.7	0.87	63	0.18	200	72
45	M3AA 225 SMB	2955	94.0	0.89	82	2965	94.2	0.87	77	0.26	235	74
55	M3AA 250 SMA	2960	94.1	0.89	100	2970	94.2	0.88	92	0.49	285	75
75	M3AA 280 SMA	2965	94.6	0.90	134	2970	94.7	0.89	123	0.57	375	75
90 ¹⁾	M3AA 280 SMB	2965	95.3	0.89	158	2970	95.4	0.91	148	0.59	390	75
3000 r/min = 2-poles		380 V 50 Hz				415 V 50 Hz						
0.37	M2VA 63 BB	2790	71.6	0.84	0.92	2820	72.4	0.77	0.94	0.00036	4.9	54
0.68	M2VA 71 BB	2790	77.4	0.85	1.6	2810	77.4	0.78	1.63	0.00045	6.5	58
0.75	M2VA 71 BC	2790	76.0	0.87	1.75	2810	77.0	0.78	1.8	0.00045	6.5	58
1.5	M2VA 80 C	2800	80.9	0.88	3.2	2820	83.2	0.81	3.1	0.001093	11.5	60
2.7 ¹⁾	M3AA 90 LB	2840	80.2	0.89	5.8	2870	80.6	0.83	5.7	0.0027	18	68
4 ¹⁾	M3AA 100 LB	2890	85.0	0.88	8.3	2910	85.0	0.84	7.8	0.005	25	68
5.5 ¹⁾	M3AA 112 MB	2835	85.5	0.93	10.5	2865	87.5	0.92	9.5	0.012	33	63
9.2 ¹⁾	M3AA 132 SBB	2830	85.8	0.92	17.6	2850	87.4	0.93	16.2	0.02	50	69
11 ¹⁾	M3AA 132 SC	2815	86.5	0.93	21	2845	88.0	0.93	18.9	0.022	56	69
22 ¹⁾	M3AA 160 LB	2910	91.6	0.91	40	2925	92.4	0.90	37	0.058	100	69
30	M3AA 180 LB	2940	93.9	0.90	55	2950	93.8	0.87	52	0.092	137	70
45	M3AA 200 MLC	2945	94.0	0.89	82	2955	94.2	0.88	76	0.19	205	72
55	M3AA 225 SMC	2950	94.3	0.89	100	2965	94.7	0.88	92	0.29	260	74
55 ¹⁾	M3AA 200 MLD ²⁾									0.2	215	
75	M3AA 250 SMB	2965	94.6	0.90	134	2970	94.7	0.89	123	0.57	375	75
80 ¹⁾	M3AA 225 SMD ²⁾									0,3	275	74
95 ¹⁾	M3AA 250 SMC ²⁾									0,59	345	75

Recalculation factors

Recalculation factors for current at rated voltages other than 400 V 50 Hz.			
Rated voltage at 50 Hz and motor wound for	Recalculation factor	Rated voltage at 50 Hz and motor wound for	Recalculation factor
220 V	1.82	500 V	0.80
230 V	1.74	660 V	0.61
415 V	0.96	690 V	0.58

General purpose aluminum motors

Technical data for totally enclosed squirrel cage three phase motors



IP 55 – IC 411 – Insulation class F, temperature rise class B

Output kW	Motor type	Product code	Speed r/min	Efficiency		Power factor cos φ	Current		Torque				
				Full load 100%	3/4 load 75%		I _N A	I _s / I _N	T _N Nm	T _s / T _N	T _{max} / T _N		
1500 r/min = 4-poles			400 V 50 Hz				Basic design						
1.1	M3AA 90 L	3GAA 092 312-••E	1420	83.9	84.3	0.80	2.4	6.1	7.4	2.9	3.4		
1.5	M3AA 100 LA	3GAA 102 311-••E	1440	85.6	85.5	0.82	3.2	6.9	10	2.8	3.4		
2.2	M3AA 100 LC	3GAA 102 313-••E	1450	86.8	86.5	0.77	4.8	8.5	14.5	4.0	4.6		
3	M3AA 112 MA	3GAA 112 021-••C	1455	87.5	87.8	0.81	6.2	7.9	19.7	2.7	3.7		
4	M3AA 112 M	3GAA 112 022-••C	1455	88.3	88.6	0.76	8.6	8.5	26.3	3.3	4.3		
5.5	M3AA 132 S	3GAA 132 023-••C	1460	89.3	90.5	0.84	10.6	7.0	36.2	2.2	2.8		
7.5	M3AA 132 M	3GAA 132 024-••C	1450	90.3	91.0	0.87	14	7.8	49	2.2	3.1		
11	M3AA 160 M	3GAA 162 101-••C	1460	92.0	92.7	0.81	21.5	7.8	72	3.3	3.2		
15	M3AA 160 L	3GAA 162 102-••C	1460	91.8	92.5	0.82	29	8.1	98	3.0	3.6		
18.5	M3AA 180 M	3GAA 182 101-••C	1470	92.3	92.9	0.84	35	7.0	120	2.9	2.9		
22	M3AA 180 L	3GAA 182 102-••C	1470	93.1	93.9	0.85	40	7.1	143	3.1	3.3		
30	M3AA 200 MLB	3GAA 202 001-••C	1475	93.4	94.0	0.84	55	7.5	194	2.5	2.8		
37	M3AA 225 SMA	3GAA 222 001-••C	1480	93.6	93.8	0.84	68	7.6	239	3.1	3.3		
45	M3AA 225 SMB	3GAA 222 002-••C	1480	94.2	94.4	0.83	83	7.6	291	3.4	3.0		
55	M3AA 250 SMA	3GAA 252 001-••C	1480	94.6	94.9	0.86	98	7.6	355	3.1	3.0		
75	M3AA 280 SMA	3GAA 282 001-••C	1480	94.8	95.3	0.86	132	7.1	486	3.2	3.0		
90	M3AA 280 SMB	3GAA 282 002-••C	1475	95.0	95.3	0.87	157	7.7	583	3.3	3.2		
1500 r/min = 4-poles			400 V 50 Hz				High-output design						
0.25	M2VA 63 BB	3GVA 062 003-••A	1370	70.3	67.4	0.67	0.78	3.2	1.75	2.5	2.1		
0.45	M2VA 71 BB	3GVA 072 003-••C	1390	75.5	75.3	0.76	1.15	4.1	3.11	2.1	2.3		
0.55	M2VA 71 C	3GVA 072 004-••C	1410	77.3	76.9	0.73	1.45	4.8	3.74	2.7	2.9		
0.95	M2VA 80 C	3GVA 082 003-••B	1410	78.9	77.9	0.75	2.35	4.3	6.44	2.9	3.3		
1.1	M2VA 80 C	3GVA 082 004-••B	1390	74.7	76.6	0.77	2.8	4.3	7.8	3.1	2.3		
1.85	¹⁾ M3AA 90 L	3GAA 092 003-••E	1390	79.5	78.1	0.80	4.4	4.5	13	2.2	2.4		
2.2	¹⁾ M3AA 90 LB	3GAA 092 004-••E	1390	80.3	81.0	0.83	4.85	4.5	15	2.2	2.4		
4	¹⁾ M3AA 100 LC	3GAA 102 003-••E	1420	81.0	81.7	0.82	8.65	5.5	27	2.5	2.8		
5.5	¹⁾ M3AA 112 MB	3GAA 112 002-••C	1425	84.5	85.5	0.83	11.4	7.1	37	2.8	3.1		
9.2	¹⁾ M3AA 132 MBA	3GAA 132 004-••C	1445	87.8	89.2	0.87	17.5	7.2	61	2.7	2.7		
11	¹⁾ M3AA 132 MB	3GAA 132 003-••C	1450	88.8	89.9	0.86	21	7.7	72	2.5	2.5		
18.5	¹⁾ M3AA 160 LB	3GAA 162 103-••C	1450	90.5	92.0	0.84	36	6.6	122	2.6	3.0		
30	¹⁾ M3AA 180 LB	3GAA 182 103-••C	1465	92.5	93.3	0.84	56	6.8	196	2.5	2.8		
37	M3AA 200 MLB	3GAA 202 002-••C	1475	93.4	94.0	0.84	68	7.9	240	3.8	3.2		
48	¹⁾ M3AA 200 MLC	3GAA 202 003-••C	1470	93.6	94.1	0.84	89	8.1	311	4.4	3.2		
55	M3AA 225 SMC	3GAA 222 003-••C	1480	94.6	95.0	0.84	100	7.5	356	3.5	3.0		
73	¹⁾ M3AA 225 SMD	3GAA 222 004-••C	1475	94.2	94.5	0.85	132	8.1	473	3.9	3.2		
75	M3AA 250 SMB	3GAA 252 002-••C	1480	94.8	95.3	0.86	132	7.1	486	3.2	3.0		
95	¹⁾ M3AA 250 SMC	3GAA 252 003-••C	1475	94.8	95.5	0.88	165	7.3	616	2.7	3.1		

¹⁾ Temperature rise class F.

²⁾ On request.

The bullets in the product code indicate choice of mounting arrangement, voltage and frequency, generation code (see ordering information page).

General purpose aluminum motors

Technical data for totally enclosed squirrel cage three phase motors

IP 55 – IC 411 – Insulation class F, temperature rise class B

Output kW	Motor type	Speed r/min	Efficiency %	Power factor cos φ	Current I _N A	Speed r/min	Efficiency %	Power factor cos φ	Current I _N A	Moment of inertia J=1/4 GD ² kgm ²	Weight kg	Sound pressure level L _p dB(A)
1500 r/min = 4-poles		380 V 50 Hz				415 V 50 Hz						
1.1	M3AA 90 L	1410	83.6	0.82	2.5	1430	84.4	0.78	2.4	0.0043	16	50
1.5	M3AA 100 LA	1430	85.4	0.84	3.2	1450	86.1	0.79	3.1	0.0069	21	54
2.2	M3AA 100 LC	1440	86.8	0.80	4.8	1460	86.9	0.74	4.8	0.009	25	54
3	M3AA 112 MA	1455	87.2	0.81	6.5	1455	87.8	0.80	6.1	0.018	34	56
4	M3AA 112 M	1455	87.9	0.77	9.0	1455	88.6	0.77	8.2	0.018	34	56
5.5	M3AA 132 S	1460	88.9	0.84	11.1	1460	89.1	0.84	10.3	0.038	48	59
7.5	M3AA 132 M	1450	89.9	0.87	14.7	1450	90.3	0.87	13.5	0.048	59	59
11	M3AA 160 M	1460	91.1	0.83	22.5	1470	91.6	0.82	20.5	0.067	94	62
15	M3AA 160 L	1455	91.8	0.84	30	1465	91.9	0.81	28	0.102	103	62
18.5	M3AA 180 M	1465	91.7	0.85	36	1470	92.2	0.83	34	0.161	124	62
22	M3AA 180 L	1465	92.7	0.86	42	1475	93.3	0.84	38	0.225	161	63
30	M3AA 200 MLB	1470	93.1	0.85	58	1475	93.5	0.84	54	0.34	205	63
37	M3AA 225 SMA	1475	93.6	0.84	72	1480	93.8	0.81	68	0.37	215	66
45	M3AA 225 SMB	1475	94.0	0.85	86	1480	94.2	0.81	82	0.42	230	66
55	M3AA 250 SMA	1475	94.4	0.86	103	1480	94.5	0.84	96	0.72	275	67
75	M3AA 280 SMA	1475	94.5	0.87	139	1480	94.8	0.86	128	0.88	380	67
90	M3AA 280 SMB	1470	95.0	0.89	164	1475	95.1	0.87	153	0.95	405	67

1500 r/min = 4-poles		380 V 50 Hz				415 V 50 Hz						
0.25	M2VA 63 BB	1360	70.9	0.71	0.76	1380	69.1	0.63	0.8	0.0003	5	40
0.45	M2VA 71 BB	1380	75.1	0.80	1.12	1400	74.0	0.72	1.2	0.00089	6.5	45
0.55	M2VA 71 C	1400	77.0	0.77	1.4	1420	76.1	0.69	1.5	0.0011	7	45
0.95	M2VA 80 C	1400	79.1	0.81	2.3	1430	76.4	0.66	2.65	0.001948	11	50
1.1	M2VA 80 C	1380	74.3	0.82	2.7	1400	74.1	0.72	2.9	0.001948	11	50
1.85	¹⁾ M3AA 90 L	1380	78.8	0.83	4.4	1400	79.5	0.76	4.35	0.0043	16	50
2.2	¹⁾ M3AA 90 LB	1380	78.4	0.85	5.1	1400	80.8	0.80	4.9	0.0048	17	50
4	¹⁾ M3AA 100 LC	1410	80.0	0.82	8.8	1420	82.0	0.75	8.7	0.009	25	60
5.5	¹⁾ M3AA 112 MB	1415	84.5	0.85	11.7	1430	85.5	0.79	11.4	0.018	34	56
9.2	¹⁾ M3AA 132 MBA	1445	88.0	0.87	18.4	1445	88.3	0.87	16.8	0.048	59	59
11	¹⁾ M3AA 132 MB	1445	88.2	0.87	22	1455	88.9	0.83	21	0.048	59	59
18.5	¹⁾ M3AA 160 LB	1440	89.8	0.85	37	1450	90.8	0.83	34	0.102	103	63
30	¹⁾ M3AA 180 LB	1465	92.2	0.85	58	1470	92.7	0.82	55	0.225	161	63
37	M3AA 200 MLB	1475	93.3	0.85	71	1475	93.3	0.82	67	0.34	205	63
48	¹⁾ M3AA 200 MLC ²⁾									0.38	270	63
55	M3AA 225 SMC	1475	94.3	0.84	105	1480	94.6	0.82	99	0.49	265	66
73	¹⁾ M3AA 225 SMD ²⁾									0.56	290	66
75	M3AA 250 SMB	1475	94.5	0.87	139	1480	94.8	0.86	128	0.88	335	67

Recalculation factors

Recalculation factors for current at rated voltages other than 400 V 50 Hz.			
Rated voltage at 50 Hz and motor wound for	Recalculation factor	Rated voltage at 50 Hz and motor wound for	Recalculation factor
220 V	1.82	500 V	0.80
230 V	1.74	660 V	0.61
415 V	0.96	690 V	0.58

General purpose aluminum motors

Technical data for totally enclosed squirrel cage three phase motors

IP 55 – IC 411 – Insulation class F, temperature rise class B

Output kW	Motor type	Product code	Speed r/min	Efficiency		Power factor cos φ	Current		Torque			
				Full load 100%	3/4 load 75%		I _N A	I _s A	T _N Nm	T _s Nm	T _{max} Nm	
1000 r/min = 6-poles			400 V 50 Hz				Basic design					
0.09	M2VA 63 A	3GVA 063 001-••A	910	47.1	42.5	0.56	0.51	2.1	0.95	2.1	2.1	
0.12	M2VA 63 B	3GVA 063 002-••A	910	57.5	54.0	0.58	0.54	2.1	1.27	2.1	2.1	
0.18	M2VA 71 A	3GVA 073 001-••C	920	61.1	57.7	0.69	0.64	2.9	1.88	2.1	2.2	
0.25	M2VA 71 B	3GVA 073 002-••C	920	64.9	62.3	0.65	0.86	3.2	2.61	2.5	2.7	
0.37	M2VA 80 A	3GVA 083 001-••B	925	72.9	70.8	0.72	1.04	3.8	3.82	3.1	3.4	
0.55	M2VA 80 B	3GVA 083 002-••B	925	73.3	71.9	0.71	1.55	3.4	5.68	2.9	3.1	
0.75	M3AA 90 S	3GAA 093 001-••E	930	71.5	70.7	0.67	2.36	4.0	7.5	1.9	2.3	
1.1	M3AA 90 L	3GAA 093 002-••E	930	74.4	72.5	0.69	3.25	4.0	11	2.1	2.4	
1.5	M3AA 100 L	3GAA 103 001-••E	950	80.0	77.0	0.71	3.92	4.5	15	1.9	2.3	
2.2	M3AA 112 M	3GAA 113 001-••C	940	80.5	81.0	0.74	5.4	5.6	22	2.1	2.7	
3	M3AA 132 S	3GAA 133 001-••C	960	84.5	84.8	0.75	6.9	6.5	30	2.1	3.0	
4	M3AA 132 MA	3GAA 133 002-••C	960	85.5	86.1	0.78	8.7	7.1	40	2.6	2.8	
5.5	M3AA 132 MB	3GAA 133 003-••C	955	86.0	87.0	0.78	11.9	7.0	55	2.8	2.8	
7.5	M3AA 160 M	3GAA 163 101-••C	970	89.3	90.4	0.79	15.4	6.6	74	1.9	2.6	
11	M3AA 160 L	3GAA 163 102-••C	970	89.8	90.5	0.78	23	6.9	109	2.1	3.4	
15	M3AA 180 L	3GAA 183 101-••C	970	90.8	91.5	0.78	31	6.8	147	2.0	3.3	
18.5	M3AA 200 MLA	3GAA 203 001-••C	985	91.1	91.7	0.81	36	7.0	180	2.7	2.5	
22	M3AA 200 MLB	3GAA 203 002-••C	980	91.7	92.2	0.81	43	6.8	214	2.9	3.0	
30	M3AA 225 SMB	3GAA 223 001-••C	985	92.8	93.0	0.83	56	7.4	290	3.2	2.8	
37	M3AA 250 SMA	3GAA 253 001-••C	985	93.4	93.7	0.83	69	7.2	358	3.2	2.9	
45	¹⁾ M3AA 280 SMA	3GAA 283 001-••C	985	93.4	93.7	0.84	83	7.2	436	3.2	2.8	
1000 r/min = 6-poles			400 V 50 Hz				High-output design					
0.15	M2VA 63 BB	3GVA 063 003-••A	900	56.9	52.1	0.54	0.74	2.2	1.61	2.2	2.3	
0.32	M2VA 71 C	3GVA 073 003-••C	920	64.8	61.6	0.63	1.15	3.2	3.33	2.6	2.8	
0.37	M2VA 71 C	3GVA 073 004-••C	900	60.1	60.4	0.70	1.2	2.6	4.1	2.2	2.0	
0.75	M2VA 80 C	3GVA 083 003-••B	920	67.9	70.5	0.76	2.1	3.4	8.1	2.4	2.2	
1.3	¹⁾ M3AA 90 LB	3GAA 093 003-••E	910	69.0	69.0	0.71	3.85	4.0	13.5	1.9	2.2	
2.2	¹⁾ M3AA 100 LC	3GAA 103 002-••E	940	77.0	72.8	0.71	5.9	4.5	22	1.9	2.3	
3	¹⁾ M3AA 112 MB	3GAA 113 002-••C	935	80.0	81.2	0.76	7.2	5.5	31	2.5	2.7	
6.3	¹⁾ M3AA 132 MC	3GAA 133 004-••C	960	84.9	85.0	0.75	14.5	7.3	63	2.3	3.1	
14	¹⁾ M3AA 160 LB	3GAA 163 103-••C	960	89.8	90.1	0.77	29.5	7.0	138	2.5	3.1	
18.5	¹⁾ M3AA 180 LB	3GAA 183 102-••C	965	90.7	91.7	0.79	37.5	6.1	183	2.1	2.5	
30	¹⁾ M3AA 200 MLC	3GAA 203 003-••C	980	91.7	92.4	0.81	56	7.3	296	3.6	2.9	
37	M3AA 225 SMC	3GAA 223 002-••C	985	93.0	93.6	0.83	69	7.3	360	3.6	2.8	
45	¹⁾ M3AA 250 SMB	3GAA 253 002-••C	985	93.4	93.7	0.84	83	7.2	436	3.2	2.8	

¹⁾ Temperature rise class F.

The bullets in the product code indicate choice of mounting arrangement, voltage and frequency, generation code (see ordering information page).

General purpose aluminum motors

Technical data for totally enclosed squirrel cage three phase motors

IP 55 – IC 411 – Insulation class F, temperature rise class B

Output kW	Motor type		Speed r/min	Efficiency %	Power factor cos φ	Current I _N A	Speed r/min	Efficiency %	Power factor cos φ	Current I _N A	Moment of inertia J=1/4 GD ² kgm ²	Weight kg	Sound pressure level L _p dB(A)
1000 r/min = 6-poles			380 V 50 Hz				415 V 50 Hz						
0.09	M2VA	63 A	905	49.6	0.59	0.46	925	44.9	0.52	0.55	0.0002	4	38
0.12	M2VA	63 B	905	59.1	0.61	0.52	925	54.8	0.54	0.57	0.00027	4.5	38
0.18	M2VA	71 A	910	60.3	0.73	0.62	930	59.8	0.62	0.7	0.00063	5.5	42
0.25	M2VA	71 B	910	65.4	0.68	0.85	930	63.6	0.61	0.9	0.00081	6.5	42
0.37	M2VA	80 A	905	72.7	0.77	1.03	920	71.4	0.66	1.1	0.001842	9	47
0.55	M2VA	80 B	905	73.1	0.77	1.5	915	71.2	0.65	1.65	0.002176	10	47
0.75	M3AA	90 S	920	70.6	0.72	2.3	930	70.6	0.64	2.36	0.0032	13	44
1.1	M3AA	90 L	920	73.9	0.73	3.2	930	74.2	0.66	3.25	0.0043	16	44
1.5	M3AA	100 L	940	79.0	0.74	3.96	960	80.0	0.67	3.95	0.0082	23	49
2.2	M3AA	112 M	930	80.0	0.78	5.4	950	80.5	0.71	5.4	0.015	27	54
3	M3AA	132 S	955	84.0	0.77	7.1	965	84.0	0.72	6.9	0.031	39	61
4	M3AA	132 MA	955	85.0	0.81	8.9	965	85.5	0.75	8.7	0.038	46	61
5.5	M3AA	132 MB	950	85.5	0.81	12.2	960	86.0	0.76	11.8	0.045	54	61
7.5	M3AA	160 M	960	88.7	0.80	16.1	970	89.6	0.77	15.1	0.089	88	59
11	M3AA	160 L	960	89.4	0.80	23.5	970	90.0	0.76	22.5	0.107	102	59
15	M3AA	180 L	970	90.9	0.79	32	975	91.1	0.74	31	0.217	151	59
18.5	M3AA	200 MLA	980	90.8	0.81	38	985	91.1	0.78	36	0.37	165	63
22	M3AA	200 MLB	980	91.6	0.81	45	985	91.8	0.79	42	0.43	185	63
30	M3AA	225 SMB	985	92.6	0.83	59	985	92.9	0.82	55	0.64	225	63
37	M3AA	250 SMA	985	93.3	0.84	72	990	93.5	0.81	67	1.16	280	63
45	¹⁾ M3AA	280 SMA	985	93.5	0.84	87	985	93.6	0.83	81	1.49	375	63
1000 r/min = 6-poles			380 V 50 Hz				415 V 50 Hz						
0.15	M2VA	63 BB	895	55.9	0.59	0.71	915	53.9	0.52	0.8	0.00032	5	38
0.32	M2VA	71 C	910	65.6	0.67	1.1	930	63.3	0.59	1.2	0.0011	7	42
0.37	M2VA	71 C	880	59.1	0.75	1.25	920	59.8	0.66	1.2	0.0011	7	42
0.75	M2VA	80 C	900	66.9	0.80	2.1	930	67.6	0.72	2.2	0.002576	10	47
1.3	¹⁾ M3AA	90 LB	900	69.0	0.75	3.8	920	69.0	0.67	3.9	0.0048	18	44
2.2	¹⁾ M3AA	100 LC	930	76.0	0.75	5.9	940	77.0	0.67	5.9	0.009	26	49
3	¹⁾ M3AA	112 MB	925	79.5	0.79	7.3	940	80.0	0.73	7.2	0.018	33	54
6.3	¹⁾ M3AA	132 MC	960	84.8	0.75	14.5	965	84.6	0.71	14.4	0.049	59	61
14	¹⁾ M3AA	160 LB	955	89.7	0.79	30.5	965	89.6	0.75	29.5	0.127	117	62
18.5	¹⁾ M3AA	180 LB	965	90.1	0.81	39	970	90.9	0.78	36.5	0.237	160	59
30	¹⁾ M3AA	200 MLC	980	91.5	0.83	57	985	91.9	0.83	52	0.49	200	63
37	M3AA	225 SMC	980	92.7	0.83	72	985	93.2	0.81	68	0.75	252	63
45	¹⁾ M3AA	250 SMB	985	93.5	0.84	87	985	93.6	0.83	81	1.49	320	63

Recalculation factors

Recalculation factors for current at rated voltages other than 400 V 50 Hz.			
Rated voltage at 50 Hz and motor wound for	Recalculation factor	Rated voltage at 50 Hz and motor wound for	Recalculation factor
220 V	1.82	500 V	0.80
230 V	1.74	660 V	0.61
415 V	0.96	690 V	0.58

General purpose aluminum motors

Technical data for totally enclosed squirrel cage three phase motors

IP 55 – IC 411 – Insulation class F, temperature rise class B

Output kW	Motor type	Product code	Speed r/min	Efficiency		Power factor cos φ 100%	Current		Torque			
				Full load 100%	3/4 load 75%		I _N A	I _s A	T _N Nm	T _s Nm	T _{max} Nm	
750 r/min = 8-poles			400 V 50 Hz				Basic design					
0.055	M2VA 63 B	3GVA 064 002-••A	680	38.3	31.8	0.48	0.45	1.8	0.78	2.1	2.1	
0.09	M2VA 71 A	3GVA 074 001-••C	690	45.8	37.5	0.57	0.52	2.2	1.25	2.3	2.3	
0.12	M2VA 71 B	3GVA 074 002-••C	690	46.4	38.1	0.55	0.69	2.2	1.67	2.5	2.5	
0.18	M2VA 80 A	3GVA 084 001-••B	700	59.9	54.5	0.60	0.75	3.1	2.46	3.2	3.6	
0.25	M2VA 80 B	3GVA 084 002-••B	700	70.7	67.4	0.62	0.85	3.1	3.52	2.9	3.1	
0.37	M3AA 90 S	3GAA 094 001-••E	700	61.5	43.4	0.56	1.6	3.0	5	1.9	2.4	
0.55	M3AA 90 L	3GAA 094 002-••E	690	62.9	56.4	0.57	2.35	3.0	7.5	1.7	2.1	
0.75	M3AA 100 LA	3GAA 104 001-••E	700	72.0	63.6	0.59	2.55	3.5	10	2.1	2.7	
1.1	M3AA 100 LB	3GAA 104 002-••E	700	73.0	68.8	0.64	3.35	3.5	15	2.1	2.7	
1.5	M3AA 112 M	3GAA 114 001-••C	695	74.5	74.6	0.65	4.5	4.1	21	1.9	2.5	
2.2	M3AA 132 S	3GAA 134 001-••C	720	80.5	80.2	0.67	5.9	5.3	29	1.9	2.5	
3	M3AA 132 M	3GAA 134 002-••C	720	82.0	82.0	0.68	7.8	5.5	40	2.4	2.6	
4	M3AA 160 MA	3GAA 164 101-••C	715	84.1	84.7	0.69	10	5.1	53	2.1	2.6	
5.5	M3AA 160 M	3GAA 164 102-••C	710	84.7	85.6	0.70	13.4	5.5	74	2.4	2.6	
7.5	M3AA 160 L	3GAA 164 103-••C	715	86.3	87.3	0.70	18.1	5.4	100	2.4	2.7	
11	M3AA 180 L	3GAA 184 101-••C	720	89.6	90.3	0.76	23.5	5.7	146	2.1	2.5	
15	M3AA 200 MLA	3GAA 204 001-••C	740	91.1	91.6	0.82	29	7.5	196	3.0	3.2	
18.5	M3AA 225 SMA	3GAA 224 001-••C	730	91.1	91.6	0.79	37	6.8	242	2.8	3.1	
22	M3AA 225 SMB	3GAA 224 002-••C	730	91.5	92.2	0.77	45	6.4	287	2.4	2.6	
30	M3AA 250 SMA	3GAA 254 001-••C	735	92.8	93.1	0.79	59	7.3	389	2.2	2.6	
37	M3AA 280 SMA	3GAA 284 001-••C	735	93.0	93.3	0.81	74	7.4	478	2.9	3.1	
750 r/min = 8-poles			400 V 50 Hz				High-output design					
0.18	M2VA 71 C	3GVA 074 003-••C	680	51.3	49.9	0.61	0.8	2.2	2.6	2.5	2.2	
0.37	M2VA 80 C	3GVA 084 003-••B	690	64.6	65.3	0.69	1.2	3.0	5.3	2.3	2.1	
0.75	¹⁾ M3AA 90 LB	3GAA 094 003-••E	680	64.0	60.0	0.65	2.65	3.0	10	1.8	2.0	
1.5	¹⁾ M3AA 100 LC	3GAA 104 003-••E	670	71.0	65.9	0.70	4.4	3.3	21	1.8	2.2	
1.9	¹⁾ M3AA 112 MB	3GAA 114 002-••C	690	74.0	74.8	0.67	5.6	4.3	26.5	2.0	2.6	
3.8	¹⁾ M3AA 132 MB	3GAA 134 003-••C	710	80.5	80.7	0.69	9.9	5.2	51	2.3	2.6	
8.5	¹⁾ M3AA 160 LB	3GAA 164 104-••C	700	85.1	85.7	0.70	21	5.3	114	2.3	2.6	
15	¹⁾ M3AA 180 LB	3GAA 184 102-••C	720	88.7	89.6	0.76	32.5	6.0	199	2.4	2.6	
18.5	M3AA 200 MLB	3GAA 204 002-••C	735	91.4	91.8	0.81	36	7.3	241	2.6	3.1	
30	¹⁾ M3AA 225 SMC	3GAA 224 003-••C	735	91.7	92.3	0.79	64	6.7	391	2.8	3.0	
37	M3AA 250 SMB	3GAA 254 002-••C	735	93.0	93.3	0.81	74	7.4	478	2.9	3.1	

¹⁾ Temperature rise class F.

The bullets in the product code indicate choice of mounting arrangement, voltage and frequency, generation code (see ordering information page).

General purpose aluminum motors

Technical data for totally enclosed squirrel cage three phase motors

IP 55 – IC 411 – Insulation class F, temperature rise class B

Output kW	Motor type	Speed r/min	Efficiency %	Power factor cos φ	Current I _N A	Speed r/min	Efficiency %	Power factor cos φ	Current I _N A	Moment of inertia J=1/4 GD ² kgm ²	Weight kg	Sound pressure level L _p dB(A)
750 r/min = 8-poles		380 V 50 Hz				415 V 50 Hz						
0.055	M2VA 63 B	675	41.2	0.50	0.41	690	35.7	0.44	0.5	0.00027	4.5	36
0.09	M2VA 71 A	680	46.3	0.60	0.5	700	43.8	0.53	0.55	0.00063	5.5	40
0.12	M2VA 71 B	680	47.7	0.59	0.65	700	44.4	0.53	0.7	0.00081	6.5	40
0.18	M2VA 80 A	690	61.1	0.64	0.7	705	57.8	0.57	0.77	0.001842	9	45
0.25	M2VA 80 B	675	70.2	0.66	0.84	690	69.6	0.58	0.87	0.002176	10	45
0.37	M3AA 90 S	690	62.7	0.59	1.57	700	60.5	0.54	1.7	0.0032	13	43
0.55	M3AA 90 L	680	64.9	0.61	2.27	690	61.5	0.55	2.43	0.0043	16	43
0.75	M3AA 100 LA	690	72.0	0.63	2.5	700	71.0	0.55	2.7	0.0069	20	46
1.1	M3AA 100 LB	700	74.0	0.68	3.3	710	73.0	0.60	3.5	0.0082	23	46
1.5	M3AA 112 M	685	74.0	0.69	4.6	700	74.0	0.61	4.7	0.016	28	52
2.2	M3AA 132 S	715	80.0	0.71	5.9	725	80.0	0.65	5.9	0.038	46	56
3	M3AA 132 M	715	82.0	0.72	7.8	720	82.0	0.68	7.7	0.045	53	56
4	M3AA 160 MA	710	83.5	0.71	10.2	720	84.1	0.66	9.9	0.072	75	59
5.5	M3AA 160 M	705	84.0	0.72	13.8	715	85.0	0.68	13.3	0.091	88	59
7.5	M3AA 160 L	710	85.7	0.72	18.6	715	86.6	0.68	17.8	0.131	118	59
11	M3AA 180 L	715	89.0	0.77	24.5	720	89.8	0.75	23	0.224	147	59
15	M3AA 200 MLA	735	91.0	0.83	30	740	91.2	0.79	29	0.45	175	60
18.5	M3AA 225 SMA	730	91.0	0.79	39	735	91.3	0.76	36	0.61	210	63
22	M3AA 225 SMB	730	91.0	0.81	47	735	91.7	0.76	44	0.68	225	63
30	M3AA 250 SMA	735	92.6	0.81	61	740	92.7	0.77	58	1.25	280	63
37	M3AA 280 SMA	735	92.5	0.82	77	735	92.8	0.81	73	1.52	375	63
750 r/min = 8-poles		380 V 50 Hz				415 V 50 Hz						
0.18	M2VA 71 C	670	52.3	0.65	0.8	700	51.4	0.58	0.8	0.0011	7	40
0.37	M2VA 80 C	670	63.1	0.72	1.2	700	65.1	0.66	1.3	0.002576	11	45
0.75	¹⁾ M3AA 90 LB	670	64.0	0.69	2.6	690	63.0	0.61	2.7	0.0048	18	43
1.5	¹⁾ M3AA 100 LC	660	71.0	0.73	4.5	675	70.0	0.65	4.6	0.009	26	46
1.9	¹⁾ M3AA 112 MB	680	73.8	0.71	5.9	695	73.6	0.65	5.8	0.018	33	52
3.8	¹⁾ M3AA 132 MB	705	80.0	0.72	10	715	80.5	0.67	9.9	0.049	59	56
8.5	¹⁾ M3AA 160 LB	695	84.6	0.73	21.5	705	85.3	0.68	20.5	0.131	118	62
15	¹⁾ M3AA 180 LB	715	88.1	0.78	33.5	720	89.1	0.74	32	0.24	155	62
18.5	M3AA 200 MLB	735	91.2	0.83	37	735	91.6	0.79	35	0.54	200	60
30	¹⁾ M3AA 225 SMC	730	91.5	0.80	65	735	91.6	0.77	63	0.8	255	63
37	M3AA 250 SMB	735	92.5	0.82	77	735	92.8	0.81	73	1.52	320	63

Recalculation factors

Recalculation factors for current at rated voltages other than 400 V 50 Hz.			
Rated voltage at 50 Hz and motor wound for	Recalculation factor	Rated voltage at 50 Hz and motor wound for	Recalculation factor
220 V	1.82	500 V	0.80
230 V	1.74	660 V	0.61
415 V	0.96	690 V	0.58

General purpose aluminum motors, premium efficiency

Data acc. to IEC 60034-2, determination of efficiency

IP 55 – IC 411 – Insulation class F, temperature rise class B

Output kW	Motor type	Product code	Speed r/min	Efficiency		Power factor cos φ 100%	Current		Torque			Moment of inertia J=1/4 GD ² kgm ²	Weight kg	Sound pressure level L _p dB(A)	
				Full load 100%	3/4 load 75%		I _N	I _s	T _N	T _s	T _{max}				
3000 r/min = 2 poles															
400 V 50 Hz															
Basic design															
1.5	M3AA	90 L	3GAA 091 312-••C	2900	85.9	86.5	0.87	3	7.7	5	2.7	3.6	0.002	16	63
2.2	M3AA	90 LB	3GAA 091 313-••C	2880	85.8	87.1	0.87	4.4	7.4	7.3	3.0	3.6	0.002	18	63
3	M3AA	100 LB	3GAA 101 312-••C	2920	87.6	87.5	0.86	5.9	10.0	9.9	3.9	4.9	0.005	25	62
4	M3AA	112 M	3GAA 111 022-••C	2860	87.7	89.4	0.93	7.1	7.5	13.4	2.6	3.4	0.012	33	63
5.5	M3AA	132 SA	3GAA 131 023-••C	2900	88.6	88.9	0.88	10.3	9.9	18.1	4.0	4.5	0.016	42	69
7.5	M3AA	132 SB	3GAA 131 024-••C	2915	90.9	91.3	0.90	13.3	11.0	24.6	5.1	5.2	0.022	56	69
11	M3AA	160 MA	3GAA 161 121-••C	2935	91.5	91.9	0.90	19.2	7.4	36	2.7	2.9	0.047	84	69
15	M3AA	160 M	3GAA 161 122-••C	2940	92.3	92.7	0.90	26	8.0	49	3.0	3.3	0.053	94	69
18.5	M3AA	160 L	3GAA 161 123-••C	2935	93.1	93.6	0.89	32.5	8.3	60	3.1	3.3	0.058	100	69
22	M3AA	180 M	3GAA 181 121-••C	2945	93.2	93.8	0.91	37.5	7.1	71	2.7	2.9	0.092	137	70
30	M3AA	200 MLB	3GAA 201 021-••C	2950	93.0	93.3	0.90	52	7.9	97	3.0	2.9	0.18	200	72
37	M3AA	200 MLC	3GAA 201 022-••C	2960	93.9	94.1	0.89	64	8.8	120	3.6	3.3	0.19	205	72
45	M3AA	225 SMC	3GAA 221 021-••C	2970	94.4	94.4	0.88	78	6.9	145	2.3	2.9	0.29	260	74
55	M3AA	250 SMB	3GAA 251 021-••C	2970	94.1	94.1	0.91	93	7.5	177	2.5	3.0	0.57	330	75
75	M3AA	250 SMC	3GAA 251 022-••C	2965	94.8	95.0	0.93	124	7.7	242	2.3	2.8	0.6	345	75
1500 r/min = 4 poles															
400 V 50 Hz															
Basic design															
1.1	M3AA	90 L	3GAA 092 312-••C	1420	83.9	84.3	0.80	2.4	6.1	7.4	2.9	3.4	0.004	16	50
1.5	M3AA	100 LA	3GAA 102 311-••C	1440	85.6	85.5	0.82	3.2	6.9	10	2.8	3.4	0.006	21	54
2.2	M3AA	100 LC	3GAA 102 313-••C	1450	86.8	86.5	0.77	4.8	8.5	14.5	4.0	4.6	0.009	25	54
3	M3AA	112 MA	3GAA 112 021-••C	1455	87.5	87.8	0.81	6.2	7.9	19.7	2.7	3.7	0.018	34	56
4	M3AA	112 M	3GAA 112 022-••C	1455	88.3	88.6	0.76	8.6	8.5	26.3	3.3	4.3	0.018	34	56
5.5	M3AA	132 S	3GAA 132 023-••C	1460	89.3	90.5	0.84	10.6	7.0	36.2	2.2	2.8	0.038	48	59
7.5	M3AA	132 M	3GAA 132 024-••C	1450	90.3	91.0	0.87	14	7.8	49	2.2	3.1	0.048	59	59
11	M3AA	160 M	3GAA 162 121-••C	1470	91.5	92.1	0.83	21	8.1	72	3.4	3.3	0.091	94	62
15	M3AA	160 L	3GAA 162 122-••C	1460	91.3	92.1	0.83	28.5	7.6	98	3.3	3.1	0.102	103	62
18.5	M3AA	180 M	3GAA 182 121-••C	1470	92.5	93.4	0.84	34	6.6	121	2.7	2.8	0.191	141	62
22	M3AA	180 L	3GAA 182 122-••C	1475	93.2	93.9	0.84	41	7.8	143	3.1	3.4	0.225	161	62
30	M3AA	200 MLB	3GAA 202 021-••C	1475	93.7	94.3	0.84	55	8.0	194	4.0	3.1	0.34	205	63
37	M3AA	225 SMB	3GAA 222 021-••C	1480	93.7	94.0	0.85	68	8.1	239	3.9	2.9	0.42	230	66
45	M3AA	225 SMC	3GAA 222 022-••C	1480	94.4	94.8	0.86	80	8.0	291	3.8	3.2	0.49	265	66
55	M3AA	250 SMB	3GAA 252 021-••C	1480	94.5	94.9	0.87	96	7.4	356	3.0	3.1	0.88	335	67
55	M3AA	225 SMD	3GAA 222 023-••C	1480	94.5	94.8	0.86	98	8.5	355	4.3	3.8	0.56	290	66
75	M3AA	250 SMC	3GAA 252 022-••C	1480	95.2	95.6	0.85	135	8.4	484	3.4	5.1	0.95	360	66

The bullets in the product code indicate choice of mounting arrangement, voltage and frequency, generation code (see ordering information page).

General purpose aluminum motors, premium efficiency

Data acc. to IEC 60034-2, determination of efficiency

IP 55 – IC 411 – Insulation class F, temperature rise class B

Output kW	Motor type	Product code	Speed r/min	Efficiency		Power factor cos φ 100%	Current		Torque			Moment of inertia J=1/4 GD ² kgm ²	Weight kg	Sound pressure level L _p dB(A)		
				Full load 100%	3/4 load 75%		I _N A	I _s I _N	T _N Nm	T _s T _N	T _{max} T _N					
1000 r/min = 6 poles																
400 V 50 Hz																
Basic design																
2.2	M3AA	112 M	3GAA 113 022-••C	945	81.8	82.9	0.76	5.1	6.0	22.3	2.4	2.9	0.018	33	54	
3	M3AA	132 S	3GAA 133 024-••C	965	85.2	86.1	0.79	6.4	7.0	29.8	2.2	2.8	0.038	46	61	
4	M3AA	132 MA	3GAA 133 025-••C	960	86.0	87.3	0.80	8.3	7.0	39.8	2.9	2.7	0.045	54	61	
5.5	M3AA	132 MB	3GAA 133 026-••C	960	86.6	87.6	0.78	12	7.3	54	3.5	3.0	0.049	59	61	
7.5	M3AA	160 M	3GAA 163 121-••C	975	89.9	90.6	0.77	15.6	7.8	74	2.4	3.3	0.107	102	59	
11	M3AA	160 L	3GAA 163 122-••C	970	90.3	91.2	0.78	23	7.6	108	2.7	3.4	0.127	117	61	
15	M3AA	180 L	3GAA 183 121-••C	970	91.4	91.9	0.75	31	8.3	147	2.8	3.9	0.237	160	59	
18.5	M3AA	200 MLB	3GAA 203 021-••C	985	91.5	91.6	0.81	36	8.3	180	3.7	3.3	0.43	185		
22	M3AA	200 MLC	3GAA 203 022-••C	985	92.1	92.5	0.82	42	8.3	214	4.0	3.0	0.49	200		
30	M3AA	225 SMC	3GAA 223 021-••C	985	92.8	93.3	0.83	56	7.5	291	3.8	2.8	0.75	252		
37	M3AA	250 SMB	3GAA 253 021-••C	985	93.6	93.9	0.82	69	8.3	358	4.1	2.6	1.49	320		
750 r/min = 8 poles																
400 V 50 Hz																
Basic design																
1.5	M3AA	112 M	3GAA 114 022-••C	695	74.0	75.4	0.69	4.1	4.0	20.8	1.6	2.2	0.018	33		
2.2	M3AA	132 S	3GAA 134 023-••C	720	80.2	80.4	0.67	5.9	5.4	29.2	1.9	2.7	0.045	53		
3	M3AA	132 M	3GAA 134 024-••C	715	80.2	81.0	0.70	7.8	5.2	40.1	2.1	2.5	0.049	59		
4	M3AA	160 MA	3GAA 164 121-••C	720	84.6	85.7	0.69	9.8	5.0	53	2.1	2.5	0.091	88		
5.5	M3AA	160 M	3GAA 164 122-••C	725	86.2	86.6	0.66	14.1	5.8	73	2.4	3.1	0.131	118		
7.5	M3AA	160 L	3GAA 164 123-••C	715	85.9	86.9	0.70	18.2	5.4	100	2.1	2.7	0.131	118		
11	M3AA	180 L	3GAA 184 121-••C	720	87.8	89.2	0.75	24	6.0	147	3.2	2.6				
15	M3AA	200 MLB	3GAA 204 021-••C	735	91.0	91.7	0.81	29	7.9	195	3.2	3.3	0.54	200		
18.5	M3AA	225 SMB	3GAA 224 021-••C	735	91.0	91.8	0.76	38	6.6	241	2.5	3.0	0.68	225		
22	M3AA	225 SMC	3GAA 224 022-••C	735	91.3	91.9	0.75	46	7.1	286	3.0	3.3	0.8	255		
30	M3AA	250 SMB	3GAA 254 021-••C	740	92.6	93.2	0.78	60	7.5	389	2.8	3.3	1.52	320		

¹⁾ On request.

The bullets in the product code indicate choice of mounting arrangement, voltage and frequency, generation code (see ordering information page).

Data at voltage ranges

Rated data at voltage codes S and D



Single-speed motors of size 112 to 132 can be produced with voltage codes S and D, i.e., voltage range at both 50 and 60 Hz. The current rating for each voltage range is specified on the rating plate. It represents the highest current that can exist within the voltage

range at the rated output. The power factor and speed specified on the rating plate apply at the average voltage within the range.

Output in kW		Design ³⁾	Motor type	Product code 3GAA	Current in A ¹⁾ at		Speed in r/min		Power factor cos φ	
50 Hz	60 Hz				380-420 V 50 Hz	440-480 V 60 Hz	380-420 V 50 Hz	440-480 V 60 Hz	380-420 V 50 Hz	440-480 V 60 Hz
3000/3600 r/min = 2 poles										
4	4.6	⁴⁾	M2AA 112 M	111 001-...A	7.8	7.7	2850	3450	0.91	0.91
4	4.6		M3AA 112 M	111 022-...C	7.6	7.4	2860	3460	0.93	0.93
5.5	6.4	²⁾ HO	M3AA 112 MB	111 002-...C	10.5	10.4	2855	3455	0.93	0.93
5.5	6.4	⁴⁾	M2AA 132 SA	131 001-...A	10.9	11	2855	3455	0.88	0.88
5.5	6.4		M3AA 132 SA	131 023-...C	10.7	10.7	2900	3500	0.88	0.87
7.5	8.6	⁴⁾	M2AA 132 SB	131 002-...A	14.7	14.4	2855	3455	0.90	0.90
7.5	8.6		M3AA 132 SB	131 024-...C	13.9	13.8	2915	3515	0.90	0.89
9.2	10.6	²⁾ HO	M3AA 132 SBB	131 004-...C	17.6	17.3	2840	3440	0.92	0.92
11	12.6	²⁾ HO	M3AA 132 SC	131 003-...C	21	20	2835	3445	0.93	0.93
1500/1800 r/min = 4 poles										
3	3.5		M3AA 112 MA	112 021-...C	6.5	6.4	1450	1750	0.81	0.8
4	4.6	⁴⁾	M2AA 112 M	112 001-...A	8.9	8.6	1435	1735	0.80	0.81
4	4.6		M3AA 112 M	112 022-...C	9	8.6	1455	1755	0.76	0.76
5.5	6.4	²⁾ HO	M3AA 112 MB	112 002-...C	11.7	11.6	1425	1725	0.83	0.83
5.5	6.4	⁴⁾	M2AA 132 S	132 001-...A	11.5	11.5	1450	1750	0.83	0.83
5.5	6.4		M3AA 132 S	132 023-...C	11.1	11.1	1460	1760	0.84	0.84
7.5	8.6	⁴⁾	M2AA 132 M	132 002-...A	15.3	15.1	1450	1750	0.83	0.83
7.5	8.6		M3AA 132 M	132 024-...C	14.6	14.3	1450	1750	0.87	0.86
9.2	10.6	²⁾ HO	M3AA 132 MBA	132 004-...C	18.4	18.2	1445	1745	0.87	0.87
11	12.6	²⁾ HO	M3AA 132 MB	132 003-...C	22	22	1450	1750	0.86	0.86

²⁾ Recalculation factors

Multiple by 1.73 when recalculating:

from 380-420 V to 220-240 V 50 Hz

from 440-480 V to 250-280 V 50 Hz

³⁾ Class F temperature rise

⁴⁾ High-output design.

⁵⁾ Efficiency class eff2.

Data at voltage ranges

Rated data at voltage codes S and D

Single-speed motors of size 112 to 132 can be produced with voltage codes S and D, i.e., voltage range at both 50 and 60 Hz. The current rating for each voltage range is specified on the rating plate. It represents the highest current that can exist within the voltage range at

the rated output. The power factor and speed specified on the rating plate apply at the average voltage within the range.

Output in kW		Design ³⁾	Motor type	Product code 3GAA	Current in A ¹⁾ at		Speed in r/min		Power factor cos φ	
50 Hz	60 Hz				380-420 V 50 Hz	440-480 V 60 Hz	380-420 V 50 Hz	440-480 V 60 Hz	380-420 V 50 Hz	440-480 V 60 Hz
1000/1200 r/min = 6 poles										
2.2	2.5		M3AA 112 M	113 001-**C	5.4	5.3	940	1140	0.74	0.74
3.0	3.5	HO	M3AA 112 MB	113 002-**C	7.3	7.3	935	1135	0.76	0.75
3.0	3.5		M3AA 132 S	133 001-**C	7.1	7.0	960	1160	0.75	0.75
4.0	4.6		M3AA 132 MA	133 002-**C	8.9	8.9	960	1160	0.78	0.78
5.5	6.4		M3AA 132 MB	133 003-**C	12.2	12.2	955	1155	0.78	0.78
6.5	7.5	HO	M3AA 132 MC	133 004-**C	15.2	14.9	960	1160	0.75	0.76
750/900 r/min = 8 poles										
1.5	1.7		M3AA 112 M	114 001-**C	4.6	4.4	695	845	0.65	0.65
2.0	2.3	HO	M3AA 112 MB	114 002-**C	6	6	685	835	0.67	0.66
2.2	2.5		M3AA 132 S	134 001-**C	5.9	5.9	720	870	0.67	0.66
3.0	3.5		M3AA 132 M	134 002-**C	7.8	7.8	720	870	0.68	0.68
3.8	4.4	HO	M3AA 132 MB	134 003-**C	10	10	710	860	0.69	0.69

¹⁾ Recalculation factors.

Multiply by 1.73 when recalculating:
 from 380-420 V to 220-240 V 50 Hz
 from 440-480 V to 250-280 V 60 Hz

²⁾ Class F temperature rise.

³⁾ High-output design.

⁴⁾ Efficiency class EFF2.

General purpose aluminum motors

Technical data for totally enclosed squirrel cage three phase motors, two-speed

IP 55 – IC 411 – Insulation class F, temperature rise class F

Output kW	Motor type	Product code	Speed r/min	Efficiency %	Power factor cos φ	Current		Torque			Moment of inertia J=1/4 GD ² kgm ²	Weight kg
						I _N A	I _s / I _N	T _N Nm	T _s / T _N	T _{max} / T _N		
3000/1500 r/min = 2/4 poles			400 V 50 Hz			Fan drive, two separate windings						
0.65/0.14	M3VA 80 A	3GVA 087 121-**-B	2860/1450	73.0/57.0	0.85/0.57	1.5/0.58	4.8/3.6	2.18/0.93	1.9/2	2.2/2.3	0.0008	9
0.95/0.2	M3VA 80 B	3GVA 087 122-**-B	2850/1440	75.0/61.0	0.87/0.69	2.1/0.7	5/3.7	3.19/1.33	2/1.8	2.2/2.2	0.0009	11
1.1/0.25	M3VA 80 C	3GVA 087 123-**-B	2860/1440	77.0/63.0	0.87/0.70	2.4/0.85	5.3/3.8	3.7/1.7	2/1.8	2.2/2	0.0012	12
1.4/0.22	M3AA 90 S	3GAA 098 201-**-E	2870/1470	77.0/48.0	0.87/0.63	3/1.1	5.3/3.3	4.6/1.4	1.7/1	2.4/2.3	0.0019	13
1.9/0.3	M3AA 90 L	3GAA 098 202-**-E	2880/1470	78.0/53.0	0.87/0.68	4/1.1	5.8/3.7	6.3/1.9	1.9/1	2.5/2.3	0.0024	16
2.5/0.4	M3AA 100 L	3GAA 108 201-**-E	2900/1470	80.0/60.0	0.87/0.67	5.2/1.5	6.5/4.1	8.2/2.6	2.1/1	3/2.7	0.0041	21
3.5/0.6	M3AA 112 M	3GAA 118 204-**-C	2895/1470	83.0/68.0	0.92/0.60	6.6/2.1	7/5.8	11.5/3.9	1.7/1.8	2.3/2.8	0.012	32
5.5/1	M3AA 132 S	3GAA 138 207-**-C	2900/1470	84.0/64.0	0.88/0.65	10.8/3.5	7.8/5.7	18.1/6.5	2.4/2	2.9/2.8	0.016	42
7.4/1.2	M3AA 132 M	3GAA 138 208-**-C	2875/1475	85.0/67.0	0.93/0.64	13.5/4.1	7.5/5.9	24.6/7.8	2.1/2	2.6/2.8	0.022	56
13/1.9	M3AA 160 M	3GAA 168 352-**-C	2940/1470	88.5/79.5	0.92/0.79	23/4.4	7.8/6.4	42/12	2.1/2.1	3/2.5	0.054	92
17.5/2.5	M3AA 160 L	3GAA 168 353-**-C	2925/1475	89.0/81.0	0.92/0.77	31/5.8	7.1/6.7	57/16	2/2.5	2.6/2.9	0.057	99
20/2.8	M3AA 180 M	3GAA 188 357-**-C	2930/1465	89.0/77.0	0.90/0.77	36/6.9	6.4/5.8	65/18	2.1/1.9	2.4/2	0.094	132
25/3.6	M3AA 180 L	3GAA 188 358-**-C	2940/1465	90.0/78.0	0.88/0.78	46/8.6	7.5/7.3	81/24	2.6/1.9	2.9/1.9	0.108	152
30/4.1	M3AA 200 MLA	3GAA 208 210-**-C	2945/1480	91.5/85.0	0.89/0.72	54/10	8/7.1	97/26	2.2/2.7	2.8/2.8	0.15	175
38/5.5	M3AA 200 MLB	3GAA 208 211-**-C	2945/1480	92.5/86.5	0.91/0.74	67/13	7.7/6.8	123/35	2.2/2.6	2.6/2.6	0.19	205
43/6	M3AA 225 SMB	3GAA 228 207-**-C	2950/1475	92.5/86.5	0.90/0.78	75/13	7.1/5.8	139/39	2.3/2.7	2.4/2	0.26	235
50/7	M3AA 225 SMC	3GAA 228 208-**-C	2955/1480	93.0/87.5	0.91/0.78	86/15	7.3/6.1	162/45	2.4/2.9	2.4/2.1	0.29	260
70/10	M3AA 250 SMB	3GAA 258 204-**-C	2965/1485	94.0/89.5	0.90/0.76	119/22	9.3/7.1	225/64	2.3/2.5	3.1/2.3	0.57	330
3000/1500 r/min = 2-4 poles			400 V 50 Hz			Fan drive, Dahlander-connection						
0.22/0.044	M3VA 63 A	3GVA 068 121-**-A	2770/1420	65.0/50.0	0.76/0.65	0.65/0.2	3.6/3.5	0.75/0.29	2.1/2.4	2.2/2.5	0.00019	4
0.33/0.07	M3VA 63 B	3GVA 068 122-**-A	2700/1380	53.0/45.0	0.82/0.77	1.1/0.3	2.7/2.7	1.17/0.49	1.6/2	1.7/2.1	0.00026	4.5
0.37/0.08	M3VA 71 A	3GVA 078 121-**-C	2690/1460	64.0/42.0	0.92/0.47	0.9/0.6	3.3/4.3	1.31/0.52	1.8/2.1	1.9/2.2	0.00066	5.5
0.55/0.12	M3VA 71 B	3GVA 078 122-**-C	2700/1470	67.0/55.0	0.91/0.42	1.3/0.75	3.8/3.4	1.94/0.78	1.4/2.2	1.5/2.2	0.00089	6.5
0.65/0.13	M3VA 71 C	3GVA 078 123-**-C	2800/1400	69.0/50.0	0.85/0.44	1.6/0.85	4.1/3.5	2.2/0.88	1.5/2.3	1.6/2.4	0.0011	7
0.85/0.2	M3VA 80 A	3GVA 088 121-**-B	2850/1440	77.0/65.0	0.85/0.64	1.9/0.7	5/4.1	2.86/1.33	2.1/2.3	2.3/2.6	0.0008	9
1.1/0.25	M3VA 80 B	3GVA 088 122-**-B	2855/1450	79.0/68.0	0.84/0.63	2.4/0.85	5.3/4.2	3.7/1.65	2.3/2.5	2.5/2.7	0.0009	11
1.4/0.35	M3VA 80 C	3GVA 088 123-**-B	2845/1440	79.0/70.0	0.85/0.67	3/1.1	5.4/4.4	4.7/2.32	2.3/2.4	2.4/2.6	0.0012	11
1.5/0.33	M3AA 90 S	3GAA 098 101-**-E	2860/1460	77.0/66.0	0.87/0.67	3.3/1.1	5.2/3.9	5/2.1	1.8/1.1	2.4/2.1	0.0019	13
2.2/0.45	M3AA 90 L	3GAA 098 102-**-E	2860/1460	80.0/73.0	0.88/0.65	4.6/1.4	5.9/4.4	7.3/2.9	2.1/1.2	2.6/2.3	0.0024	16
2.5/0.47	M3AA 90 LB	3GAA 098 103-**-E	2860/1460	78.0/75.0	0.88/0.62	5.2/1.5	6.1/4.5	8.3/3.1	2.2/1.4	2.5/2.3	0.0027	18
3/0.6	M3AA 100 L	3GAA 108 101-**-E	2880/1470	81.0/74.0	0.89/0.61	6.2/1.9	6.3/4.8	9.9/3.9	2.2/1.4	2.8/2.8	0.0041	21
4.5/1	M3AA 112 M	3GAA 118 104-**-C	2875/1450	83.0/80.0	0.93/0.76	8.4/2.4	7/6	14.9/6.6	1.8/1.9	2.3/2.8	0.012	32
6.2/1.3	M3AA 132 S	3GAA 138 127-**-C	2880/1455	84.0/80.0	0.91/0.67	11.8/3.5	7/6.5	20.6/8.5	2/2.6	2.6/3.3	0.016	42
8.3/1.7	M3AA 132 M	3GAA 138 108-**-C	2875/1455	84.0/82.0	0.93/0.71	15.4/4.2	7.4/6.6	27.6/11.2	2.5/2.7	2.7/3.3	0.022	56
10/2	M3AA 160 MA	3GAA 168 301-**-C	2910/1465	85.0/83.5	0.89/0.73	19/4.8	5.9/6.1	30/43	1.5/2.4	2.3/2.8	0.039	73
16/3.2	M3AA 160 M	3GAA 168 302-**-C	2915/1465	87.5/86.5	0.92/0.76	28.5/7	6.6/6.3	52/21	1.8/2.5	2.4/2.8	0.054	92
19.5/4.5	M3AA 160 L	3GAA 168 303-**-C	2930/1465	89.0/88.0	0.89/0.77	36/9.7	7.6/6.4	64/29	2.3/2.5	2.9/2.8	0.057	99
21.5/4.7	M3AA 180 M	3GAA 188 305-**-C	2935/1465	90.0/88.0	0.91/0.77	38/10	7/5.3	70/28	2.1/2.1	2.6/2.3	0.094	132
26/5.2	M3AA 180 L	3GAA 188 306-**-C	2940/1470	90.5/89.5	0.89/0.75	47/11	6.9/5.8	85/34	2.3/2.4	2.6/2.4	0.108	152
32/8	M3AA 200 MLA	3GAA 208 110-**-C	2940/1465	90.0/89.5	0.89/0.85	58/16	7.1/6.2	104/52	2/2	2.5/2.2	0.28	180
39/10	M3AA 200 MLB	3GAA 208 111-**-C	2950/1475	91.5/91.0	0.89/0.85	69/19	7.4/6.2	126/65	2/2	2.6/2.3	0.34	205
42/11	M3AA 200 MLC	3GAA 208 112-**-C	2950/1470	92.5/91.0	0.89/0.77	75/23	7.7/5.6	136/71	2.2/2.1	3/2.5	0.19	205
45/13	M3AA 225 SMB	3GAA 228 107-**-C	2955/1475	93.0/91.5	0.92/0.82	76/25	7.4/5.3	145/84	2/2	2.6/2.1	0.27	235
55/15	M3AA 225 SMC	3GAA 228 108-**-C	2955/1475	93.5/92.5	0.91/0.82	94/29	7.3/5.4	178/97	2/2	2.6/2.2	0.3	260
75/25	M3AA 250 SMB	3GAA 258 104-**-C	2965/1475	94.5/93.0	0.92/0.82	125/48	8.9/5.5	241/162	2.3/2	3.1/2.2	0.36	330

Data for motor size 280 on request.

The bullets in the product code indicate choice of mounting arrangement, voltage and frequency, generation code (see ordering information page).

General purpose aluminum motors

Technical data for totally enclosed squirrel cage three phase motors, two-speed

IP 55 – IC 411 – Insulation class F, temperature rise class F

Output kW	Motor type	Product code	Speed r/min	Efficiency %	Power factor cos φ	Current		Torque			Moment of inertia J=1/4 GD ² kgm ²	Weight kg
						I _N A	I _s / I _N	T _N Nm	T _s / T _N	T _{max} / T _N		
1500/750 r/min = 4/8 poles												
400 V 50 Hz												
Fan drive, two separate windings												
0.18/0.025	M3VA 71 A	3GVA 077 241--C	1420/710	50.0/26.0	0.76/0.60	0.7/0.35	2.7/2.1	1.22/0.34	1.5/3.9	1.9/3.9	0.00066	5.5
0.3/0.05	M3VA 71 B	3GVA 077 242--C	1400/700	54.0/34.0	0.80/0.60	1/0.45	2.7/2.1	2.1/0.69	1.5/2.8	1.7/2.8	0.00089	6.5
0.48/0.075	M3VA 80 A	3GVA 087 241--B	1400/710	64.0/35.0	0.79/0.51	1.4/0.55	3.4/2.4	3.3/1	1.7/2.2	1.7/2.6	0.0013	9
0.63/0.1	M3VA 80 B	3GVA 087 242--B	1400/710	68.0/40.0	0.81/0.50	1.65/0.75	3.7/2.5	4.4/1.35	1.8/2.3	1.8/2.6	0.0016	11
0.73/0.12	M3VA 80 C	3GVA 087 243--B	1400/710	70.0/42.0	0.80/0.50	1.9/0.85	4.1/2.6	5/1.7	2/2.3	2/2.5	0.002	12
1/0.13	M3AA 90 S	3GAA 098 207--E	1400/700	71.0/38.0	0.83/0.70	2.6/0.72	3.9/2.1	6.8/1.8	1.5/1	2/1.7	0.0032	13
1.4/0.18	M3AA 90 L	3GAA 098 208--E	1420/710	74.0/41.0	0.81/0.60	3.5/1.1	4.5/2.3	9.4/2.4	1.7/1.1	2.3/2.1	0.0043	16
1.85/0.25	M3AA 100 LA	3GAA 108 206--E	1430/720	78.0/45.0	0.84/0.60	4.2/1.4	4.9/2.5	12/3.3	1.7/1.1	2.3/2.1	0.0069	20
2.3/0.33	M3AA 100 LB	3GAA 108 207--E	1430/720	80.0/49.0	0.86/0.60	5/1.6	5.2/2.6	15/4.3	1.8/1.1	2.4/2.2	0.0082	23
3/0.4	M3AA 112 M	3GAA 118 206--C	1440/730	81.0/51.0	0.87/0.58	6.2/2	6.8/3.8	19.9/5.2	1.5/1.6	2.4/2.6	0.018	32
4/0.6	M3AA 132 S	3GAA 138 231--C	1465/740	84.0/51.0	0.84/0.53	8.2/3.2	6.5/3.5	26.1/7.7	1.5/1.1	2.4/2.5	0.038	48
5.5/0.9	M3AA 132 M	3GAA 138 232--C	1455/735	84.0/53.0	0.87/0.64	10.9/3.9	6.2/3.1	36.1/11.7	1.5/1.1	2.2/2	0.048	59
9/1.3	M3AA 160 M	3GAA 168 356--C	1460/735	87.0/60.0	0.84/0.53	18/5.9	6.6/4	59/17	2/2.2	2.5/2.7	0.089	92
13/1.8	M3AA 160 L	3GAA 168 357--C	1455/735	88.0/64.0	0.85/0.53	26/8.2	6/4.1	89/26	1.9/2.2	2.3/2.6	0.119	117
16/2.3	M3AA 180 M	3GAA 188 361--C	1475/740	88.5/64.0	0.82/0.53	32/9.7	6.8/4.1	104/30	2.2/2.2	2.7/2.6	0.176	130
19/2.7	M3AA 180 L	3GAA 188 362--C	1475/740	89.5/68.0	0.83/0.54	37/10.5	7.5/7.2	123/35	2.6/2.6	2.9/2.6	0.224	159
26/3.3	M3AA 200 MLA	3GAA 208 216--C	1475/740	91.0/73.0	0.85/0.59	49/11	6.9/4.6	168/46	2.1/2.2	2.5/2.3	0.28	180
30/3.8	M3AA 200 MLB	3GAA 208 217--C	1470/740	91.5/75.5	0.86/0.59	55/12.5	6.7/4.6	195/49	2.1/2.2	2.4/2.2	0.34	205
38/5.2	M3AA 225 SMB	3GAA 228 211--C	1480/740	91.5/80.5	0.84/0.63	72/15	7.3/5.2	245/67	2.1/2.3	2.6/2.3	0.41	230
46/7	M3AA 225 SMC	3GAA 228 212--C	1480/740	92.5/82.0	0.86/0.66	85/19	7.7/4.9	297/90	2.3/2.1	2.7/2.1	0.49	265
63/10	M3AA 250 SMB	3GAA 258 206--C	1475/740	93.5/83.0	0.89/0.65	110/27	7.5/6	408/129	2.4/3	2.7/2.7	0.89	335
1500/750 r/min = 4-8 poles												
400 V 50 Hz												
Fan drive, Dahlander-connection												
0.18/0.037	M3VA 71 A	3GVA 078 241--C	1380/720	58.0/17.0	0.74/0.50	0.6/0.7	3.5/1.7	1.24/0.49	1.7/1.7	1.8/1.8	0.00066	5.5
0.37/0.09	M3VA 71 B	3GVA 078 242--C	1360/700	58.0/19.0	0.84/0.52	1.1/1.2	3.1/1.7	2.6/1.2	1.3/1.8	1.4/1.9	0.00089	6.5
0.45/0.1	M3VA 71 C	3GVA 078 243--C	1390/685	60.0/24.0	0.78/0.51	1.4/1.2	3.5/2.6	3.1/1.4	1.7/1.3	1.8/1.4	0.0011	7
0.55/0.13	M3VA 80 A	3GVA 088 241--B	1410/680	64.0/50.0	0.70/0.60	1.8/0.65	3.8/2.4	3.74/1.83	2.2/1.6	2.2/1.6	0.0013	9
0.75/0.17	M3VA 80 B	3GVA 088 242--B	1400/675	67.0/53.0	0.75/0.62	2.15/0.75	4/2.4	5.13/2.41	2/1.4	2/1.4	0.0016	10
0.9/0.2	M3VA 80 C	3GVA 088 243--B	1400/680	70.0/56.0	0.76/0.62	2.45/0.85	4.3/2.5	6.15/2.82	2.3/1.5	2.3/2.5	0.002	11
1.1/0.26	M3AA 90 S	3GAA 098 104--E	1410/700	73.0/53.0	0.80/0.63	2.8/1.2	4.2/2.4	7.4/3.6	1.8/1.2	2.3/1.9	0.0032	13
1.7/0.35	M3AA 90 L	3GAA 098 105--E	1390/700	74.0/57.0	0.82/0.57	4/1.6	4.5/2.5	10.3/4.7	2.2/1.5	2.6/2.1	0.0043	16
1.8/0.35	M3AA 90 LB	3GAA 098 106--E	1400/710	76.0/60.0	0.83/0.56	4.2/1.5	4.3/2.7	12/4.8	1.9/1.6	2.3/2.3	0.0048	18
2.3/0.5	M3AA 100 LA	3GAA 108 103--E	1415/715	76.0/63.0	0.84/0.60	5.2/1.9	4.6/2.7	15.5/6.7	1.8/1.2	2.4/1.9	0.0069	20
2.8/0.6	M3AA 100 LB	3GAA 108 104--E	1430/720	81.0/68.0	0.82/0.58	6.4/2.2	5.2/3	18/8	2/1.2	2.6/2.2	0.0082	23
3/0.65	M3AA 100 LC	3GAA 108 105--E	1430/720	81.0/67.0	0.81/0.56	6.8/2.5	5.6/3	20/8.7	2.2/1.3	2.8/2.3	0.009	26
3.5/0.7	M3AA 112 M	3GAA 118 126--C	1430/720	81.0/71.0	0.89/0.58	7/2.5	6.8/4.4	23.4/9.3	1.6/1.7	2.5/2.7	0.018	32
5/1	M3AA 132 S	3GAA 138 131--C	1450/725	83.0/74.0	0.87/0.59	9.9/3.3	6.4/3.6	32.9/13.2	1.5/1	2.3/2	0.038	48
6.8/1.4	M3AA 132 M	3GAA 138 132--C	1460/730	85.0/73.0	0.84/0.55	13.7/5.1	7.6/3.6	44.5/18.3	2/1.4	2.8/2.7	0.048	59
10.5/2.2	M3AA 160 M	3GAA 168 304--C	1460/735	87.5/79.0	0.84/0.54	21/7.4	6.9/3.7	69/29	2.2/1.5	2.7/2.3	0.089	94
15.5/2.7	M3AA 160 L	3GAA 168 305--C	1460/735	88.5/79.5	0.85/0.51	30/9.5	6.9/3.9	101/35	2.2/1.7	2.6/2.6	0.119	117
17/3.4	M3AA 180 M	3GAA 188 307--C	1470/730	88.5/78.0	0.85/0.56	33/11	5.8/4.3	111/44	1.7/1.2	2.3/1.9	0.176	137
22/4.4	M3AA 180 L	3GAA 188 308--C	1475/735	89.5/79.0	0.83/0.53	43/15	6.7/3.9	143/57	2/1.7	2.6/2.3	0.224	161
29/6.5	M3AA 200 MLA	3GAA 208 116--C	1470/730	90.5/86.0	0.86/0.64	54/17	6.9/4.2	188/81	2.2/1.9	2.4/1.9	0.28	180
33/8	M3AA 200 MLB	3GAA 208 117--C	1475/730	91.5/86.5	0.86/0.64	61/21	7.8/4.2	214/105	2.6/1.9	2.6/1.8	0.34	205
42/10	M3AA 225 SMB	3GAA 228 111--C	1480/740	92.0/89.5	0.86/0.64	85/27	7.8/5	271/129	2.5/2.2	3/2.3	0.49	265
50/11	M3AA 225 SMC	3GAA 228 112--C	1465/735	92.5/89.5	0.87/0.65	91/28	7.3/4.7	324/143	2.3/2	2.5/2	0.49	265
60/15	M3AA 250 SMB	3GAA 258 106--C	1475/735	93.0/90.0	0.86/0.70	104/34	7.9/4.7	388/195	2.6/2.1	2.7/2	0.89	335

General purpose aluminum motors

Technical data for totally enclosed squirrel cage three phase motors, two-speed

IP 55 – IC 411 – Insulation class F, temperature rise class F

Output kW	Motor type	Product code	Speed r/min	Efficiency %	Power factor cos φ	Current		Torque			Moment of inertia J=1/4 GD ² kgm ²	Weight kg
						I _N A	I _s / I _N	T _N Nm	T _s / T _N	T _{max} / T _N		
1500/1000 r/min = 4/6 poles			400 V 50 Hz			Fan drive, two separate windings						
0.18/0.05	M3VA 71 A	3GVA 077 231-**-C	1400/900	56.0/27.0	0.76/0.79	0.6/0.4	3/2.1	1.22/0.53	1.1/1.1	1.2/1.2	0.00066	5.5
0.3/0.1	M3VA 71 B	3GVA 077 232-**-C	1350/900	54.0/30.0	0.86/0.79	0.9/0.6	2.8/2	2.1/1.06	1/1.1	1.1/1.1	0.00089	6.5
0.5/0.19	M3VA 80 A	3GVA 087 231-**-B	1370/930	60.0/53.0	0.84/0.77	1.4/0.7	2.9/3.1	3.5/1.96	1.4/1.5	1.4/1.5	0.0019	9
0.66/0.25	M3VA 80 B	3GVA 087 232-**-B	1390/935	63.0/59.0	0.85/0.78	1.75/0.8	3.3/3.3	4.55/2.56	1.6/1.5	1.6/1.6	0.0022	10
0.78/0.3	M3VA 80 C	3GVA 087 233-**-B	1400/940	66.0/60.0	0.84/0.73	2/1	3.6/3.8	5.33/3.06	1.8/1.9	1.8/2.1	0.0025	10
1/0.3	M3AA 90 S	3GAA 098 204-**-E	1400/940	73.0/53.0	0.83/0.70	2.5/1.2	4.2/2.6	6.8/3	1.8/1	2.2/1.7	0.0032	13
1.5/0.45	M3AA 90 L	3GAA 098 205-**-E	1400/930	72.0/52.0	0.84/0.73	3.5/1.6	4.3/2.9	10/4.5	1.7/1	2.1/1.8	0.0043	16
2/0.6	M3AA 100 LA	3GAA 108 203-**-E	1430/960	77.0/62.0	0.85/0.72	4.5/2	5/3.3	13/5.9	1.8/1	2.4/1.9	0.0069	20
2.5/0.8	M3AA 100 LB	3GAA 108 204-**-E	1430/960	79.0/68.0	0.84/0.71	5.5/2.5	5.6/3.5	16/7.9	2/1.1	2.5/2	0.0082	23
3/1	M3AA 112 M	3GAA 118 205-**-C	1445/975	82.0/67.0	0.84/0.68	6.3/3.1	6/4	19.8/9.8	1.3/1	2.3/2.2	0.018	33
4.5/1.5	M3AA 132 S	3GAA 138 229-**-C	1460/985	83.0/67.0	0.85/0.64	9.2/5.1	6.5/4.2	29.4/14.5	1.5/1	2.3/2.2	0.038	48
6/2	M3AA 132 M	3GAA 138 230-**-C	1460/980	84.0/71.0	0.86/0.73	12/5.6	7.1/4.5	39.2/19.5	1.8/1.3	2.5/2	0.048	59
10.5/3.5	M3AA 160 M	3GAA 168 354-**-C	1460/965	87.0/75.5	0.84/0.78	21/8.6	6.4/4.1	69/35	2/1.3	2.5/1.7	0.089	93
14.5/4.5	M3AA 160 L	3GAA 168 355-**-C	1460/970	88.5/77.0	0.85/0.76	28/11	6.9/4.6	95/44	2.2/1.5	2.6/1.9	0.119	117
16/5	M3AA 180 M	3GAA 188 359-**-C	1470/980	89.0/78.0	0.83/0.73	31/12.5	6.3/4.6	104/49	1.9/1.5	2.5/2	0.176	131
20/6.5	M3AA 180 L	3GAA 188 360-**-C	1470/980	90.0/79.5	0.83/0.74	39/16	7.2/5	130/63	2.4/1.8	2.7/2	0.224	159
23/7.2	M3AA 200 MLA	3GAA 208 213-**-C	1475/985	89.5/84.0	0.88/0.87	43/15	7.7/7.8	149/70	1.6/1.9	2.8/2.9	0.44	175
30/9	M3AA 200 MLB	3GAA 208 214-**-C	1470/990	90.0/86.6	0.90/0.84	54/18.2	7.7/9.5	195/87	1.6/1.7	2.7/2.9	0.53	200
34/11	M3AA 225 SMB	3GAA 228 209-**-C	1470/985	91.0/85.0	0.91/0.89	60/21	7.7/6.7	221/107	1.5/1.3	2.7/2.3	0.67	225
42/14	M3AA 225 SMC	3GAA 228 210-**-C	1475/985	91.5/89.0	0.89/0.89	75/27	8.4/6.8	272/136	1.7/1.4	3/2.3	0.78	255
63/18.5	M3AA 250 SMB	3GAA 258 205-**-C	1475/985	93.5/87.0	0.89/0.79	110/40	7.5/7.3	408/179	2.4/3	2.7/2.6	0.89	335
1000/750 r/min = 6/8 poles			400 V 50 Hz			Fan drive, two separate windings						
0.25/0.1	M3VA 80 A	3GVA 087 341-**-B	945/725	57.0/41.0	0.68/0.55	0.95/0.65	3.2/2.8	2.6/1.32	2/2.4	2.2/2.9	0.0019	9
0.33/0.14	M3VA 80 B	3GVA 087 342-**-B	940/720	62.0/46.0	0.74/0.56	1.05/0.8	3.4/3.1	3.36/1.86	1.9/2.5	1.9/3	0.0022	10
0.45/0.2	M3AA 90 S	3GAA 098 210-**-E	940/700	59.0/44.0	0.72/0.67	1.6/1	3.1/2.2	4.6/2.7	1.4/1	2/1.7	0.0032	13
0.7/0.3	M3AA 90 L	3GAA 098 211-**-E	930/690	63.0/45.0	0.75/0.64	2.2/1.5	3.1/2.3	7.2/4.1	1.3/1.1	1.8/1.8	0.0043	16
0.9/0.4	M3AA 100 LA	3GAA 108 209-**-E	950/720	68.0/55.0	0.77/0.61	2.5/1.8	3.4/2.7	9.1/5.3	1.2/1.1	1.8/1.8	0.0069	20
1.2/0.5	M3AA 100 LB	3GAA 108 210-**-E	950/710	71.0/57.0	0.71/0.61	3.5/2.1	3.7/2.9	12/6.6	1.3/1.2	2/2	0.0082	23
17/7.5	M3AA 200 MLB	3GAA 208 221-**-C	985/740	88.0/81.5	0.85/0.77	33/17	7.1/6.4	165/97	2.2/2.2	2.5/2.5	0.42	185
20/9	M3AA 200 MLC	3GAA 208 222-**-C	985/740	88.5/82.5	0.84/0.74	39/21	7.6/7	194/116	2.4/2.6	2.7/2.9	0.48	200
26/12	M3AA 225 SMB	3GAA 228 215-**-C	985/740	89.5/84.5	0.85/0.76	49/27	7.4/7.1	252/155	2.2/2.4	2.5/2.7	0.63	225
32/14	M3AA 225 SMC	3GAA 228 216-**-C	985/740	90.5/85.5	0.83/0.76	62/31	7/7.2	310/180	2.4/2.5	2.4/2.5	0.74	250
43/15	M3AA 250 SMB	3GAA 258 208-**-C	990/745	91.0/86.0	0.84/0.75	81/34	7.3/7.4	415/198	2.2/2.7	2.5/2.8	1.41	320
1000/500 r/min = 6-12 poles			400 V 50 Hz			Fan drive, Dahlander-connection						
0.4/0.08	M3VA 80 A	3GVA 088 361-**-B	900/460	62.0/30.0	0.78/0.56	1.2/0.7	3.1/1.9	4.26/1.67	1.6/1.6	1.6/1.7	0.0019	9
0.5/0.105	M3VA 80 B	3GVA 088 362-**-B	915/465	66.0/31.0	0.75/0.52	1.45/0.95	3.7/2	5.23/2.16	1.9/1.9	2/2	0.0022	10
0.6/0.12	M3VA 80 C	3GVA 088 363-**-B	920/470	68.0/32.0	0.74/0.50	1.75/1.05	3.8/2.1	6.24/2.45	2/2	2/2	0.0025	11
0.5/0.08	M3AA 90 S	3GAA 098 107-**-E	920/440	60.0/31.0	0.74/0.59	1.7/0.63	2.9/1.7	5.2/1.7	1.2/1.4	1.8/2	0.0032	13
0.75/0.12	M3AA 90 L	3GAA 098 108-**-E	930/450	64.0/36.0	0.73/0.54	2.4/0.9	3/1.8	7.7/2.5	1.3/1.6	1.9/1.9	0.0043	16
0.9/0.16	M3AA 100 LA	3GAA 108 106-**-E	940/470	69.0/45.0	0.73/0.49	2.6/0.96	3.6/2.1	9/3.2	1.3/1.2	2/1.8	0.0069	20
1.3/0.2	M3AA 100 LB	3GAA 108 107-**-E	940/460	71.0/52.0	0.76/0.47	3.5/1.2	3.4/2.2	13/4	1.2/1	1.8/1.5	0.0082	23

Data for motor size 280 on request.

The bullets in the product code indicate choice of mounting arrangement, voltage and frequency, generation code (see ordering information page).

General purpose aluminum motors

Technical data for totally enclosed squirrel cage three phase motors, two-speed

IP 55 – IC 411 – Insulation class F, temperature rise class F

Output kW	Motor type	Product code	Speed r/min	Efficiency %	Power factor cos φ	Current		Torque			Moment of inertia J=1/4 GD ² kgm ²	Weight kg	
						I _N A	I _s / I _N	T _N Nm	T _s / T _N	T _{max} / T _N			
3000/1500 r/min = 2/4 poles													
400 V 50 Hz													
Constant torque, two separate windings													
0.58/0.28	M3VA 80 A	3GVA 089 121--B	2850/1400	70.0/60.0	0.88/0.78	1.35/0.85	4.4/3.1	1.95/1.92	1.6/1.5	1.9/1.5	0.0008	9	
0.7/0.36	M3VA 80 B	3GVA 089 122--B	2860/1400	74.0/64.0	0.88/0.78	1.55/1.05	5/3.4	2.35/2.46	1.8/1.6	2.2/1.8	0.0009	11	
0.85/0.42	M3VA 80 C	3GVA 089 123--B	2890/1410	76.0/66.0	0.87/0.76	1.85/1.25	5.6/3.5	2.82/2.85	1.9/1.7	2.5/1.7	0.0012	12	
1.1/0.55	M3AA 90 S	3GAA 098 213--E	2900/1450	74.0/62.0	0.85/0.64	2.5/2	5.1/3.6	3.6/3.6	1.4/1.5	2.3/2.3	0.0019	13	
1.5/0.75	M3AA 90 L	3GAA 098 214--E	2900/1450	77.0/70.0	0.87/0.67	3.3/2.4	5.7/4.1	4.9/4.9	1.5/1.5	2.5/2.3	0.0024	16	
2/1	M3AA 100 L	3GAA 108 212--E	2900/1460	76.0/67.0	0.89/0.66	4.3/3.3	6.2/4	6.5/6.5	1.9/1.4	2.8/2.6	0.0041	21	
2.6/1.3	M3AA 112 M	3GAA 118 201--C	2900/1460	80.0/75.0	0.92/0.72	5.1/3.5	6.4/5	8.6/8.5	1.6/1.6	2.3/2.3	0.012	32	
4.4/2.2	M3AA 132 SB	3GAA 138 201--C	2925/1450	81.0/74.0	0.86/0.73	9.1/5.9	7.3/4.4	14.4/14.5	2/1.3	2.3/2.2	0.016	42	
5.6/2.8	M3AA 132 M	3GAA 138 202--C	2885/1440	82.0/77.0	0.93/0.75	10.6/7	6.7/5	18.5/18.6	1.8/1.4	2.1/2.2	0.022	56	
12/6	M3AA 160 M	3GAA 168 359--C	2835/1460	87.5/84.5	0.92/0.80	22/13	7.7/6	39/39	2.1/2.3	2.8/2.4	0.054	92	
15/7.5	M3AA 160 L	3GAA 168 360--C	2940/1460	88.5/84.5	0.93/0.78	27/16.5	7.9/6	49/49	2.2/2.4	2.9/2.4	0.057	99	
18/9	M3AA 180 L	3GAA 188 352--C	2945/1460	89.0/84.0	0.90/0.77	32/20	7.7/5.2	58/59	2.5/2.3	2.8/2.1	0.108	152	
23/12	M3AA 200 MLA	3GAA 208 201--C	2960/1475	90.0/89.0	0.89/0.85	42/23	7.8/7.4	74/77	1.7/2.2	2.8/2.5	0.28	178	
30/16	M3AA 200 MLB	3GAA 208 202--C	2960/1475	91.0/90.0	0.90/0.87	53/30	8.2/7.3	97/104	1.8/2.2	2.9/2.5	0.34	204	
36/18	M3AA 225 SMB	3GAA 228 201--C	2960/1480	91.5/91.5	0.91/0.76	63/38	8/7.2	116/116	2.5/3.8	2.7/2.5	0.26	236	
40/20	M3AA 225 SMC	3GAA 228 202--C	2960/1475	92.0/91.5	0.91/0.79	69/41	8.5/6.5	129/129	2.8/3.3	2.8/2.2	0.29	261	
50/25	M3AA 250 SMB	3GAA 258 201--C	2965/1485	93.0/93.0	0.91/0.76	86/52	8.9/8.5	161/161	2.1/3.5	2.9/2.9	0.57	333	
3000/1500 r/min = 2-4 poles													
400 V 50 Hz													
Constant torque, Dahlander-connection													
0.11/0.07	M3VA 56 B	3GVA 050 122--A	2730/1370	53.0/44.0	0.75/0.58	0.4/0.4	3.4/2.6	0.38/0.48	2.5/2.7	2.6/2.8	0.00018	3.5	
0.2/0.15	M3VA 63 A	3GVA 060 121--A	2800/1400	63.0/54.0	0.70/0.63	0.65/0.65	3.6/2.8	0.68/1.02	2.1/2	2.2/2.1	0.00019	4	
0.3/0.2	M3VA 63 B	3GVA 060 122--A	2740/1370	59.0/55.0	0.78/0.63	0.95/0.85	2.8/2.8	1.05/1.4	1.7/2.1	1.8/2.2	0.00026	4.5	
0.37/0.25	M3VA 71 A	3GVA 070 121--C	2700/1390	64.0/60.0	0.89/0.79	0.95/0.7	3.3/3.1	1.3/1.72	1.9/1.5	2/1.6	0.00066	5.5	
0.48/0.31	M3VA 71 B	3GVA 070 122--C	2780/1400	68.0/68.0	0.91/0.76	1.2/0.9	3.6/4	1.66/2.15	1.4/2	1.5/2.1	0.00089	6.5	
0.55/0.37	M3VA 71 C	3GVA 070 123--C	2800/1400	66.0/64.0	0.80/0.65	1.5/1.2	4.7/4.3	1.87/2.52	1.8/1.9	1.9/2	0.0011	7	
0.63/0.5	M3VA 80 A	3GVA 080 121--B	2690/1400	66.0/67.0	0.87/0.79	1.6/1.35	3.6/4.2	2.25/3.42	1.8/1.9	1.9/2.1	0.0013	9	
0.85/0.65	M3VA 80 B	3GVA 080 122--B	2725/1405	70.0/70.0	0.88/0.80	2/1.7	4/4.4	2.99/4.43	1.9/2	1.9/2.2	0.0016	10	
1.1/0.8	M3VA 80 C	3GVA 080 123--B	2730/1410	72.0/71.0	0.88/0.79	2.55/2.05	4.2/4.7	3.8/5.38	2/2	2.1/2.4	0.002	11	
1.3/1	M3AA 90 S	3GAA 098 110--E	2730/1400	71.0/71.0	0.88/0.80	3.1/2.6	3.9/3.8	4.5/6.8	2/1.5	2.2/2	0.0032	13	
1.9/1.5	M3AA 90 L	3GAA 098 111--E	2820/1420	74.0/75.0	0.82/0.76	4.4/3.9	5.1/4.4	6.4/10	2.8/2	3/2.5	0.0043	16	
2.5/2.1	M3AA 100 LA	3GAA 108 109--E	2800/1430	68.0/76.0	0.88/0.81	6/5	4.8/4.4	8.5/14	2.2/1.6	2.5/2.2	0.0069	20	
3.4/2.7	M3AA 100 LB	3GAA 108 110--E	2810/1430	78.0/80.0	0.88/0.85	7.2/5.9	5.3/5.4	11.5/18	2.2/1.9	2.5/2.5	0.0082	23	
4/2.6	M3AA 112 M	3GAA 118 101--C	2865/1430	82.0/77.0	0.94/0.76	7.6/6.5	6.3/6.2	13.3/17.4	1.8/2.3	2.1/2.6	0.012	32	
4.7/3.1	M3AA 132 SB	3GAA 138 101--C	2820/1420	79.0/77.0	0.93/0.76	9.2/7.7	5.5/5.7	15.9/20.8	1.8/2.2	2.1/2.4	0.016	42	
7.2/4.8	M3AA 132 M	3GAA 138 102--C	2870/1435	84.0/81.0	0.93/0.76	13.3/11.5	7.1/6.2	24/31.9	2.4/2.5	2.6/2.7	0.022	56	
9/6.5	M3AA 160 MA	3GAA 168 306--C	2885/1440	83.0/82.0	0.92/0.74	17.1/15.6	4.6/4.3	40/43	1.3/1.7	1.9/1.9	0.039	73	
12.5/9	M3AA 160 M	3GAA 168 307--C	2890/1440	85.5/85.5	0.93/0.80	22.5/19	5.2/4.6	41/60	1.4/1.8	1.9/1.9	0.054	92	
15/10.5	M3AA 160 L	3GAA 168 308--C	2900/1445	87.0/86.0	0.93/0.77	27/23	5.8/4.9	49/69	1.6/2.1	2.1/2.1	0.057	99	
18/12	M3AA 180 M	3GAA 188 301--C	2940/1455	89.0/89.0	0.88/0.79	33/25	6.8/5.3	59/79	2.1/2.4	2.6/2.2	0.094	132	
24/17	M3AA 180 L	3GAA 188 302--C	2945/1455	90.0/90.0	0.89/0.80	43/34	7.4/5.2	78/111	2.4/2.4	2.8/2.1	0.108	152	
32/24	M3AA 200 MLA	3GAA 208 101--C	2940/1470	89.0/90.5	0.89/0.86	58/45	6.8/5.9	104/156	1.8/2.1	2.4/2.1	0.28	180	
39/29	M3AA 200 MLB	3GAA 208 102--C	2950/1470	90.5/91.0	0.84/0.86	75/53	6.8/7	126/188	1.7/2.2	2.6/2.4	0.34	205	
42/32	M3AA 225 SMB	3GAA 228 101--C	2955/1475	92.5/93.0	0.92/0.88	71/57	7.1/6.5	136/207	1.5/1.9	2.5/2.3	0.49	230	
50/40	M3AA 225 SMC	3GAA 228 102--C	2965/1480	92.5/93.0	0.84/0.87	87/72	7.4/7.1	161/259	2.4/2.8	3.3/3	0.49	265	
68/50	M3AA 250 SMB	3GAA 258 101--C	2940/1475	93.0/93.5	0.93/0.88	113/87	6.6/6.9	220/324	1.5/2.1	2.4/2.5	0.89	335	

2

General purpose aluminum motors

Technical data for totally enclosed squirrel cage three phase motors, two-speed

IP 55 – IC 411 – Insulation class F, temperature rise class F

Output kW	Motor type	Product code	Speed r/min	Efficiency %	Power factor cos φ	Current		Torque			Moment of inertia J=1/4 GD ² kgm ²	Weight kg
						I _N A	I _s / I _N	T _N Nm	T _s / T _N	T _{max} / T _N		
3000/750 r/min = 2/8 poles			400 V 50 Hz			Constant torque, two separate windings						
0.25/0.06	M3VA 71 A	3GVA 079 141-**-A	2760/660	52.0/36.0	0.94/0.70	0.75/0.35	2.9/1.9	0.86/0.86	1/1.3	1.1/1.4	0.00066	5.5
0.37/0.09	M3VA 71 B	3GVA 079 142-**-A	2800/660	68.0/41.0	0.87/0.65	0.9/0.5	2.8/2	1.26/1.3	1/1.6	1.1/1.7	0.00089	6.5
0.5/0.12	M3VA 80 A	3GVA 089 141-**-B	2730/700	60.0/38.0	0.87/0.58	1.4/0.8	3.2/2.3	1.78/1.64	1.3/2	1.6/2	0.0013	9
0.66/0.15	M3VA 80 B	3GVA 089 142-**-B	2780/700	65.0/40.0	0.87/0.58	1.65/0.95	3.8/2.5	2.55/2.45	1.4/2.2	1.8/2.2	0.0016	10
0.78/0.18	M3VA 80 C	3GVA 089 143-**-B	2800/700	68.0/43.0	0.87/0.57	1.9/1.15	4/2.6	2.67/2.46	1.5/2.4	2.2/2.4	0.002	11
0.75/0.18	M3AA 90 LA	3GAA 098 700-**-E	2875/720	71.2/46.3	0.80/0.51	1.9/1.1	5.7/2.4	2.5/2.4	2.3/1.3	2.7/1.9	0.0043	16
1.3/0.33	M3AA 90 LB	3GAA 098 701-**-E	2780/690	71.0/52.0	0.92/0.62	2.9/1.5	4.5/2.3	4.4/4.5	1.8/1.2	2/1.7	0.0043	16
1.8/0.5	M3AA 100 LB	3GAA 108 700-**-E	2860/705	80.0/54.0	0.93/0.64	3.5/2.1	5.3/2.6	6/6.7	1.7/1.3	2.2/1.9	0.0082	24
1500/1000 r/min = 4/6 poles			400 V 50 Hz			Constant torque, two separate windings						
0.11/0.08	M3VA 63 B	3GVA 069232-**-A	1390/860	40.0/25.0	0.70/0.72	0.55/0.62	2.5/1.8	0.75/0.88	1.4/1.8	1.9/1.9	0.00026	4.5
0.3/0.2	M3VA 71 A	3GVA 079 231-**-C	1390/900	51.0/40.0	0.82/0.72	0.7/0.5	2.8/2	1.37/0.79	1.1/1.05	1.1/1.1	0.00066	5.5
0.37/0.22	M3VA 71 B	3GVA 079 232-**-C	1380/900	58.0/40.0	0.83/0.80	0.9/0.8	2.7/1.9	2.07/1.91	1/1.1	1.1/1.1	0.00089	6.5
0.43/0.28	M3VA 80 A	3GVA 089 231-**-B	1380/910	60.0/54.0	0.85/0.81	1.4/1.2	3.1/2.9	2.54/3.02	1.5/1.4	1.5/1.4	0.0019	9
0.58/0.37	M3VA 80 B	3GVA 089 232-**-B	1390/920	63.0/58.0	0.85/0.80	1.6/1.15	3.3/3.2	4/3.85	1.5/1.5	1.6/1.6	0.0022	10
0.7/0.45	M3VA 80 C	3GVA 089 233-**-B	1390/925	65.0/60.0	0.85/0.78	1.85/1.4	3.4/3.4	4.82/4.66	1.6/1.7	1.7/1.8	0.0025	10
0.8/0.5	M3AA 90 S	3GAA 098 216-**-E	1430/940	68.0/57.0	0.80/0.66	2.2/2	3.9/2.8	5.3/5	1.5/1.4	2.1/2.1	0.0032	13
1.2/0.75	M3AA 90 L	3GAA 098 217-**-E	1430/940	73.0/63.0	0.81/0.67	3/2.6	4.4/3.1	8/7.6	1.7/1.5	2.3/2.1	0.0043	16
1.5/0.9	M3AA 100 LA	3GAA 108 214-**-E	1440/960	75.0/69.0	0.84/0.65	3.5/3	4.7/3.8	9.9/8.9	1.5/1.5	2.2/2.4	0.0069	20
1.8/1.1	M3AA 100 LB	3GAA 108 215-**-E	1460/960	77.0/70.0	0.78/0.64	4.4/3.6	5.8/3.9	11/11	2.1/1.6	3/2.5	0.0082	23
2.6/1.7	M3AA 112 M	3GAA 118 202-**-C	1445/960	80.0/73.0	0.86/0.76	5.5/4.4	5.9/5.2	17.2/16.9	1.5/1.5	2.2/2.4	0.018	33
3.3/2.2	M3AA 132 S	3GAA 138 223-**-C	1470/980	82.0/76.0	0.82/0.65	7.1/6.4	6.8/4.6	21.4/21.4	1.4/1.2	2.5/2.4	0.038	48
4.5/3	M3AA 132 M	3GAA 138 224-**-C	1470/980	82.0/77.0	0.85/0.70	9.3/8	7.2/5.6	29.2/29.2	1.4/1.5	2.3/2.6	0.048	59
7.5/5.5	M3AA 160 M	3GAA 168 361-**-C	1465/965	85.5/80.5	0.83/0.77	15.5/13	7.1/4.7	49/54	2.1/1.8	2.7/1.9	0.089	93
11.5/8.5	M3AA 160 L	3GAA 168 362-**-C	1465/965	86.5/82.5	0.84/0.76	23/19.5	7/4.9	75/84	2.1/1.8	2.8/2	0.119	117
13/8	M3AA 180 M	3GAA 188 353-**-C	1475/975	88.0/82.5	0.82/0.75	26/19	6.5/4.3	84/78	1.9/1.4	2.6/1.8	0.176	131
15/10	M3AA 180 L	3GAA 188 354-**-C	1475/975	88.5/84.0	0.83/0.74	30/23	7.1/4.4	97/98	2.3/1.5	2.7/1.9	0.224	159
18/12	M3AA 200 MLA	3GAA 208 204-**-C	1475/985	88.5/86.0	0.91/0.86	33/24	7.6/7.8	117/116	2.1/2.6	2.5/2.6	0.42	185
22/14.7	M3AA 200 MLB	3GAA 208 205-**-C	1480/985	89.5/86.5	0.89/0.87	40/29	8.2/7.6	142/143	2.4/2.6	2.8/2.5	0.48	200
25/16.7	M3AA 200 MLC	3GAA 208 206-**-C	1475/980	89.0/85.5	0.87/0.88	47/32	7.7/6.7	162/162	2.3/2.3	2.6/2.2	0.48	200
32/21	M3AA 225 SMB	3GAA 228 203-**-C	1480/985	90.0/89.5	0.88/0.86	58/40	8.6/8	206/204	2.3/2.4	2.8/2.7	0.63	225
36/24	M3AA 225 SMC	3GAA 228 204-**-C	1480/985	90.5/90.0	0.88/0.87	66/45	8.4/7.4	232/233	2.2/2.2	2.8/2.5	0.74	250
50/32	M3AA 250 SMB	3GAA 258 202-**-C	1475/985	92.5/90.5	0.89/0.80	89/65	7.5/7.1	324/310	2.3/3.1	2.6/2.6	0.89	335

Data for motor size 280 on request.

The bullets in the product code indicate choice of mounting arrangement, voltage and frequency, generation code (see ordering information page).

General purpose aluminum motors

Technical data for totally enclosed squirrel cage three phase motors, two-speed

IP 55 – IC 411 – Insulation class F, temperature rise class F

Output kW	Motor type	Product code	Speed r/min	Efficiency %	Power factor cos φ	Current		Torque			Moment of inertia J=1/4 GD ² kgm ²	Weight kg
						I _N A	I _s / I _N	T _N Nm	T _s / T _N	T _{max} / T _N		
1500/750 r/min = 4/8 poles 400 V 50 Hz Constant torque, two separate windings												
0.28/0.14	M3VA 80 A	3GVA 089 241--B	1425/700	60.0/50.0	0.77/0.68	0.9/0.6	4/3	1.88/1.92	1.9/1.9	2.2/2	0.0019	9
0.38/0.19	M3VA 80 B	3GVA 089 242--B	1430/705	64.0/52.0	0.77/0.68	1.1/0.8	4.2/3.1	2.55/2.58	2/2	2.4/2	0.0022	10
0.46/0.23	M3VA 80 C	3GVA 089 243--B	1430/710	66.0/55.0	0.78/0.65	1.3/0.95	4.3/3.3	3.1/3.1	2/2.1	2.4/2.2	0.0025	11
0.55/0.25	M3AA 90 S	3GAA 098 219--E	1450/700	62.0/51.0	0.78/0.59	1.9/1.2	4.2/2.3	3.6/3.4	1.3/1.4	2.2/2.1	0.0032	13
0.75/0.37	M3AA 90 L	3GAA 098 220--E	1450/700	66.0/57.0	0.75/0.57	2.2/1.7	4.1/2.5	4.9/5	1.4/1.5	2.4/2.2	0.0043	16
1.1/0.55	M3AA 100 LA	3GAA 108 217--E	1460/710	68.0/62.0	0.77/0.61	3.1/2.2	4.2/2.6	7.2/7.4	1.2/1.2	2.3/1.9	0.0069	20
1.5/0.75	M3AA 100 LB	3GAA 108 218--E	1440/700	72.0/60.0	0.82/0.60	3.7/2.9	4.6/2.7	9.8/10	1.3/1.2	2.2/1.9	0.0082	23
1.8/0.9	M3AA 112 M	3GAA 118 203--C	1470/715	77.0/65.0	0.76/0.66	4.4/3	6.5/4	11.7/12	1.2/1.6	2.2/2.4	0.018	32
2.5/1.3	M3AA 132 S	3GAA 138 225--C	1470/730	80.0/69.0	0.79/0.58	5.7/4.7	6.7/4.4	16.2/17	1.6/1.4	2.6/2.7	0.038	48
3.3/1.7	M3AA 132 M	3GAA 138 226--C	1470/725	81.0/71.0	0.83/0.67	7.1/5.2	8/4.8	21.4/22.4	1.8/1.8	2.7/2.2	0.048	59
5.5/2.7	M3AA 160 M	3GAA 168 363--C	1465/730	85.0/71.0	0.83/0.57	11.5/9.6	5.6/4	36/35	1.7/2	2.2/2.3	0.089	92
9/4.5	M3AA 160 L	3GAA 168 364--C	1465/730	86.5/73.5	0.83/0.56	18/16	7/4.1	59/59	2.1/2.1	2.7/2.5	0.119	117
14/7	M3AA 180 L	3GAA 188 356--C	1475/735	88.0/76.0	0.83/0.56	28/24	7.7/4.2	91/91	2.6/2.3	2.9/2.3	0.225	159
18.5/9.4	M3AA 200 MLA	3GAA 208 207--C	1475/730	89.5/82.5	0.85/0.65	35/26	7.3/4.3	120/123	2.2/1.9	2.5/1.8	0.28	180
22/11	M3AA 200 MLB	3GAA 208 208--C	1480/735	90.5/83.0	0.84/0.60	42/32	8.4/4.7	142/143	2.6/2.4	2.9/2.2	0.34	205
28/14	M3AA 225 SMB	3GAA 228 205--C	1480/735	90.0/85.5	0.85/0.61	53/39	7.7/4.9	181/182	2.1/2.4	2.7/2.2	0.41	230
34/17	M3AA 225 SMC	3GAA 228 206--C	1480/735	92.0/87.0	0.86/0.66	63/43	7.9/4.8	219/221	2.2/2.2	2.7/2	0.49	265
50/25	M3AA 250 SMB	3GAA 258 203--C	1480/740	92.5/88.0	0.87/0.60	90/68	8.6/6	323/323	2.6/3.5	3/2.9	0.89	335
1500/750 r/min = 4-8 poles 400 V 50 Hz Constant torque, Dahlander-connection												
0.11/0.06	M3VA 63 B	3GVA 060 242--A	1390/660	54.0/33.0	0.60/0.49	0.5/0.55	3/1.7	0.75/0.87	1.6/2.5	1.7/2.6	0.00026	4.5
0.18/0.11	M3VA 71 A	3GVA 070 241--C	1380/680	54.0/37.0	0.70/0.53	0.7/0.8	3.2/2.5	1.24/1.54	1.9/2.2	2/2.3	0.00066	5.5
0.30/0.15	M3VA 71 B	3GVA 070 242--C	1400/700	60.0/47.0	0.74/0.51	0.9/0.9	3.2/2.6	2.05/2.05	2/2.5	2.1/2.6	0.00089	6.5
0.45/0.25	M3VA 80 A	3GVA 080 241--B	1380/700	65.0/48.0	0.87/0.58	1.15/1.3	3.5/2.7	3.12/3.42	1.7/2.1	1.7/2.1	0.0019	9
0.63/0.33	M3VA 80 B	3GVA 080 242--B	1380/705	67.0/50.0	0.88/0.56	1.55/1.7	3.5/2.8	4.37/4.48	1.7/2.2	1.7/2.2	0.0022	10
0.75/0.37	M3VA 80 C	3GVA 080 243--B	1390/710	70.0/52.0	0.86/0.51	1.8/2	3.9/2.9	5.16/4.98	1.9/2.5	1.9/2.5	0.0025	10
0.7/0.37	M3AA 90 S	3GAA 098 113--E	1420/700	72.0/50.0	0.80/0.57	1.8/1.9	4.4/2.3	4.7/5.1	1.6/1.6	2.3/2.2	0.0032	13
1.1/0.55	M3AA 90 L	3GAA 098 114--E	1390/685	70.0/55.0	0.84/0.58	2.6/2.6	4.1/2.3	7.4/7.5	1.4/1.5	2/2.1	0.0043	16
1.5/0.75	M3AA 100 LA	3GAA 108 112--E	1440/710	76.0/62.0	0.85/0.57	3.4/3.2	4.6/2.8	10/10	1.4/1.5	2.2/2.2	0.0069	20
2/0.95	M3AA 100 LB	3GAA 108 113--E	1440/710	78.0/64.0	0.86/0.55	4.4/4	4.8/2.9	13/12	1.4/1.6	2.2/2.3	0.0082	23
2.5/1.5	M3AA 112 M	3GAA 118 103--C	1410/705	78.0/67.0	0.90/0.66	5.1/4.9	5.5/4.1	16.9/20.3	1.4/1.5	2.1/2.4	0.018	32
3.8/1.9	M3AA 132 S	3GAA 138 125--C	1450/730	82.0/70.0	0.86/0.52	7.7/7.6	5.6/3.7	25/24.9	1.4/1.3	2.1/2.7	0.038	48
5/2.5	M3AA 132 M	3GAA 138 126--C	1455/730	85.0/73.0	0.88/0.52	9.6/9.6	6.9/4.8	32.8/32.7	1.7/2	2.4/2.8	0.048	59
8/4.5	M3AA 160 M	3GAA 168 309--C	1440/730	84.5/79.5	0.86/0.60	16/13.5	4.5/3.4	53/59	1.3/1.4	1.8/1.9	0.089	92
12/7	M3AA 160 L	3GAA 168 310--C	1445/730	86.5/81.0	0.87/0.59	23/21	5/3.5	79/92	1.5/1.4	1.9/1.9	0.119	117
16/8	M3AA 180 L	3GAA 188 304--C	1460/730	88.0/78.5	0.86/0.53	31/28	1.9/3.4	105/104	1.4/1.6	1.9/2.1	0.224	159
22/13	M3AA 200 MLA	3GAA 208 107--C	1475/735	87.5/86.0	0.81/0.69	45/32	6.5/5.9	142/169	2/2.5	2.6/2.7	0.36	165
25/15	M3AA 200 MLB	3GAA 208 108--C	1475/735	89.0/86.0	0.86/0.67	47/38	7.6/6	162/195	2.2/2.6	2.7/2.7	0.42	185
29/17	M3AA 200 MLC	3GAA 208 109--C	1475/735	90.0/88.0	0.91/0.75	52/38	7.2/6.1	188/221	2.2/2.6	2.4/2.4	0.48	200
35/21	M3AA 225 SMB	3GAA 228 105--C	1475/735	90.0/89.0	0.90/0.74	63/47	6.7/5.8	227/273	1.7/2.1	2.2/2.3	0.63	225
42/25	M3AA 225 SMC	3GAA 228 106--C	1475/735	91.0/89.5	0.91/0.75	74/54	6.8/5.9	272/325	1.8/2.1	2.2/2.2	0.74	250
55/33	M3AA 250 SMB	3GAA 258 103--C	1480/740	92.0/90.5	0.90/0.75	97/71	7.3/6.4	355/426	2.1/2.5	2.5/2.5	1.5	320
1000/750 r/min = 6/8 poles 400 V 50 Hz Constant torque, two separate windings												
1.6/0.8	M3AA 112 M	3GAA 118 207--C	965/725	72.9/60.0	0.70/0.64	4.5/3	5.6/4.4	15.8/10.6	2.3/2.3	2.6/2.4	0.015	35
2.3/1.3	M3AA 132 S	3GAA 138 213--C	975/730	77.2/63.5	0.72/0.64	6.8/4.6	6.4/4.2	25.4/17	1.6/1.5	2.8/2.3	0.04	48
3.5/1.6	M3AA 132 M	3GAA 138 214--C	975/730	78.8/65.8	0.72/0.66	9/5.2	7.1/5.1	34.2/20.9	2/1.9	2.9/2.4	0.041	48
16/12	M3AA 200 MLB	3GAA 208 219--C	985/740	86.5/82.5	0.85/0.73	31/29	7/6.3	155/155	2.1/2.4	2.4/2.6	0.42	185
18/13.5	M3AA 200 MLC	3GAA 208 220--C	985/740	87.5/83.5	0.83/0.72	36/32	7.9/6.6	174/174	2.5/2.6	2.8/2.8	0.48	200
23/17	M3AA 225 SMB	3GAA 228 213--C	985/740	89.0/85.5	0.84/0.78	46/37	7.9/6.3	222/220	2.3/2.2	2.7/2.3	0.63	225
28/20	M3AA 225 SMC	3GAA 228 214--C	985/740	89.0/86.5	0.86/0.77	57/43	7.1/6.5	272/259	2/2.3	2.4/2.4	0.74	250
37/27	M3AA 250 SMB	3GAA 258 207--C	990/740	90.0/87.5	0.83/0.75	71/59	7.8/6.7	357/348	2.3/2.5	2.7/2.5	1.41	320

General purpose aluminum motors - Variant codes

Code	Variant	Motor size			M2AA	M2AA	M2AA	M3AA	M3AA	M3AA	M3AA
		56-63	71-80	90-100	112-132	160-200	225-250	112-132	160-180	200-250	280
Balancing											
052	Vibration acc. to Grade A (IEC 60034-14).	P	P	P	P	P	P	P	P	P	P
417	Vibration acc. to Grade B (IEC 60034-14).	NA	NA	NA	R	R	R	R	R	R	R
423	Balancing without key.	P	P	P	R	R	R	R	R	R	R
424	Full key balancing.	P	P	P	P	P	P	P	P	P	P
Bearings and lubrication											
036	Transport lock for bearings.	NA	NA	M	M	M	M	M	M	M	M
037	Roller bearing at D-end. Transport lock included.	NA	NA	M	NA	M	M	NA	M	M	M
039	Cold resistant grease. For ambient temperatures -40 - +100° C.	M	M	M	M	M	M	M	M	M	M
040	Heat resistant grease. For bearing temperatures -40 - +160° C. Mandatory for ambient temperatures >50° C.	M	M	M	S	S	S	S	S	S	S
041	Bearings regreasable via grease nipples.	NA	NA	M	M	M	S	M	M	S	S
042	Locked drive-end. Standard for sizes 90-132, flanged versions.	NA	M	S	M	S	S	M	S	S	S
043	SPM nipples.	NA	NA	R	M	M	M	M	M	M	M
057	2RS bearings at both ends. Grease for bearing temperatures -20 - +110° C.	M	M	M	M	R	R	M	M	M	M
058	Angular contact ball bearing at D-end, shaft force away from bearing. Transport lock included.	NA	NA	M	M	R	R	M	M	M	M
059	Angular contact ball bearing at N-end, shaft force towards bearing. Transport lock included.	NA	NA	M	M	R	R	M	M	M	M
107	Bearing mounted PT100 resistance elements.	NA	NA	NA	NA	NA	NA	NA	R	R	R
188	63-series bearings.	NA	NA	M	M	S	S	M	S	S	S
796	Grease nipples JIS B 1575 PT 1/8 Type A. Stainless steel.	NA	NA	NA	M	M	M	M	M	M	M
797	Stainless steel SMP nipples.	NA	NA	NA	M	M	M	M	M	M	M
798	Stainless steel grease nipples.	NA	NA	NA	M	M	M	M	M	M	M
Branch standard designs											
071	Cooling tower duty. Only motors with shaft extensions downwards.	NA	NA	NA	P	P	P	P	P	P	P
079	Silumin-alloy rotor cage.	NA	P	P	R	R	R	R	R	R	R
142	"Manilla" winding connection. (440 VD series, 220 VD parallel, 60Hz) Single speed motors only.	NA	NA	P	P	P	P	P	P	P	P
178	Stainless steel/acid proof bolts.	M	M	M	M	M	M	M	M	M	M
199	Extreme heavy duty design. Type designation M2AP or M3AP.	NA	NA	NA	M	NA	NA	M	M	M	M
209	Non-standard voltage or frequency (special winding).	P	P	P	P	P	P	P	P	P	P
416	High speed design.	NA	NA	NA	R	R	R	R	R	R	R
425	Corrosion protected stator and rotor core.	P	P	P	P	R	R	P	P	P	P
785	Reinforced tropicalisation.	NA	NA	NA	R	R	R	R	R	R	R
Cooling system											
053	Metal fan cover. The dimension L1 and L2 respectively is increased by 7.5 mm for the frame size 112 and 5.5 mm for the frame size 132.	S	S	S	M	S	S	M	S	S	S
068	Metal fan. Mandatory for ambient temperatures: For sizes 71-100, ≥ 80 °C; sizes 112-132, > 50 °C; sizes 160-250, > 80 °C	NA	M	M	M	M	M	M	M	M	M
075	Cooling method IC418 (without fan).	P	P	P	R	R	R	R	R	R	R
183	Separate motor cooling (fan axial, N-end).	NA	M	R	NA	R	R	NA	M	M	M
189	Separate motor cooling, IP44, 400V, 50Hz (fan axial, N-end)	NA	NA	NA	M	M	M	M	M	M	M

¹⁾ Certain variant codes cannot be used simultaneously.

S = Included as standard.

M = On modification of a stocked motor, or on new manufacture, the number per order may be limited.

P = New manufacture only.

R = On request.

NA = Not applicable.

Code	Variant	Motor size			M2AA	M2AA	M2AA	M3AA	M3AA	M3AA	M3AA
		56-63	71-80	90-100	112-132	160-200	225-250	112-132	160-180	200-250	280
1)											
793	Fan for reduced noise level (2-p fan).	NA	NA	NA	R	R	R	R	R	R	R
794	Fan for reduced noise level (4-p fan).	NA	NA	NA	R	R	R	R	R	R	R
Coupling											
035	Assembly of customer supplied coupling-half.	NA	NA	NA	R	R	R	R	R	R	R
Dimension drawing											
141	Binding dimension drawing	M	M	M	M	M	M	M	M	M	M
Drain holes											
065	Plugged drain holes.	M	M	M	M	M	M	M	M	M	M
066	Modified drain hole position. IP 54 for sizes 63-100. Specify IM designation.	M	M	M	M	M	M	M	M	M	M
076	Drain holes with plugs. Holes are sealed with a felt plug. Corrosion protected rotor. IP 55. IM designation must be stated.	S	S	NA	NA	NA	NA	NA	NA	NA	NA
Earthing bolt											
067	External earthing bolt. Earthing screw for connection of external protective earth.	M	M	M	M	M	M	M	M	M	M
Hazardous environments											
See catalogue 'Motors for Hazardous Environments' for details.											
Heating elements											
Motor size		Element capacity									
56-71		8 W									
80-160		25 W									
180-280		50 W									
450	Heating element 100-120 V.	M	M	M	M	M	M	M	M	M	M
451	Heating element 200-240 V.	M	M	M	M	M	M	M	M	M	M
Insulation systems											
014	Winding insulation class H.	P	P	P	P	P	P	P	P	P	P
405	Special winding insulation for frequency converter supply rated voltage >500 V.	NA	NA	R	P	R	R	P	P	P	P
406	Winding for supply > 690 ≥ 1000 V.	NA	NA	NA	NA	NA	NA	R	R	P	P
Marine Motors											
See catalogue "Marine Motors" for details.											
Mounting arrangements											
NOTE: Multiple flange sizes available using two-piece flange system, see page 48.											
007	IM 3001 flange mounted, IEC flange, from IM 1001 (B5 from B3). Large flange with clearance holes.	NA	M	M	NA	R	M	NA	NA	M	M
008	IM 2101 foot/flange mounted, IEC flange, from IM 1001 (B34 from B3). Small flange with tapped holes. Frame size 180 not available.	NA	M	M	M	R	NA	M	R	NA	NA
009	IM 2001 foot/flange mounted, IEC flange, from IM 1001 (B35 from B3). Large flange with clearance holes.	M	M	M	M	M	M	M	M	M	M
047	IM 3601 flange mounted, IEC flange, from IM 3001 (B14 from B5), flange mounted motor with large flange. Small flange with tapped holes. Frame size 180 not available.	M	M	M	M	R	NA	M	R	NA	NA
048	IM 3001 flange mounted, IEC flange, from IM 3601 (B5 from B14), flange mounted motor with small flange. Large flange with clearance holes.	M	M	M	M	NA	NA	M	NA	NA	NA

1) Certain variant codes cannot be used simultaneously.

S = Included as standard.

M = On modification of a stocked motor, or on new manufacture, the number per order may be limited.

P = New manufacture only.

R = On request.

NA = Not applicable.

Code	Variant	Motor size			M2AA	M2AA	M2AA	M3AA	M3AA	M3AA	M3AA
		56-63	71-80	90-100	112-132	160-200	225-250	112-132	160-180	200-250	280
078	(IM 3601) Flange mounted, DIN C-flange. Small flange with tapped holes. Larger flange than standard version.	NA	P	NA	NA	NA	NA	NA	NA	NA	NA
080	(IM 3001) Flange mounted, DIN A-flange. Large flange with clearance holes. Larger flange than standard version.	NA	P	NA	NA	NA	NA	NA	NA	NA	NA
090	(IM 2101) foot/flange mounted, DIN C-flange, from IM 1001 (B34 from B3). Small flange with tapped holes. Larger flange than standard version.	NA	P	NA	NA	NA	NA	NA	NA	NA	NA
091	(IM 2001) foot/flange mounted, DIN A-flange, from IM 1001 (B35 from B3). Large flange with clearance holes. Larger flange than standard version.	NA	P	NA	NA	NA	NA	NA	NA	NA	NA
200	Flange ring holder.	NA	P	M	R	NA	NA	R	R	R	R
217	Cast iron D-end shield (on aluminum motor).	NA	NA	M	R	R	R	M	M	M	M
218	Flange ring FT 85 (NA for frame size 100).	NA	P	M	NA	NA	NA	NA	NA	NA	NA
219	Flange ring FT 100 (NA for frame size 100).	NA	P	M	NA	NA	NA	NA	NA	NA	NA
220	Flange ring FF 100 (NA for frame size 100).	NA	P	M	NA	NA	NA	NA	NA	NA	NA
223	Flange ring FF 115 (NA for frame size 100).	NA	P	M	NA	NA	NA	NA	NA	NA	NA
224	Flange ring FT 115 (NA for frame size 100).	NA	P	M	NA	NA	NA	NA	NA	NA	NA
226	Flange ring FF 130.	NA	P	M	NA	NA	NA	NA	NA	NA	NA
227	Flange ring FT 130.	NA	P	M	NA	NA	NA	NA	NA	NA	NA
233	Flange ring FF 165.	NA	P	M	NA	NA	NA	NA	NA	NA	NA
234	Flange ring FT 165.	NA	P	M	NA	NA	NA	NA	NA	NA	NA
243	Flange ring FF 215 (NA for frame size 90).	NA	NA	M	NA	NA	NA	NA	NA	NA	NA
244	Flange ring FT 215 (NA for frame size 90).	NA	NA	M	NA	NA	NA	NA	NA	NA	NA
304	PAD mounted according to BS 4999-141.	NA	NA	NA	R	NA	NA	R	NA	R	R
Painting											
114	Special paint colour, standard grade.	M	M	M	M	M	M	M	M	M	M
179	Special paint specification.	NA	NA	R	R	R	R	R	R	R	R
Protection											
005	Protective roof, vertical motor, shaft down. Vertically mounted motors with shaft extension downwards. See also the Accessories section for further information.	M	M	M	M	M	M	M	M	M	M
072	Radial seal at D-end.	P	P	M	R	R	R	P	M	M	M
073	Sealed against oil at D-end.	P	P	NA	NA	NA	NA	NA	NA	NA	NA
158	Degree of protection IP65 or IP65X. Dust proof version.	M	P	P	M	M	M	M	M	M	M
211	Weather protected, IP xx W	NA	NA	P	NA	NA	NA	NA	NA	NA	NA
403	Degree of protection IP 56. Water from waves which splash over must not enter in serious quantities.	M	P	P	M	M	M	M	M	M	M
784	Gamma-seal at D-end.	NA	NA	NA	R	R	R	M	M	M	M
Rating and instruction plates											
002	Restamping voltage, frequency, and output. Continuous duty. All data to be specified in the order.	M	M	M	M	M	M	M	M	M	M
003	Individual serial number.	P	P	M	M	M	M	M	M	M	M
004	Additional text on std rating plate (max 12 digits on free text line).	NA	NA	NA	M	M	M	M	M	M	M
095	Restamping of output. Maintained voltage and frequency. Intermittent duty. All data to be specified in order.	M	M	M	M	M	M	M	M	M	M
098	Stainless rating plate.	M	M	M	M	R	R	M	M	M	M
135	Mounting of additional identification plate, stainless.				NA	NA	NA	R	R	R	R
138	Mounting of additional identification plate, aluminium.	M	M	M	M	M	M	M	M	M	M

¹⁾ Certain variant codes cannot be used simultaneously.

S = Included as standard.

M = On modification of a stocked motor, or on new manufacture, the number per order may be limited.

P = New manufacture only.

R = On request.

NA = Not applicable

Code	Variant	Motor size			M2AA	M2AA	M2AA	M3AA	M3AA	M3AA	M3AA
		56-63	71-80	90-100	112-132	160-200	225-250	112-132	160-180	200-250	280
139	Additional identification plate delivered loose.	M	M	M	M	M	M	M	M	M	M
160	Additional rating plate affixed.	M	M	M	R	R	R	R	R	R	R
161	Additional rating plate delivered loose.	M	M	M	M	M	M	M	M	M	M
163	Frequency converter rating plate. Rating data according to quotation.	NA	NA	NA	M	M	M	M	M	M	M
198	Aluminium rating plate.	S	S	S	R	S	S	R	S	S	S
Shaft and rotor											
069	Two shaft extensions as per basic catalogue. Standard shaft material.	P	P	P	P	R	R	P	P	P	P
070	One or two special shaft extensions, standard shaft material.	P	P	P	R	R	R	R	R	R	R
131	Motor delivered with half-key (key not exceeding shaft material).				M	M	M	M	M	M	M
165	Shaft extension with open key-way.	P	P	P	P	NA	NA	P	P	P	P
410	Stainless/acid-proof steel shaft, standard or non-standard design. One or two shaft extensions.	P	P	P	R	R	R	R	R	R	R
Standards and regulations											
010	Fulfilling CSA Safety Certificate.	P	P	P	M	R	R	M	M	M	M
011	Fulfilling CSA. Energy efficiency verification (010 included). For frame sizes 90-100 own product code, contact ABB.	NA	NA	NA	NA	NA	NA	M	M	M	M
029	Fulfilling Underwriters Laboratory (UL) requirements.	P	P	P	NA	NA	NA	NA	NA	NA	NA
408	Energy efficient design, according to IEEE, Std 112	NA	NA	R	NA	NA	NA	M	M	M	NA
778	Gost R Export/Import Certificate (Russia)	R	R	NA	M	M	M	M	M	M	M
779	SASO Export/Import Certificate (Saudi Arabia)	R	R	NA	M	M	M	M	M	M	M
Stator winding temperature sensors											
121	Bimetal detectors, break type (NCC), (3 in series), 130°C, in stator winding. Two-speed motors for only new manufacture.	M	M	M	M	M	M	M	M	M	M
122	Bimetal detectors, break type (NCC), (3 in series), 150°C, in stator winding. Two-speed motors for only new manufacture.	M	M	M	M	M	M	M	M	M	M
123	Bimetal detectors, break type (NCC), (3 in series), 170°C, in stator winding. Two-speed motors for only new manufacture.	M	M	M	M	M	M	M	M	M	M
124	Bimetal detectors, break type (NCC), (3 in series), 140°C, in stator winding. Two-speed motors for only new manufacture.	M	M	NA	M	M	M	M	M	M	M
125	Bimetal detectors, break type (NCC), (2 x 3 in series), 150°C, in stator winding. Two-speed motors only for new manufacture.	M	M	M	M	M	M	M	M	M	M
127	Bimetal detectors, break type (NCC), (3 in series, 130°C & 3 in series, 150°C), in stator winding. Two-speed motors only for new manufacture.	M	M	M	M	M	M	M	M	M	M
321	Bimetal detectors, closing type (NO), (3 in parallel), 130°C, in stator winding.	NA	NA	P	R	NA	NA	R	R	R	R
322	Bimetal detectors, closing type (NO), (3 in parallel), 150°C, in stator winding.	NA	NA	P	R	R	R	R	R	R	R
323	Bimetal detectors, closing type (NO), (3 in parallel), 170°C, in stator winding.	NA	NA	P	R	R	R	R	R	R	R
325	Bimetal detectors, closing type (NO), (2x3 in parallel), 150°C, in stator winding.	NA	NA	P	R	R	R	R	R	R	R
435	PTC - thermistors, (3 in series), 130°C, 3 in stator winding. Two-speed motors only for new manufacture.	M	M	M	M	M	M	M	M	M	M
436	PTC thermistors, 150°C, 3 in series. Motor sizes 160-180 as modification. Two-speed motors only for new manufacture.	M	M	M	M	M	S	M	M	S	S
437	PTC - thermistors, (3 in series), 170°C, in stator winding. Two-speed motors only for new manufacture.	M	M	M	M	M	M	M	M	M	M
439	PTC - thermistors, (2x3 in series), 150°C, in stator winding. Two-speed motors only for new manufacture.	M	M	M	M	M	M	M	M	M	M

¹⁾ Certain variant codes cannot be used simultaneously.

S = Included as standard.

M = On modification of a stocked motor, or on new manufacture, the number per order may be limited.

P = New manufacture only.

R = On request.

NA = Not applicable.

Code	Variant	Motor size			M2AA	M2AA	M2AA	M3AA	M3AA	M3AA	M3AA
		56-63	71-80	90-100	112-132	160-200	225-250	112-132	160-180	200-250	280
440	PTC - thermistors, (3 in series, 110 °C, & 3 in series, 130°C), in stator winding. Two-speed motors only for new manufacture.	M	M	M	R	R	R	R	R	R	R
441	PTC - thermistors, (3 in series, 130 °C, & 3 in series, 150°C), in stator winding. Two-speed motors only for new manufacture.	M	M	M	M	M	M	M	M	M	M
442	PTC - thermistors, (3 in series, 150 °C & 3 in series, 170°C), in stator winding. Two-speed motors only for new manufacture.	M	M	R	M	M	M	M	M	M	M
445	PT100 (1 per phase) in stator winding. Measurement current max. 10 mA. Temperature: 0 10 20 50 100 150 °C. Resistance: 100 103.9 107.7 119.3 128.5 158 Ohm. Monitoring unit, more information from ABB.	NA	NA	R	M	M	M	M	M	M	M
446	PT100 (2 per phase) in stator winding. Measurement current max. 10 mA. Temperature: 0 10 20 50 100 150 °C. Resistance: 100 103.9 107.7 119.3 128.5 158 Ohm. Monitoring unit, more information from ABB.	NA	NA	R	NA	M	M	NA	M	M	M
Terminal box											
015	Motor supplied in D-connection. Single speed motors only.	M	M	M	M	M	M	M	M	M	M
017	Motor supplied in Y-connection. Single speed motors only.	M	M	M	M	M	M	M	M	M	M
018	D connection in terminal box (reconnection from Y.) Single phase Steinmetz.	NA	NA	NA	NA	NA	NA	NA	NA	NA	NA
019	Larger than standard terminal box. Standard for frame size 280, and for sizes 200-250 by voltage code S.	NA	NA	NA	M	M	M	M	M	M	NA
021	Terminal box on left-hand side, seen from D-end.	NA	M	M	NA	NA	R	NA	NA	P	P
112	Mounting of plug-in contact.	NA	NA	R	R	NA	NA	R	NA	NA	NA
136	Extended cable connection, standard terminal box. 2 m long connection cable.	P	P	R	R	R	R	R	R	R	R
137	Extended cable connection, low terminal box, 'flying leads'.	NA	NA	P	NA	NA	NA	NA	NA	NA	NA
180	Terminal box on right-hand side, seen from D-end.	NA	M	M	NA	NA	R	NA	NA	P	P
187	Cable glands of non-standard design.	NA	NA	NA	R	R	R	R	R	R	R
230	Standard cable glands.	M	M	M	M	M	M	M	M	M	M
402	Terminal box adapted for AI cables.	NA	NA	NA	NA	NA	NA	NA	NA	P	P
413	Extended cable connection, no terminal box.	NA	NA	NA	NA	NA	R	NA	NA	R	R
418	Separate terminal box for temperature detectors.	NA	NA	R	M	M	M	M	M	M	M
467	Lower than standard terminal box and rubber extended cable. Terminal box without screw terminals and extended rubber connection cable, 2 m.	NA	NA	NA	M	R	R	M	M	M	M
468	Non-standard cable entry direction (please state direction).	NA	NA	NA	R	R	R	R	R	R	R
469	Axial cable entry direction, terminal box 4x90° turnable.	NA	NA	NA	R	R	R	R	R	R	R
729	Cable flanges without holes / blank gland plates.	NA	NA	NA	NA	NA	M	NA	NA	M	M
731	Two standard cable glands.	NA	M	M	M	M	M	M	M	M	M
739	Prepared for metric cable glands according to DIN 429225, draft Aug. 1999.	NA	NA	NA	M	S	R	M	S	M	S
740	Prepared for PG cable glands.	NA	NA	NA	M	R	R	M	M	M	M
Testing											
140	Test confirmation.	M	M	M	M	M	M	M	M	M	M
145	Type test report from catalogue motor, 400 V 50 Hz.	M	M	M	M	M	M	M	M	M	M
146	Type test with report for motor from specific delivery batch.	P	P	P	M	M	M	M	M	M	M
147	Type test report with motor from specific delivery batch, customer witnessed.	P	P	P	M	M	M	M	M	M	M
148	Routine test report.	P	P	M	M	M	M	M	M	M	M
149	Test according to separate test specification.	NA	NA	R	R	R	R	R	R	R	R
153	Reduced test for classification society.	P	P	P	M	M	M	M	M	M	M

¹⁾ Certain variant codes cannot be used simultaneously.

S = Included as standard.

M = On modification of a stocked motor, or on new manufacture, the number per order may be limited.

P = New manufacture only.

R = On request.

NA = Not applicable.

Code	Variant	Motor size			M2AA	M2AA	M2AA	M3AA	M3AA	M3AA	M3AA
		56-63	71-80	90-100	112-132	160-200	225-250	112-132	160-180	200-250	280
1)											
221	Type test and multi-point load test with report for motor from specific delivery batch.	R	R	P	M	M	M	M	M	M	M
222	Torque/speed curve, type test and multi-point load test with report from specific delivery batch.	R	R	P	M	M	M	M	M	M	M
760	Vibration level test.	P	P	R	M	M	M	M	M	M	M
761	Vibration spectrum test.	NA	NA	NA	R	R	R	R	R	R	R
762	Noise level test.	P	P	R	M	M	M	M	M	M	M
763	Noise spectrum test.	NA	NA	M	R	R	R	R	R	R	R
764	Complete test with ABB frequency converter.	NA	NA	R	R	R	R	R	R	R	R
Variable speed drives											
<i>See also the Accessories section for further information.</i>											
<i>For long cables, see code 405 "Insulation systems".</i>											
701	Insulated bearing at N-end. For fan and pump duty up to 500 V.	NA	NA	NA	NA	NA	NA	NA	NA	M	M
704	EMC cable gland.	NA	NA	NA	M	R	R	M	M	M	M
Separate motor cooling											
183	Separate motor cooling (fan axial, N-end).	NA	P	R	NA	R	R	NA	M	M	M
189	Separate motor cooling, IP44, 400V, 50Hz (fan axial, N-end).	NA	NA	NA	M	M	M	M	M	M	M
Mounting of tacho; tacho not included											
182	Pulse sensor mounted as specified.	NA	NA	R	R	NA	NA	R	R	R	R
470	Prepared for hollow shaft pulse tacho. (Leine & Linde equivalent).	R	R	R	P	R	R	P	M	M	M
570	Prepared for hollow shaft pulse tacho (L&L 562).	NA	NA	R	P	M	M	P	M	M	M
Mounting of tacho; tacho included											
472	1024 of pulse tacho, (Leine & Linde equivalent). Hollow shaft version.	R	R	R	P	R	R	P	M	M	M
473	2048 of pulse tacho. (Leine & Linde equivalent). Hollow shaft version.	R	R	R	P	R	R	P	M	M	M
572	1024 pulse tacho (L&L 562).	NA	NA	R	P	M	M	P	M	M	M
573	2048 pulse tacho (L&L 562).	NA	NA	R	P	M	M	P	M	M	M
Separate motor cooling & prepared for tacho; tacho not included											
474	Separate motor cooling and prepared for hollow shaft pulse tacho. (Leine & Linde equivalent).	NA	NA	R	P	R	R	P	M	M	M
Separate motor cooling & tacho; tacho included											
476	Separate motor cooling (fan axial, N-end) and 1024 pulse tacho. (Leine & Linde equivalent).	NA	NA	R	P	R	R	P	M	M	M
477	Separate motor cooling (fan axial, N-end) and 2048 pulse tacho. (Leine & Linde equivalent).	NA	NA	R	P	R	R	P	M	M	M
574	Separate motor cooling (fan axial, N-end) and prepared for hollow shaft tacho (L&L 562).	NA	NA	R	NA	R	R	NA	M	M	M
576	Separate motor cooling (fan axial, N-end) and 1024 pulse tacho (L&L 562).	NA	NA	R	NA	R	R	NA	M	M	M
577	Separate motor cooling (fan axial, N-end) and 2048 pulse tacho (L&L 562).	NA	NA	R	NA	R	R	NA	M	M	M
578	Separate motor cooling, IP44, 400V, 50Hz (fan axial, N-end) and prepared for hollow shaft tacho (L&L 562).	NA	NA	NA	P	M	M	P	M	M	M
580	Separate motor cooling, IP44, 400V, 50Hz (fan axial, N-end) and 1024 pulse tacho (L&L 562).	NA	NA	NA	P	M	M	P	M	M	M
581	Separate motor cooling, IP44, 400V, 50Hz (fan axial, N-end) and 2048 pulse tacho (L&L 562).	NA	NA	NA	P	M	M	P	M	M	M

1) Certain variant codes cannot be used simultaneously.

S = Included as standard.

M = On modification of a stocked motor, or on new manufacture, the number per order may be limited.

P = New manufacture only.

R = On request.

NA = Not applicable.

Code	Variant	Motor size			M2AA	M2AA	M2AA	M3AA	M3AA	M3AA	M3AA
		56- 63	71- 80	90- 100	112- 132	160- 200	225- 250	112- 132	160- 180	200- 250	280
1) Y/D starting											
117	Terminals for Y/D start at both speeds (two speed motors with separate windings).	NA	NA	P	NA	NA	NA	NA	P	P	NA
118	Terminals for Y/D start at high speed (two speed motors with separate windings).	NA	NA	NA	P	NA	NA	P	NA	NA	NA

1) Certain variant codes cannot be used simultaneously.

S = Included as standard.

M = On modification of a stocked motor,
or on new manufacture,
the number per order may be limited.

P = New manufacture only.

R = On request.

NA = Not applicable.

General purpose aluminum motors

Sizes 56-100

Dimension drawings

**Foot-mounted motor;
IM B3 (IM 1001), IM 1002**

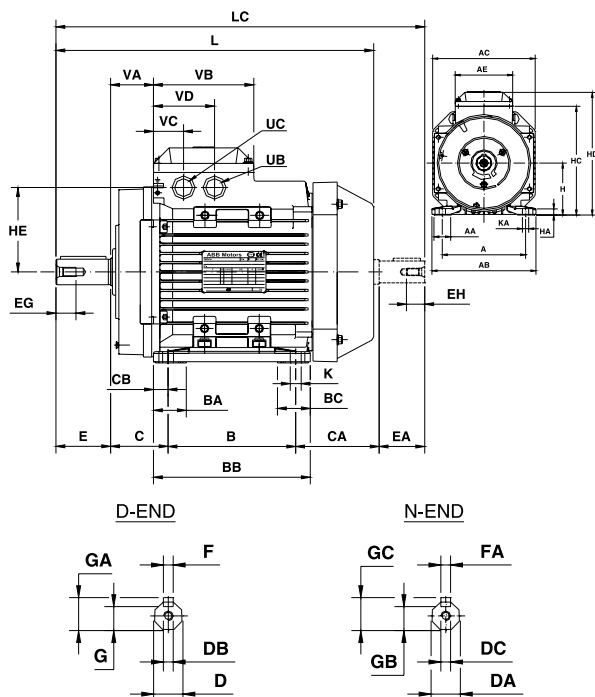

**Flange-mounted motor, large flange;
IM B5 (IM 3001), IM 3002**

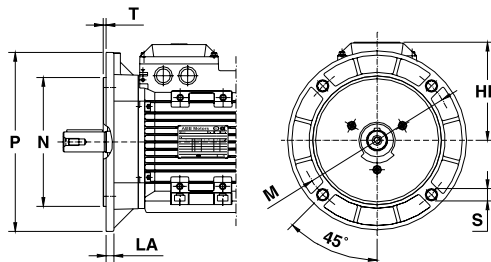

**Flange-mounted motor, small flange;
IM B14 (IM 3601)**

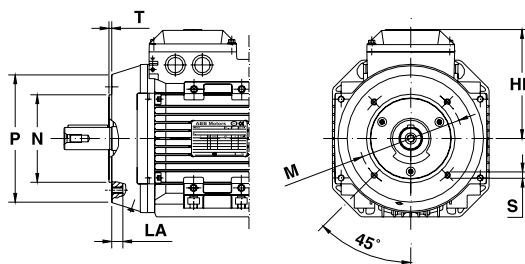

IM B3 (IM 1001), IM 1002

Motor size	A	AA	AB	AC	AE	B	BB	C	CA	CB	D	DA	DB	DC	E	EA	EG	EH	F	FA
56	90	18	108	110	72	71	85	36	78	7	9	9	M3	M3	20	20	9	9	3	3
63	100	26	120	120	72	80	96	40	71	8	11	11	M4	M4	23	23	10	10	4	4
71	112	24	136	130	85	90	110	45	78	10	14	11	M5	M4	30	23	13	10	5	4
80	125	28	154	150	97	100	125	50	80	12.5	19	14	M6	M5	40	30	16	13	6	5
90 S	140	27	170	177	110	100	125	56	81	12.5	24	14	M8	M5	50	30	19	12.5	8	5
90 L	140	27	170	177	110	125	150	56	81	12.5	24	14	M8	M5	50	30	19	12.5	8	5
100	160	32	197	197	110	140	172	63	91	16	28	19	M10	M6	60	40	22	19	8	6

Motor size	G	GA	GB	GC	H	HA	HC	HD	HE	K	KA	L	LC	UB	UC	VA	VB	VC	VD
56	7.2	10.2	7.2	10.2	56	8	110	159	71	5.8	9	197	225	Pg11	M16x1.5	30	72	26	53
63	8.5	12.5	8.5	12.5	63	10	120	171	76	7	11	205	237	Pg11	M16x1.5	36	72	26	53
71	11	16	8.5	12.5	71	9	130	176	63	7	10	238	266	Pg16	M20x1.5	35	92	22	57
80	15.5	21.5	11	16	80	10	150	190	67	10	15	265	300	Pg16	M20x1.5	37	100	26	61
90 S	20	27	11	16	90	11	177	217	82.5	10	14	282	317	M20x1.5	M25x1.5	43.5	110	33	67
90 L	20	27	11	16	90	11	177	217	82.5	10	14	307	342	M20x1.5	M25x1.5	43.5	110	33	67
100	24	31	15.5	21.5	100	12	198	237	92.5	12	15	349	394	M20x1.5	M25x1.5	47	110	33	67

IM B5 (IM 3001), IM 3002

Motor size	HB	LA	M	N	P	S	T
56	103	10	100	80	120	7	3
63	108	10	115	95	140	10	3
71	105	10	130	110	160	10	3.5
80	110	12	165	130	200	12	3.5
90	127	10	165	130	200	12	3.5
100	137	11	215	180	250	15	4

IM B14 (IM 3601), IM 3602

Motor size	HB	LA	M	N	P	S	T
56	103	10	65	50	80	M5	2.5
63	108	10	75	60	90	M5	2.5
71	105	10	85	70	105	M6	2.5
80	110	10	100	80	120	M6	3
90	127	13	115	95	140	M8	3
100	137	14	130	110	160	M8	3.5

Tolerances:

A, B	+ - 0.8	H	+0 -0.5
D, DA	ISO j6	N	ISO j6
F, FA	ISO h9	C, CA	+ - 0.8

Above table gives the main dimensions in mm.
For detailed drawings please see our web-pages
'www.abb.com/motors&drives' or contact us.

General purpose aluminum motors

Sizes 56-100

Dimension drawings

Foot- and flange-mounted motor;
IM B35 (IM 2001), IM 2002, large flange

Foot- and flange-mounted motor;
IM B34 (IM 2101), IM 2102, small flange

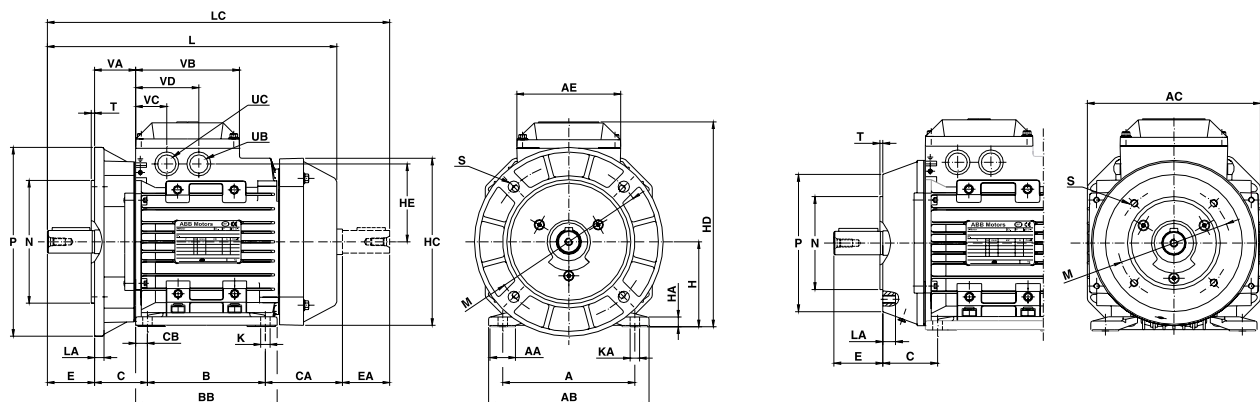

IM B35 (IM 2001), IM 2002, IM B34 (IM 2101), IM 2102

Motor size	A	AA	AB	AC	AE	B	BB	C	CA	CB	D	DA	DB	DC	E	EA	EG	EH	F	FA
56	90	18	108	110	72	71	85	36	78	7	9	9	M3	M3	20	20	9	9	3	3
63	100	26	120	120	72	80	96	40	71	8	11	11	M4	M4	23	23	10	10	4	4
71	112	24	136	130	85	90	110	45	78	10	14	11	M5	M4	30	23	13	10	5	4
80	125	28	154	150	97	100	125	50	80	12.5	19	14	M6	M5	40	30	16	13	6	5
90 S	140	27	170	177	110	100	125	56	81	12.5	24	14	M8	M5	50	30	19	12.5	8	5
90 L	140	27	170	177	110	125	150	56	81	12.5	24	14	M8	M5	50	30	19	12.5	8	5
100	160	32	197	197	110	140	172	63	91	16	28	19	M10	M6	60	40	22	19	8	6

Motor size	G	GA	GB	GC	H	HA	HC	HD	HE	K	KA	L	LC	UB	UC	VA	VB	VC	VD
56	7.2	10.2	7.2	10.2	56	8	110	159	71	5.8	9	197	225	Pg11	M16x1.5	30	72	26	53
63	8.5	12.5	8.5	12.5	63	10	120	171	76	7	11	205	237	Pg11	M16x1.5	36	72	26	53
71	11	16	8.5	12.5	71	9	130	176	63	7	10	238	266	Pg16	M20x1.5	35	92	22	57
80	15.5	21.5	11	16	80	10	150	190	67	10	15	265	300	Pg16	M20x1.5	37	100	26	61
90 S	20	27	11	16	90	10	177	217	82.5	10	14	282	317	M20x1.5	M25x1.5	43.5	110	33	67
90 L	20	27	11	16	90	10	177	217	82.5	10	14	307	342	M20x1.5	M25x1.5	43.5	110	33	67
100	24	31	15.5	21.5	100	12	197	237	92.5	12	15	349	394	M20x1.5	M25x1.5	47	110	33	67

IM B35 (IM 2001), IM 2002

Motor size	HB	LA	M	N	P	S	T
56	103	10	100	80	120	7	3
63	108	10	115	95	140	10	3
71	105	10	130	110	160	10	3.5
80	110	12	165	130	200	12	3.5
90	127	10	165	130	200	12	3.5
100	137	11	215	180	250	15	4

IM B34 (IM 2101), IM 2102

Motor size	HB	LA	M	N	P	S	T
56	103	10	65	50	80	M5	2.5
63	108	10	75	60	90	M5	2.5
71	105	10	85	70	105	M6	2.5
80	110	10	100	80	120	M6	3
90	127	13	115	95	140	M8	3
100	137	14	130	110	160	M8	3.5

Tolerances:

A, B	+ - 0.8	H	+0 -0.5
D, DA	ISO j6	N	ISO j6
F, FA	ISO h9	C, CA	+ - 0.8

Above table gives the main dimensions in mm.

For detailed drawings please see our web-pages
'www.abb.com/motors&drives' or contact us.

General purpose aluminum motors

Sizes 71-100

Dimension drawings

Special design with two-piece flanges

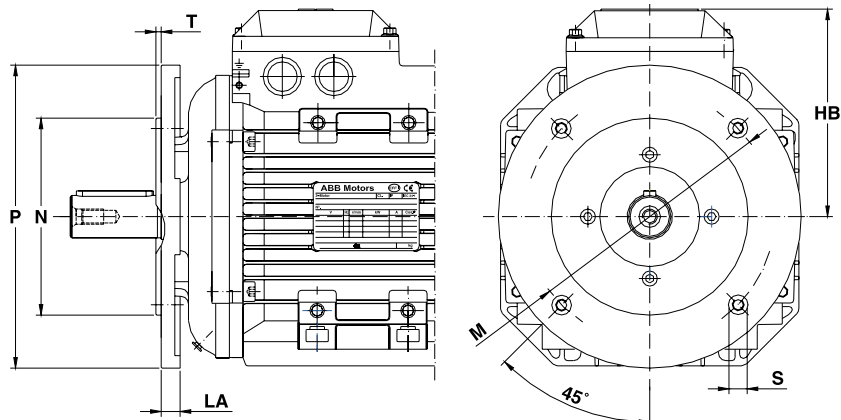

2

Motor size	IEC Flange	Flange dimensions							Variant code ¹⁾	
		HB	P	M	N	LA	S ²⁾	T	FF	FT
71	FT85	105	105	85	70	7.5	M6	2.5	-	218
	FF100 / FT100	105	120	100	80	7.5	M6	3	220	219
	FF115 / FT115	105	140	115	95	9.5	M8	3	223	224
	FF130 / FT130	105	160	130	110	9.5	M8	3.5	226	227
	FF165 / FT165	105	200	165	130	10.5	M10	3.5	233	234
80	FT85	110	105	85	70	7.5	M6	2.5	-	218
	FF100 / FT100	110	120	100	80	7.5	M6	3	220	219
	FF115 / FT115	110	140	115	95	9.5	M8	3	223	224
	FF130 / FT130	110	160	130	110	9.5	M8	3.5	226	227
	FF165 / FT165	110	200	165	130	10.5	M10	3.5	233	234
90	FT85	127	105	85	70	7.5	M6	2.5	-	218
	FF100 / FT100	127	120	100	80	7.5	M6	3	220	219
	FF115 / FT115	127	140	115	95	9.5	M8	3	223	224
	FF130 / FT130	127	160	130	110	9.5	M8	3.5	226	227
	FF165 / FT165	127	200	165	130	10.5	M10	3.5	233	234
100	FF130 / FT130	137	160	130	110	9.5	M8	3.5	226	227
	FF165 / FT165	137	200	165	130	10.5	M10	3.5	233	234
	FF215 / FT215	137	250	215	180	12.5	M12	4	243	244

Data for smaller frame sizes on request.

¹⁾ Variant code 200 'Flange ring holder' must be added when using the variant codes mentioned below.

²⁾ Flanges with clearance (FF) or tapped (FT) holes for indicated screws.

Tolerances:

N ISO j6

General purpose aluminum motors

Dimension drawings

Sizes 112-132

Foot-mounted motor; IM B 3 (IM 1001), IM 1002

Flange-mounted motor, large flange; IM B 5 (IM 3001), IM 3002

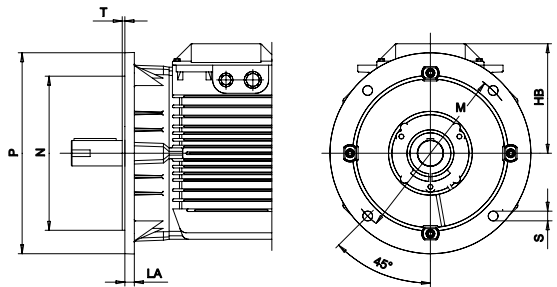
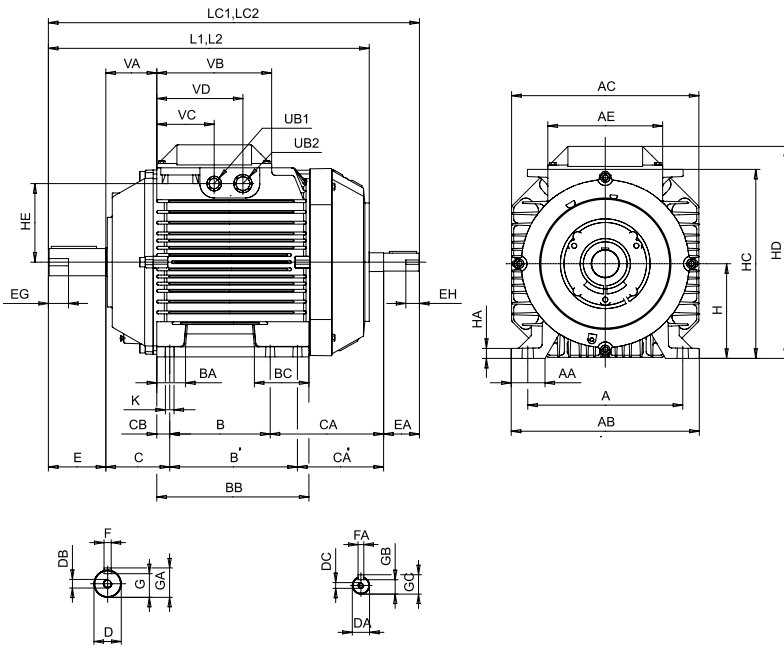

Flange-mounted motor, small flange; IM B 14 (IM 3601), IM 3602

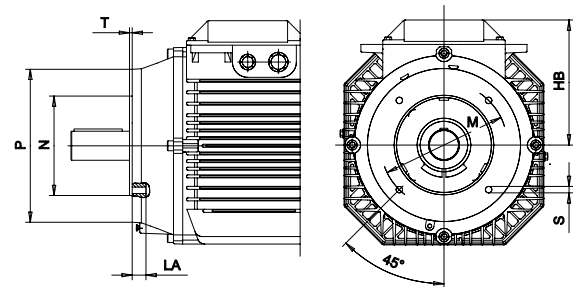

IM B 3 (IM 1001)

Motor size	A	AA	AB	AC	AE	B	B'	BA	BB	BC	C	CA	CA'	CB	D	DA	DB	DC	E ^{B)}	EA	EG	EH	F	FA
112 ¹⁾	190	41	222	221	160	140	-	31	168	31	70	115.5	-	14	28	19	M10	M8	60	40	22	19	8	6
112 ²⁾	190	41	222	221	160	140	-	31	168	31	70	138	-	14	28	19	M10	M8	60	40	22	19	8	6
132 ³⁾	216	47	262	261	160	140	178 ^{A)}	40	212	76	89	158	120	18	38	24	M12	M8	80	50	28	19	10	8
132 ⁴⁾	216	47	262	261	160	140 ^{A)}	178	40	212	76	89	191	153	18	38	24	M12	M8	80	50	28	19	10	8

Motor size	G	GA	GB	GC	H	HA	HC	HD	HE	K	L	L1	L2	LC	LC1	LC2	UB1 ^{C)}	UB2 ^{C)}	VA	VB	VC ^{D)}	VD1	VD2
112 ¹⁾	24	31	15.5	21.5	112	12	226	258	92	12	361 ^{F)}	361 ^{F)}	361 ^{F)}	421.5	421.5	421.5	M20	M25	60	160	80	120	40
112 ²⁾	24	31	15.5	21.5	112	12	226	258	92	12	388 ^{F)}	388 ^{F)}	388 ^{F)}	448	448	448	M20	M25	60	160	80	120	40
132 ³⁾	33	41	20	27	132	14	263.5	295.5	109.5	12	447 ^{G)}	447 ^{G)}	447 ^{G)}	517	517	517	M20	M25	71	160	80	120	40
132 ⁴⁾	33	41	20	27	132	14	263.5	295.5	109.5	12	481.5 ^{G)}	481.5 ^{G)}	481.5 ^{G)}	550	550	550	M20	M25	71	160	80	120	40

IM B 5 (IM 3001)

Motor size	HB	LA	M	N	P	S	T
112 ¹⁾	146	11	215	180	250	14.5	4
112 ²⁾	146	11	215	180	250	14.5	4
132 ³⁾	163.5	14	265	230	300	14.5	4
132 ⁴⁾	163.5	14	265	230	300	14.5	4

IM B 14 (IM 3601)

Motor size	HB	LA	M	N	P	S	T
112 ¹⁾	146	20	130	110	160	M8	3.5
112 ²⁾	146	20	130	110	160	M8	3.5
132 ³⁾	163.5	18	165	130	200	M10	3.5
132 ⁴⁾	163.5	18	165	130	200	M10	3.5

- Tolerances**
- A, B ISO js14
 - C, CA +2 -2
 - D28 ISO j6
 - D38 ISO k6
 - DA ISO j6
 - F, FA ISO h9
 - H +0 -0.5
 - N ISO j6
- 1) M2AA: M-2, M-4. M3AA: M-6, M8
 - 2) all 112 excl¹⁾
 - 3) M2AA: SA-2, SB-2, S-4, M-4. M3AA: SA-2, S-4, S-6, MA-6, MB-6, S-8, M-8, S-Two-speed
 - 4) all 132 excl³⁾

- A) Not acc to IEC.
- B) For IM B5 and IM B35: Shoulder of shaft extension and contact surface of flange are in the same plane.
- C) Knockout openings.
- D) Dimensions to UB1.

- E) Dimensions to UB2 (VD1 = right side, VD2 = left side) as viewed from the D-end.
- F) For variant code 053 increased by 7.5mm
- G) For variant code 053 increased by 5.5mm

Above table gives the main dimensions in mm. For detailed drawings please see our web-pages 'www.abb.com/motors&drives' or contact us.

General purpose aluminum motors

Sizes 112-132

Dimension drawings

Foot- and flange-mounted motor; IM B 35 (IM 2001), IM 2002, large flange

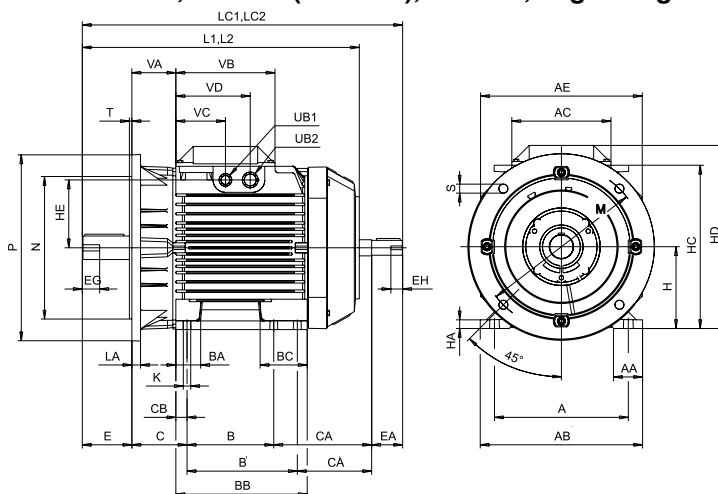

Foot- and flange-mounted motor; IM B 34 (IM 2101), IM 2102, small flange

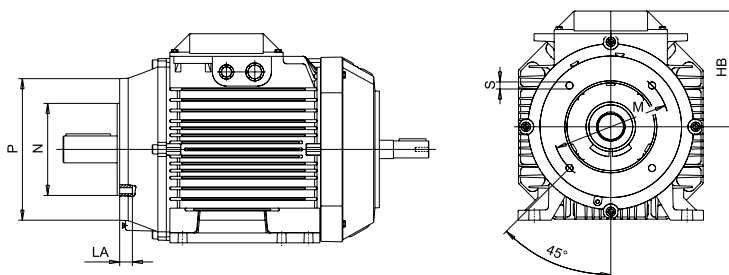

IM B 35 (IM 2001), IM 2002

Motor size	A	AA	AB	AC	AE	B	B'	BA	BB	BC	C	CA	CA'	CB	D	DA	DB	DC	E ^{B)}	EA	EG	EH	F	FA
112 ¹⁾	190	41	222	221	160	140	-	31	168	31	70	115.5	-	14	28	19	M10	M8	60	40	22	19	8	6
112 ²⁾	190	41	222	221	160	140	-	31	168	31	70	138	-	14	28	19	M10	M8	60	40	22	19	8	6
132 ³⁾	216	47	262	261	160	140	178 ^{A)}	40	212	76	89	158	120	18	38	24	M12	M8	80	50	28	19	10	8
132 ⁴⁾	216	47	262	261	160	140 ^{A)}	178	40	212	76	89	191	153	18	38	24	M12	M8	80	50	28	19	10	8

Motor size	G	GA	GB	GC	H	HA	HC	HD	HE	K	L	L1	L2	LC	LC1	LC2	UB1 ^{C)}	UB2 ^{C)}	VA	VB	VC ^{D)}	VD1	VD2
112 ¹⁾	24	31	15.5	21.5	112	12	226	258	92	12	361 ^{F)}	361 ^{F)}	361 ^{F)}	421.5	421.5	421.5	M20	M25	60	160	80	120	40
112 ²⁾	24	31	15.5	21.5	112	12	226	258	92	12	388 ^{F)}	388 ^{F)}	388 ^{F)}	448	448	448	M20	M25	60	160	80	120	40
132 ³⁾	33	41	20	27	132	14	263.5	295.5	109.5	12	447 ^{G)}	447 ^{G)}	447 ^{G)}	517	517	517	M20	M25	71	160	80	120	40
132 ⁴⁾	33	41	20	27	132	14	263.5	295.5	109.5	12	481.5 ^{G)}	481.5 ^{G)}	481.5 ^{G)}	550	550	550	M20	M25	71	160	80	120	40

IM B 35 (IM 2001)

Motor size	HB	LA	M	N	P	S	T
112 ¹⁾	146	11	215	180	250	14.5	4
112 ²⁾	146	11	215	180	250	14.5	4
132 ³⁾	163.5	14	265	230	300	14.5	4
132 ⁴⁾	163.5	14	265	230	300	14.5	4

IM B 34 (IM 2101)

Motor size	HB	LA	M	N	P	S	T
112 ¹⁾	146	20	130	110	160	M8	3.5
112 ²⁾	146	20	130	110	160	M8	3.5
132 ³⁾	163.5	18	165	130	200	M10	3.5
132 ⁴⁾	163.5	18	165	130	200	M10	3.5

Tolerances

A, B ISO js14
 C, CA +2 -2
 D28 ISO j6
 D38 ISO k6
 DA ISO j6
 F, FA ISO h9
 H +0 -0.5
 N ISO j6

¹⁾ M2AA: M-2, M-4. M3AA: M-6, M8
²⁾ all 112 excl 1)
³⁾ M2AA: SA-2, SB-2, S-4, M-4. M3AA: SA-2, S-4, S-6, MA-6, MB-6, S-8, M-8, S-Two-speed
⁴⁾ all 132 excl 3)

^{A)} not acc to IEC.

^{B)} For IM B5 and IM B35: Shoulder of shaft extension and contact surface of flange are in the same plane.

^{C)} Knockout openings.

^{D)} Dimensions to UB1.

^{E)} Dimensions to UB2 (VD1 = right side, VD2 = left side) as viewed from the D-end.
^{F)} For variant code 053 increased by 7.5mm
^{G)} For variant code 053 increased by 5.5mm

Above table gives the main dimensions in mm. For detailed drawings please see our web-pages 'www.abb.com/motors&drives' or contact us.

General purpose aluminum motors

M2AA 160-200

Dimension drawings

Foot-mounted motor; IM B3 (IM 1001), IM 1002

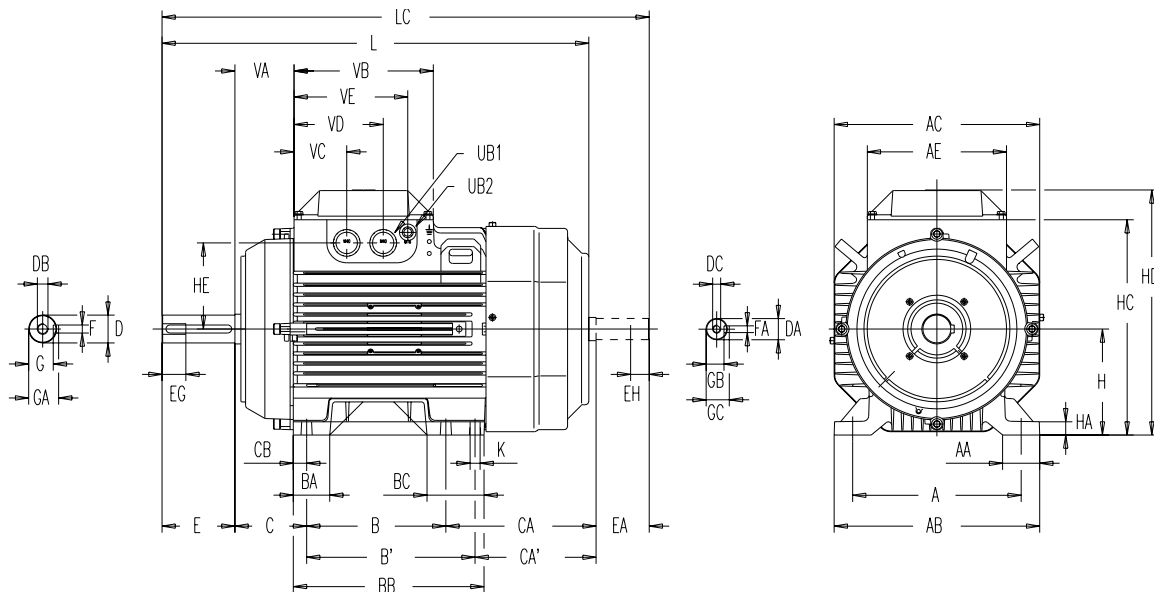

IM B3 (IM 1001), IM 1002

Motor size	A	AA	AB	AC	AE	B ³⁾	B' ⁸⁾	BA	BB	BC	C	CA	CA'	CB	D	DA	DB	DC	E	EA	EG	EH	F
160 ³⁾	254	56	310	310	210	210	254	55	287.5	86	108	185.5	141.5	20	42	32	M16	M12	110	80	36	28	12
180 ⁴⁾	279	65.5	340	310	210	241	279	58	316	88	121	185.5	141.5	25	48	32	M16	M12	110	80	36	28	14
180 ⁵⁾	279	65.5	340	310	210	241	279	58	316	88	121	226.5	182.5	25	48	32	M16	M12	110	80	36	28	14
200 ⁶⁾	318	64	380	360	210	267	305	98	365	98	133	218	180	30	55	32	M20	M12	110	80	42	28	16
200 ⁷⁾	318	64	380	360	210	267	305	98	365	98	133	238	200	30	55	32	M20	M12	110	80	42	28	16

Motor size	FA	G	GA	GB	GC	H	HA	HC	HD	HE	K	L	LC	UB1 ²⁾	UB2 ²⁾	VA	VB	VC	VD	VE
160 ³⁾	10	37	45	27	35	160	20	325	370	130	15	602.5	693.5	2*M40	M16	89	210	84.5	134.5	167.5
180 ⁴⁾	10	42.5	51.5	27	35	180	20	345	390	130	15	602.5	693.5	2*M40	M16	89	210	84.5	134.5	167.5
180 ⁵⁾	10	42.5	51.5	27	35	180	20	345	390	130	15	643.5	734.5	2*M40	M16	89	210	84.5	134.5	167.5
200 ⁶⁾	10	49	59	27	35	200	25	380	425	145	18	711.5	801.5	2*M40	M16	109	210	84.5	134.5	167.5
200 ⁷⁾	10	49	59	27	35	200	25	380	425	145	18	732	821.5	2*M40	M16	109	210	84.5	134.5	167.5

Tolerances

A, B ISO js14
 C, CA 0 +2
 DA 32 ISO k6
 D 45-48 ISO k6
 D 55 ISO m6
 F, FA ISO h9
 H +0 -0.5

²⁾ Knockout openings.

³⁾ MA-2, M-2, L-2, M-4, L-4

⁴⁾ M-2, M-4

⁵⁾ L-4

⁶⁾ LA-4

⁷⁾ L-2, L-4

⁸⁾ 160 M, 180 M: B' not acc. to IEC

160 L, 180 L, 200 LA: B not acc. to IEC

Above table gives the main dimensions in mm.

For detailed drawings please see our web-pages
 'www.abb.com/motors&drives' or contact us.

General purpose aluminum motors

M2AA 160-200

Dimension drawings

Flange-mounted motor; IM B5 (IM 3001), IM 3002

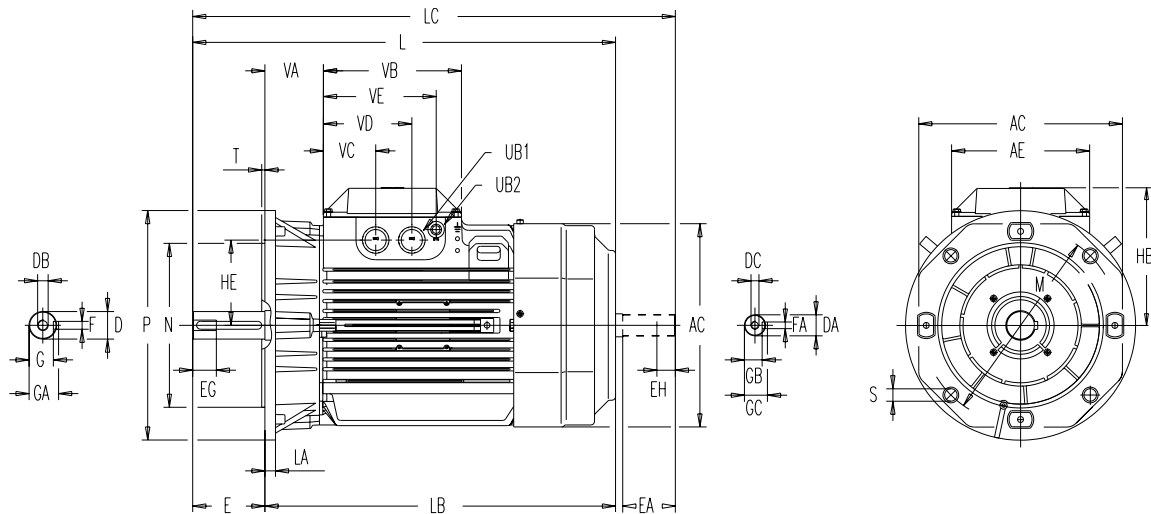

IM B5 (IM 3001), IM 3002

Motor size	AC	AE	D	DA	DB	DC	E ⁸⁾	EA	EG	EH	F	FA	G	GA	GB	GC	HB	HE
160 ³⁾	310	210	42	32	M16	M12	110	80	36	28	12	10	37	45	27	35	210	130
180 ⁴⁾	310	210	48	32	M16	M12	110	80	36	28	14	10	42.5	51.5	27	35	210	130
180 ⁵⁾	310	210	48	32	M16	M12	110	80	36	28	14	10	42.5	51.5	27	35	210	130
200 ⁶⁾	360	210	55	32	M20	M12	110	80	42	28	16	10	49	59	27	35	210	145
200 ⁷⁾	360	210	55	32	M20	M12	110	80	42	28	16	10	49	59	27	35	210	145

Motor size	L	LA	LB	LC	M	N	P	S	T	UB1 ²⁾	UB2 ²⁾	VA	VB	VC	VD	VE
160 ³⁾	602.5	16	492.5	693.5	300	250	350	19	5	2*M40	M16	89	210	79.5	134.5	171.5
180 ⁴⁾	602.5	16	492.5	693.5	300	250	350	19	5	2*M40	M16	89	210	79.5	134.5	171.5
180 ⁵⁾	643.5	16	533.5	734.5	300	250	350	19	5	2*M40	M16	89	210	79.5	134.5	171.5
200 ⁶⁾	711.5	20	601.5	801.5	350	300	400	19	5	2*M40	M16	109	210	79.5	134.5	171.5
200 ⁷⁾	732	20	622	821.5	350	300	400	19	5	2*M40	M16	109	210	79.5	134.5	171.5

Tolerances

DA 32	ISO k6
D 45-48	ISO k6
D 55	ISO m6
F, FA	ISO h9
N	ISO j6

²⁾ Knockout openings.

³⁾ MA-2, M-2, L-2, M-4, L-4

⁴⁾ M-2, M-4

⁵⁾ L-4

⁶⁾ LA-2

⁷⁾ L-2, L-4

⁸⁾ Shoulder of shaft extension and contact surface of flange are in the same plane.

Above table gives the main dimensions in mm.
For detailed drawings please see our web-pages
'www.abb.com/motors&drives' or contact us.

General purpose aluminum motors

M2AA 160-200

Dimension drawings

Foot- and flange-mounted motor; IM B35 (IM 2001), IM 2002

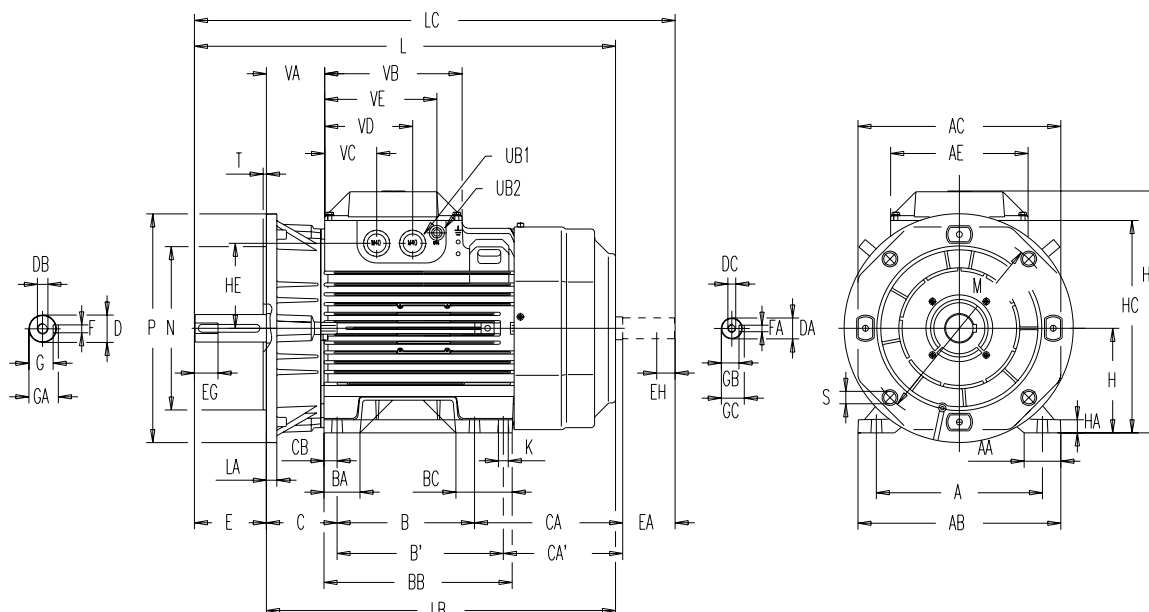

IM B35 (IM 2001), IM 2002

Motor size	A	AA	AB	AC	AE	B ⁹⁾	B' ⁹⁾	BA	BB	BC	C	CA	CA'	CB	D	DA	DB	DC
160 ³⁾	254	56	310	310	210	210	254	55	287.5	86	108	185.5	141.5	20	42	32	M16	M12
180 ⁴⁾	279	65.5	340	310	210	241	279	58	316	88	121	185.5	141.5	25	48	32	M16	M12
180 ⁵⁾	279	65.5	340	310	210	241	279	58	316	88	121	226.5	182.5	25	48	32	M16	M12
200 ⁶⁾	318	64	380	360	210	267	305	98	365	98	133	218	180	30	55	32	M20	M12
200 ⁷⁾	318	64	380	360	210	267	305	98	365	98	133	238	200	30	55	32	M20	M12

Motor size	E ⁹⁾	EA	EG	EH	F	FA	G	GA	GB	GC	H	HA	HB	HC	HD	HE	K	L
160 ³⁾	110	80	36	28	12	10	37	45	27	35	160	20	325	370	130	15	602.5	
180 ⁴⁾	110	80	36	28	14	10	42.5	51.5	27	35	180	20	345	390	130	15	602.5	
180 ⁵⁾	110	80	36	28	14	10	42.5	51.5	27	35	180	20	345	390	130	15	643.5	
200 ⁶⁾	110	80	42	28	16	10	49	59	27	35	200	25	380	425	145	18	711.5	
200 ⁷⁾	110	80	42	28	16	10	49	59	27	35	200	25	380	425	145	18	732	

Motor size	LA	LB	LC	M	N	P	S	T	UB1 ²⁾	UB2 ²⁾	VA	VB	VC	VD	VE
160 ³⁾	16	492.5	693.5	300	250	350	19	5	2*M40	M16	89	210	79.5	134.5	171.5
180 ⁴⁾	20	492.5	693.5	300	250	350	19	5	2*M40	M16	89	210	79.5	134.5	171.5
180 ⁵⁾	20	533.5	734	300	250	350	19	5	2*M40	M16	89	210	79.5	134.5	171.5
200 ⁶⁾	20	601.5	801.5	350	300	400	19	5	2*M40	M16	109	210	79.5	134.5	171.5
200 ⁷⁾	20	622.0	821.5	350	300	400	19	5	2*M40	M16	109	210	79.5	134.5	171.5

Tolerances

A, B	ISO js14
C, CA	+0 -2
DA32	ISO k6
D45-48	ISO k6
D55	ISO m6
F, FA	ISO h9
H	+0 -0.5
N	ISO j6

²⁾ Knockout openings.

³⁾ MA-2, M-2, L-2, M-4, L-4

⁴⁾ M-2, M-4

⁵⁾ L-4

⁶⁾ LA-2

⁷⁾ L-2, L-4

⁸⁾ Shoulder of shaft extension and contact surface of flange are in the same plane.

⁹⁾ 160 M, 180 M: B' not acc. to IEC.

160 L, 180 L, 200 LA: B not acc. to IEC.

Above table gives the main dimensions in mm.

For detailed drawings please see our web-pages 'www.abb.com/motors&drives' or contact us.

General purpose aluminum motors

Dimension drawings

M2AA 225-250

Foot-mounted motor; IM B3 (IM 1001), IM 1002

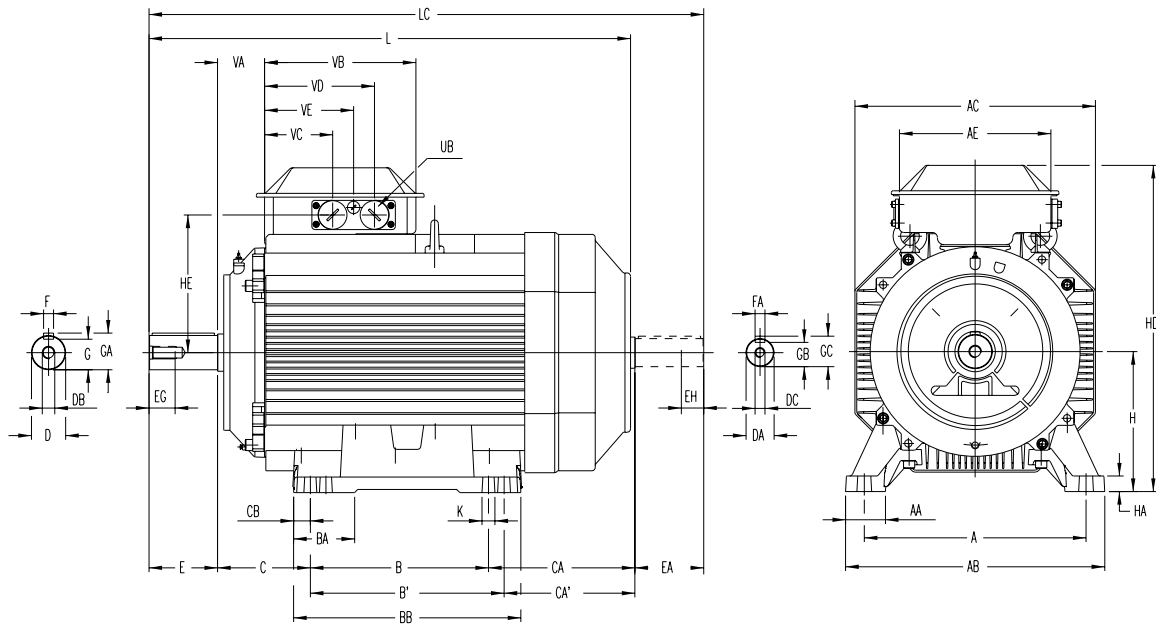

Dimension AD and HD refer to side mounted terminal box, see page 73.

IM B3 (IM 1001), IM 1002

Motor size	A	AA	AB	AC	AE	B ⁵⁾	B'	BA	BB	C	CA	CA'	CB	D	DA	DB	DC	E	EA	EG	EH
225 M-2	356	64	416	386	243	286 ⁷⁾	311	81.5	365	149	238	213	27	55	45	M20	M16	110	110	42	36
225 S-4	356	64	416	386	243	286	311 ⁸⁾	81.5	365	149	238	213	27	60	45	M20	M16	140	110	42	36
225 M-4	356	64	416	386	243	286 ⁷⁾	311	81.5	365	149	278	253	27	60	45	M20	M16	140	110	42	36
250 M-2	406	76	472	425	243	311 ⁷⁾	349	99.5	409	168	256	218	30	60	55	M20	M20	140	110	42	42
250 M-4	406	76	472	425	243	311 ⁷⁾	349	99.5	409	168	256	218	30	65	55	M20	M20	140	110	42	42

Motor size	F	FA	G	GA	GB	GC	H	HA	HD	HE	K	L	LC	UB ²⁾	VA	VB	VC ³⁾	VC ⁴⁾	VD ³⁾	VD ⁴⁾
225 M-2	16	14	49	59	39.5	48.5	225	25	525.5	221	18	773	893	2xFL 13	75.5	243	109.5	81.5	176.5	171.5
225 S-4	18	14	53	64	39.5	48.5	225	25	525.5	221	18	803	923	2xFL 13	75.5	243	109.5	81.5	176.5	171.5
225 M-4	18	14	53	64	39.5	48.5	225	25	525.5	221	18	843	963	2xFL 13	75.5	243	109.5	81.5	176.5	171.5
250 M-2	18	16	53	64	49	59	250	40	571	241	22	866	985	2xFL 13	93.5	243	109.5	81.5	176.5	171.5
250 M-4	18	16	58	69	49	59	250	40	571	241	22	866	985	2xFL 13	93.5	243	109.5	81.5	176.5	171.5

Motor size	VE ³⁾	VE ⁴⁾
225 M-2	143	126.5
225 S-4	143	126.5
225 M-4	143	126.5
250 M-2	143	126.5
250 M-4	143	126.5

Tolerances
 A, B ISO js14
 C, CA 0 +2
 DA 45 ISO k6
 D, DA 55-65 ISO m6
 F, FA ISO h9
 H +0 - 0.5

- ²⁾ Flange opening is provided with pipe flange FL 13, with tapped lead-in holes plugged with sealing plugs.
Single- and two-speed motors: 2 x M40 + M16.
Motors for 230 V 50 Hz have pipe flange FL 21 and 2 x M63 + M16.
- ³⁾ For flange opening FL 13: 2 x M40 + M16.
- ⁴⁾ For extra large terminal box with flange opening FL 21: 2 x M63 + M16.
- ⁵⁾ Basic design only.
- ⁶⁾ Dimension CB = 30 for high output design.
- ⁷⁾ Not according to IEC for M.
- ⁸⁾ Not according to IEC for S.

Above table gives the main dimensions in mm.
 For detailed drawings please see our web-pages
www.abb.com/motors&drives or contact us.

General purpose aluminum motors

M2AA 225-250

Dimension drawings

Flange-mounted motor; IM B5 (IM 3001), IM 3002

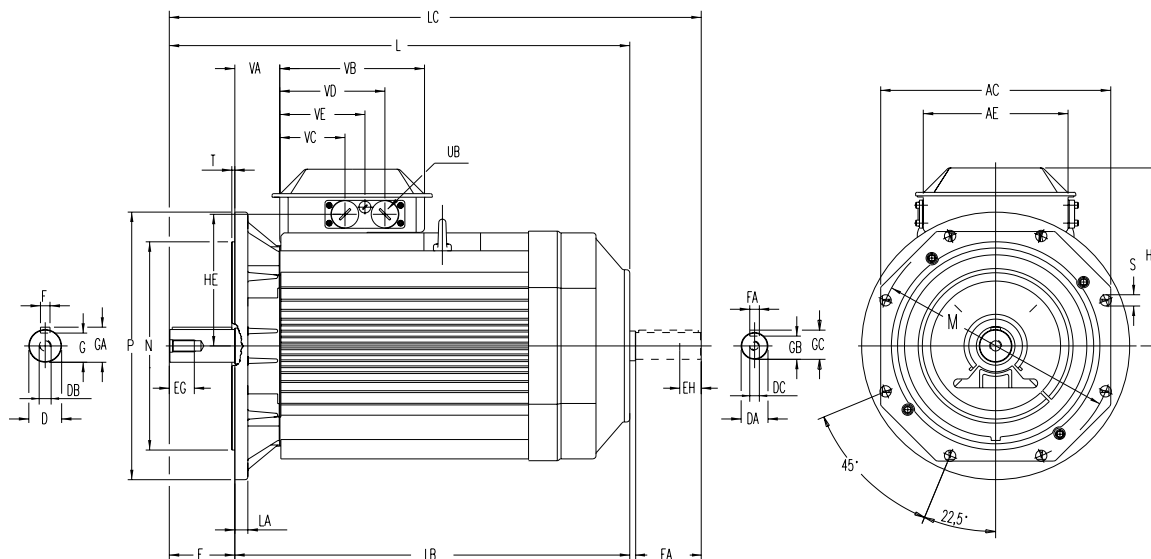

IM B5 (IM 3001), IM 3002

Motor size	AC	AE	D	DA	DB	DC	E ²⁾	EA	EG	EH	F	FA	G	GA	GB	GC	HB	HE
225 M-2	386	243	55	45	M20	M16	110	110	42	36	16	14	49	59	39.5	48.5	300.5	221
225 S-4	386	243	60	45	M20	M16	140	110	42	36	18	14	53	64	39.5	48.5	300.5	221
225 M-4	386	243	60	45	M20	M16	140	110	42	36	18	14	53	64	39.5	48.5	300.5	221
250 M-2	425	243	60	55	M20	M20	140	110	42	42	18	16	53	64	49	59	321	241
250 M-4	425	243	65	55	M20	M20	140	110	42	42	18	16	58	69	49	59	321	241

Motor size	L	LA	LB	LC	M	N	P	S	T	UB ³⁾	VA	VB	VC ⁴⁾	VC ⁵⁾	VD ⁴⁾	VD ⁵⁾	VE ⁴⁾	VE ⁵⁾
225 M-2	773	22	663	893	400	350	450	19	5	2 x FL 13	75.5	243	109.5	81.5	176.5	171.5	143	126.5
225 S-4	803	22	663	923	400	350	450	19	5	2 x FL 13	75.5	243	109.5	81.5	176.5	171.5	143	126.5
225 M-4	843	22	703	963	400	350	450	19	5	2 x FL 13	75.5	243	109.5	81.5	176.5	171.5	143	126.5
250 M-2	866	22	725	985	500	450	550	19	5	2 x FL 13	93.5	243	109.5	81.5	176.5	171.5	143	126.5
250 M-4	866	22	725	985	500	450	550	19	5	2 x FL 13	93.5	243	109.5	81.5	176.5	171.5	143	126.5

Tolerances

DA 45 ISO k6
D, DA 55-60 ISO m6
F, FA ISO h9
N ISO js6

²⁾ Shoulder of shaft extension and contact surface of flange are in the same plane.

³⁾ Flange opening is provided with pipe flange FL 13, with tapped lead-in holes plugged with sealing plugs.
Single- and two-speed motors: 2 x M40 + M16.
Motors for 230 V 50 Hz have pipe flange FL 21 and 2 x M63 + M16.

⁴⁾ For flange opening FL 13: 2 x M40 + M16.

⁵⁾ For extra large terminal box with flange opening FL 21: 2 x M63 + M16.

Above table gives the main dimensions in mm.
For detailed drawings please see our web-pages
www.abb.com/motors&drives or contact us.

General purpose aluminum motors

Dimension drawings

M2AA 225-250

Foot- and flange-mounted motor; IM B35 (IM 2001), IM 2002

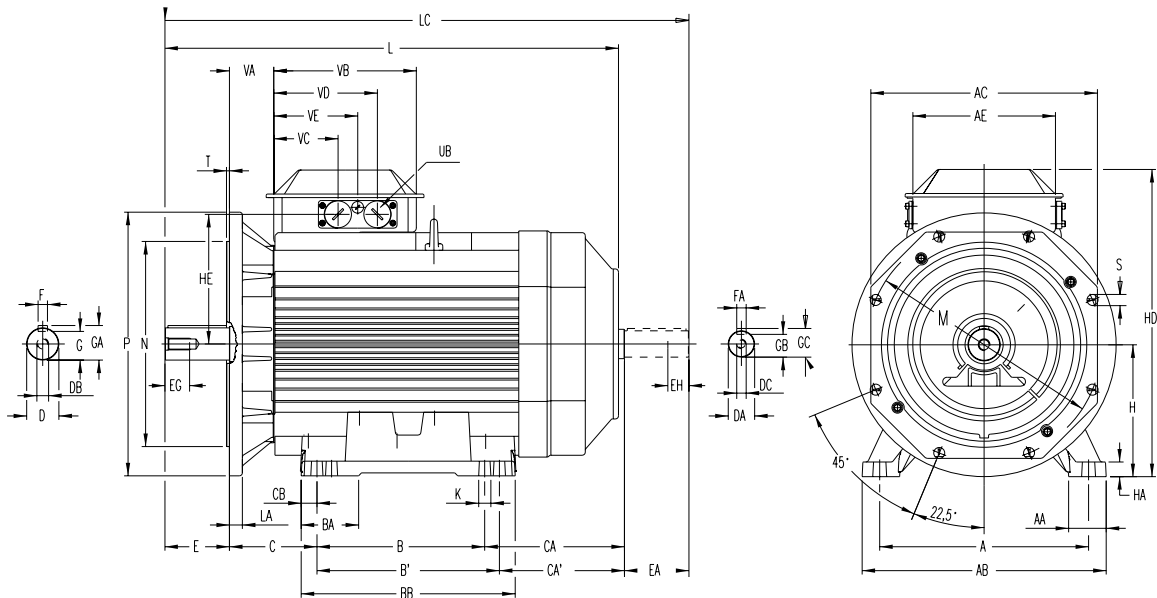

IM B35 (IM 2001), IM 2002

Motor size	A	AA	AB	AC	AE	B	B'	BA	BB	C	CA	CA'	CB	D	DA	DB	DC	E ⁵⁾	EA	EG	EH	F	FA	G	GA
225 M-2	356	64	416	386	243	286	311	81.5	365	149	238	213	27	55	45	M20	M16	110	110	42	36	16	14	49	59
225 S-4	356	64	416	386	243	286	311	81.5	365	149	238	213	27	60	45	M20	M16	140	110	42	36	18	14	53	64
225 M-4	356	64	416	386	243	286	311	81.5	365	149	278	253	27	60	45	M20	M16	140	110	42	36	18	14	53	64
250 M-2	406	76	472	425	243	311	349	99.5	409	168	256	218	30	60	55	M20	M20	140	110	42	42	18	16	53	64
250 M-4	406	76	472	425	243	311	349	99.5	409	168	256	218	30	65	55	M20	M20	140	110	42	42	18	16	58	69

Motor size	GB	GC	H	HA	HD	HE	K	L	LA	LB	LC	M	N ¹⁾	P	S	T	UB ²⁾	VA	VB	VC ³⁾	VC ⁴⁾	VD ³⁾	VD ⁴⁾
225 M-2	39.5	48.5	225	25	525.5	221	18	773	22	663	893	400	350	450	19	5	2 x FL 13	75.5	243	109.5	81.5	176.5	171.5
225 S-4	39.5	48.5	225	25	525.5	221	18	803	22	663	923	400	350	450	19	5	2 x FL 13	75.5	243	109.5	81.5	176.5	171.5
225 M-4	39.5	48.5	225	25	525.5	221	18	843	22	703	963	400	350	450	19	5	2 x FL 13	75.5	243	109.5	81.5	176.5	171.5
250 M-2	49	59	250	40	571	241	22	866	22	725	985	500	450	550	19	5	2 x FL 13	93.5	243	109.5	81.5	176.5	171.5
250 M-4	49	59	250	40	571	241	22	866	22	725	985	500	450	550	19	5	2 x FL 13	93.5	243	109.5	81.5	176.5	171.5

Motor size	VE ³⁾	VE ⁴⁾
225 M-2	143	126.5
225 S-4	143	126.5
225 M-4	143	126.5
250 M-2	143	126.5
250 M-4	143	126.5

Tolerances
 A, B ISO js14
 C, CA 0 +2
 D 44 ISO k6
 D, DA 55-65 ISO m6
 F, FA ISO h9
 H +0 -0.5

²⁾ Flange opening is provided with pipe flange FL 13, with tapped lead-in holes plugged with sealing plugs, 2 x M40 + M16.

³⁾ For flange opening FL 13: 2 x M40 + M16.

⁴⁾ For extra large terminal box with flange opening FL 21: 2 x M63 + M16.

⁵⁾ Shoulder of shaft extension and contact surface of flange are in the same plane.

Above table gives the main dimensions in mm.
 For detailed drawings please see our web-pages
www.abb.com/motors&drives or contact us.

General purpose aluminum motors

M3AA 160-180

Dimension drawings

Foot-mounted motor; IM B3 (IM 1001), IM 1002

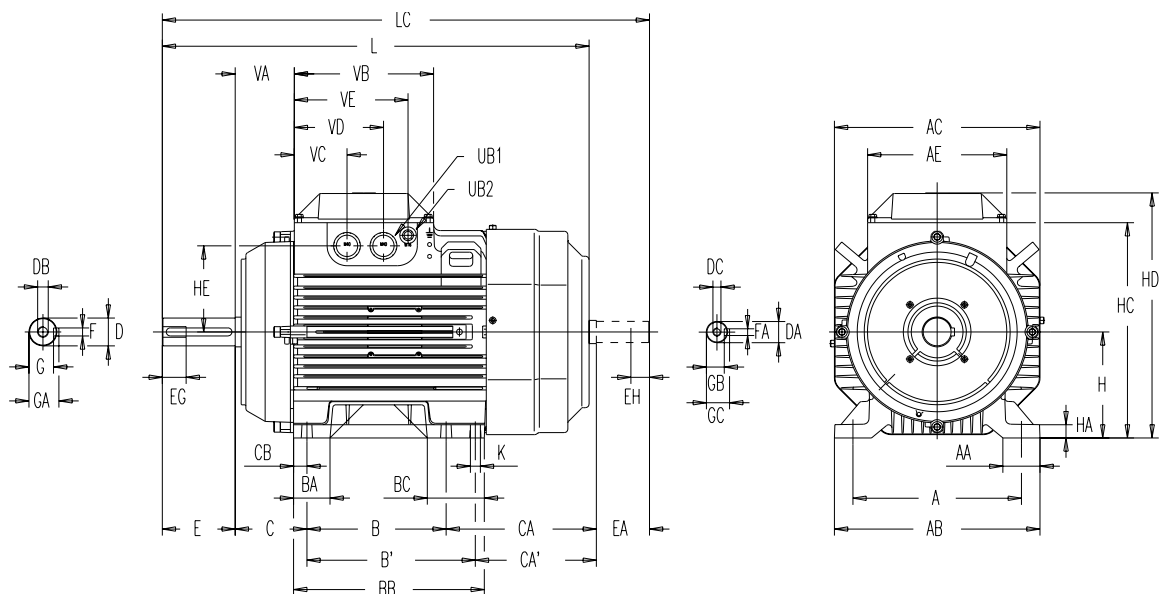

IM B3 (IM 1001), IM 1002

Motor size	A	AA	AB	AC	AE	B ⁷⁾	B' ⁷⁾	BA	BB	BC	C	CA	CA'	CB	D	DA	DB	DC	E	EA	EG	EH	F
160 ³⁾	254	56	310	310	210	210	254	55	287.5	86	108	185.5	141.5	20	42	32	M16	M12	110	80	36	28	12
160 ⁴⁾	254	56	310	310	210	210	254	55	287.5	86	108	226.5	182.5	20	42	32	M16	M12	110	80	36	28	12
180 ⁵⁾	279	65.5	340	360	210	241	279	58	316	88	121	218	180	25	48	32	M16	M12	110	80	36	28	14
180 ⁶⁾	279	65.5	340	360	210	241	279	58	316	88	121	238	200	25	48	32	M16	M12	110	80	36	28	14

Motor size	FA	G	GA	GB	GC	H	HA	HC	HD	HE	K	L	LC	UB1 ²⁾	UB2 ²⁾	VA	VB	VC	VD	VE
160 ³⁾	10	37	45	27	35	160	20	325	370	130	15	602.5	693.5	2*M40	M16	89	210	84.5	134.5	167.5
160 ⁴⁾	10	37	45	27	35	160	20	325	370	130	15	643.5	734.5	2*M40	M16	89	210	84.5	134.5	167.5
180 ⁵⁾	10	42.5	51.5	27	35	180	20	360	405	145	15	680	770	2*M40	M16	77.5	210	84.5	134.5	167.5
180 ⁶⁾	10	42.5	51.5	27	35	180	20	360	405	145	15	700.5	790	2*M40	M16	77.5	210	84.5	134.5	167.5

Tolerances

A, B ISO js14
 C, CA +2 -2
 D, DA ISO k6
 F, FA ISO h9
 H +0 -0.5

²⁾ Knockout openings.

³⁾ M-2, MA-2, M-4, M-6, M-8, MA-8, L-2, L-4, L-6, MA-2/4, M-2/4, L-2/4, M-4/6, M-4/8, LB-2, LB-4

⁴⁾ L-8, L-4/6, L-4/8, LB-6, LB-8

⁵⁾ M-2, M-4, L-6, L-8, M-2/4, M-4/6, M-4/8, LB-2

⁶⁾ L-4, L-2/4, L-4/6, L-4/8, LB-4, LB-6, LB-8

⁷⁾ 160 M, 180 M: B' not acc. to IEC
 160 L, 180 L: B not acc. to IEC

Above table gives the main dimensions in mm.
 For detailed drawings please see our web-pages
 'www.abb.com/motors&drives' or contact us.

General purpose aluminum motors

Dimension drawings

M3AA 160-180

Flange-mounted motor; IM B5 (IM 3001), IM 3002

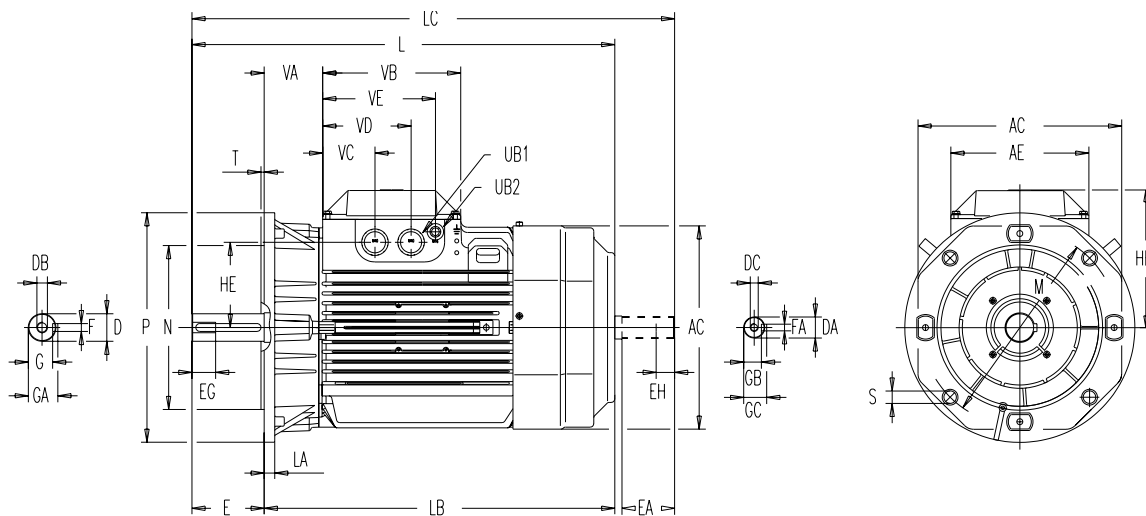

IM B5 (IM 3001), IM 3002

Motor size	AC	AE	D	DA	DB	DC	E ⁷⁾	EA	EG	EH	F	FA	G	GA	GB	GC	HB	HE
160 ³⁾	310	210	42	32	M16	M12	110	80	36	28	12	10	37	45	27	35	210	130
160 ⁴⁾	310	210	42	32	M16	M12	110	80	36	28	12	10	37	45	27	35	210	130
180 ⁵⁾	360	210	48	32	M16	M12	110	80	36	28	14	10	42.5	51.5	27	35	225	145
180 ⁶⁾	360	210	48	32	M16	M12	110	80	36	28	14	10	42.5	51.5	27	35	225	145

Motor size	L	LA	LB	LC	M	N	P	S	T	UB1 ²⁾	UB2 ²⁾	VA	VB	VC	VD	VE
160 ³⁾	602.5	16	492.5	693.5	300	250	350	19	5	2*M40	M16	89	210	79.5	134.5	171.5
160 ⁴⁾	643.5	16	533.5	734.5	300	250	350	19	5	2*M40	M16	89	210	79.5	134.5	171.5
180 ⁵⁾	680	21	570	770	300	250	350	19	5	2*M40	M16	77.5	210	79.5	134.5	171.5
180 ⁶⁾	700.5	21	590.5	790	300	250	350	19	5	2*M40	M16	77.5	210	79.5	134.5	171.5

Tolerances

D, DA ISO k6
F, FA ISO h9
N ISO j6

²⁾ Knockout openings.

³⁾ M-2, MA-2, M-4, M-6, M-8, MA-8, L-2, L-4, L-6, MA-2/4, M-2/4, L-2/4, M-4/6, M-4/8, LB-2, LB-4

⁴⁾ L-8, L-4/6, L-4/8, LB-6, LB-8

⁵⁾ M-2, M-4, L-6, L-8, M-2/4, M-4/6, M-4/8, LB-2

⁶⁾ L-4, L-2/4, L-4/6, L-4/8, LB-4, LB-6, LB-8

⁷⁾ Shoulder of shaft extension and contact surface of flange are in the same plane.

Above table gives the main dimensions in mm.
For detailed drawings please see our web-pages
'www.abb.com/motors&drives' or contact us.

General purpose aluminum motors

M3AA 160-180

Dimension drawings

Foot- and flange-mounted motor; IM B35 (IM 2001), IM 2002

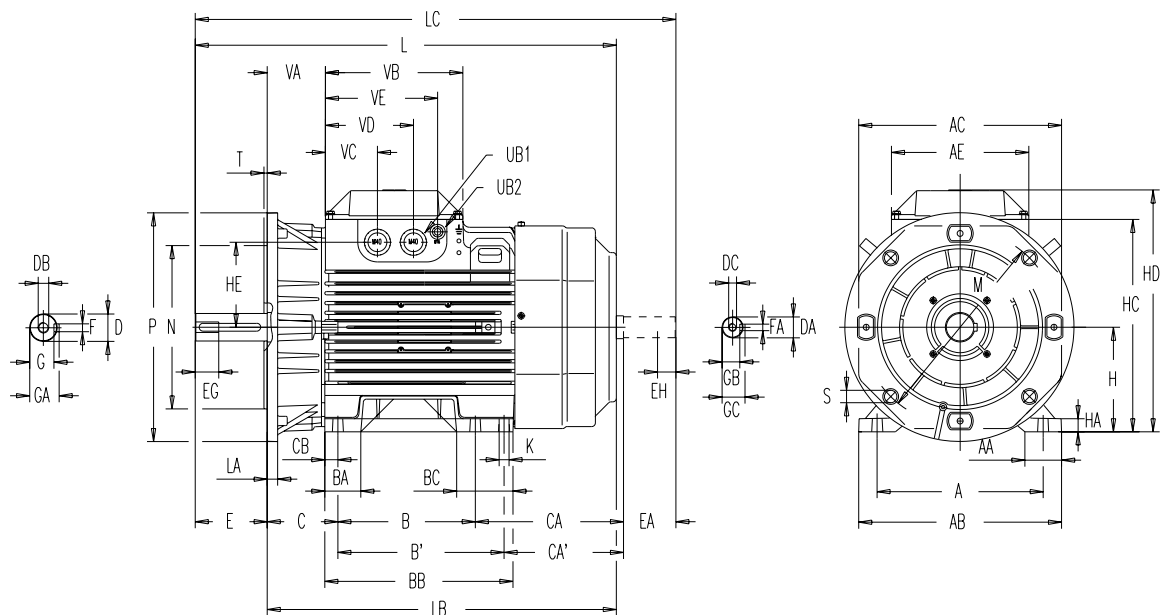

IM B35 (IM 2001), IM 2002

Motor size	A	AA	AB	AC	AE	B ⁸⁾	B' ⁸⁾	BA	BB	BC	C	CA	CA'	CB	D	DA	DB	DC
160 ³⁾	254	56	310	310	210	210	254	55	287.5	86	108	185.5	141.5	20	42	32	M16	M12
160 ⁴⁾	254	56	310	310	210	210	254	55	287.5	86	108	226.5	182.5	20	42	32	M16	M12
180 ⁵⁾	279	65.5	340	360	210	241	279	58	316	88	121	218	180	25	48	32	M16	M12
180 ⁶⁾	279	65.5	340	360	210	241	279	58	316	88	121	238	200	25	48	32	M16	M12

Motor size	E ⁷⁾	EA	EG	EH	F	FA	G	GA	GB	GC	H	HA	HB	HC	HD	HE	K	L
160 ³⁾	110	80	36	28	12	10	37	45	27	35	160	20	210	325	370	130	15	602.5
160 ⁴⁾	110	80	36	28	12	10	37	45	27	35	160	20	210	325	370	130	15	643.5
180 ⁵⁾	110	80	36	28	14	10	42.5	51.5	27	35	180	20	225	360	405	145	15	680
180 ⁶⁾	110	80	36	28	14	10	42.5	51.5	27	35	180	20	225	360	405	145	15	700.5

Motor size	LA	LB	LC	M	N	P	S	T	UB1 ²⁾	UB2 ²⁾	VA	VB	VC	VD	VE
160 ³⁾	16	492.5	693.5	300	250	350	19	5	2*M40	M16	89	210	79.5	134.5	171.5
160 ⁴⁾	16	533.5	734.5	300	250	350	19	5	2*M40	M16	89	210	79.5	134.5	171.5
180 ⁵⁾	21	570	770	300	250	350	19	5	2*M40	M16	77.5	210	79.5	134.5	171.5
180 ⁶⁾	21	590.5	790	300	250	350	19	5	2*M40	M16	77.5	210	79.5	134.5	171.5

Tolerances

A, B ISO js14
 C, CA +0 -2
 D, DA ISO k6
 F, FA ISO h9
 H +0 -0.5
 N ISO j6

²⁾ Knockout openings.

³⁾ M-2, MA-2, M-4, M-6, M-8, MA-8, L-2, L-4, L-6, MA-2/4, M-2/4, L-2/4, M-4/6, M-4/8, LB-2, LB-4.

⁴⁾ L-8, L-4/6, L-4/8, LB-6, LB-8.

⁵⁾ M-2, M-4, L-6, L-8, M-2/4, M-4/6, M-4/8, LB-2.

⁶⁾ L-4, L-2/4, L-4/6, L-4/8, LB-4, LB-6, LB-8.

⁷⁾ Shoulder of shaft extension and contact surface of flange are in the same plan.

⁸⁾ 160 M, 180 M: B' not acc. to IEC.

160 L, 180 L: B not acc. to IEC.

Above table gives the main dimensions in mm.

For detailed drawings please see our web-pages
 'www.abb.com/motors&drives' or contact us.

General purpose aluminum motors

M3AA 200-225

Dimension drawings

Foot-mounted motor; IM B3 (IM 1001), IM 1002

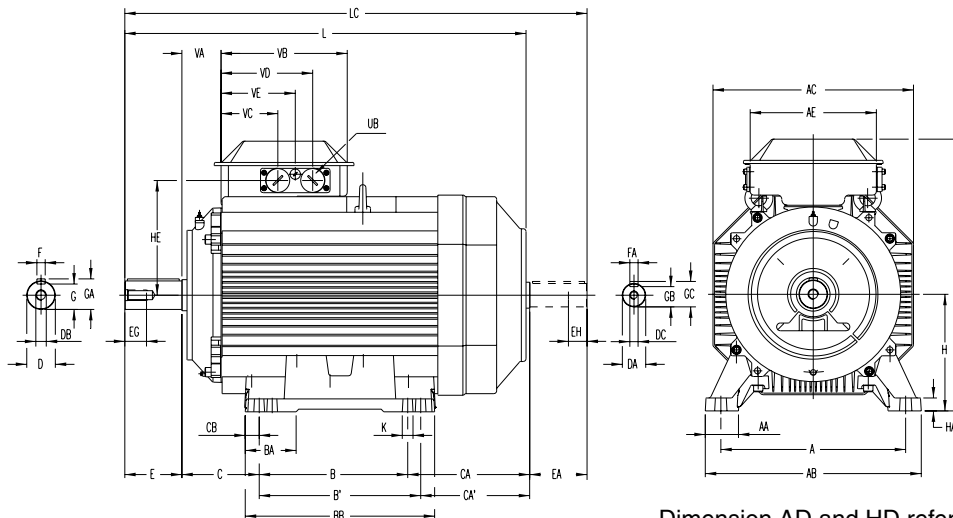

Dimension AD and HD refer to side mounted terminal box, see page 73.

IM B3 (IM 1001), IM 1002

Motor size	A	AA	AB	AC	AE	B	B'	BA	BB	C	CA	CA'	CB	D	DA	DB	DC	E ^{D)}	EA	EG	EH	F	FA
200 ¹⁾	318	64	380	386	243	267	305	98	365	133	273	235	30	55	45	M20	M16	110	110	42	36	16	14
200 ²⁾	318	64	380	386	243	267	305	98	365	133	313	275	30	55	45	M20	M16	110	110	42	36	16	14
225 ³⁾	356	69	418	425	243	286	311	84	360	149	300	275	24.5	55	55	M20	M20	110	110	42	42	16	16
225 ⁴⁾	356	69	418	425	243	286	311	84	360	149	325	300	24.5	55	55	M20	M20	110	110	42	42	16	16
225 ⁵⁾	356	69	418	425	243	286	311	84	360	149	300	275	24.5	60	55	M20	M20	140	110	42	42	18	16
225 ⁶⁾	356	69	418	425	243	286	311	84	360	149	325	300	24.5	60	55	M20	M20	140	110	42	42	18	16

Motor size	G	GA	GB	GC	H	HA	HD ^{B)}	HD ^{C)}	HE	K	L	LC	UB ^{A)}	VA	VB	VC ^{B)}	VC ^{C)}	VD ^{B)}	VD ^{C)}	VE ^{B)}	VE ^{C)}
200 ¹⁾	49	59	39.5	48.5	200	25	500.5	533	224	18	774	893	2xFL13	75.5	243	109.5	81.5	176.5	171.5	143	126.5
200 ²⁾	49	59	39.5	48.5	200	25	500.5	533	224	18	814	933	2xFL13	75.5	243	109.5	81.5	176.5	171.5	143	126.5
225 ³⁾	49	59	49	59	225	25	546	578	244.5	18	836	955	2xFL13	93.5	243	109.5	81.5	176.5	171.5	143	126.5
225 ⁴⁾	49	59	49	59	225	25	546	578	244.5	18	861	980	2xFL13	93.5	243	109.5	81.5	176.5	171.5	143	126.5
225 ⁵⁾	53	64	49	59	225	25	546	578	244.5	18	866	985	2xFL13	93.5	243	109.5	81.5	176.5	171.5	143	126.5
225 ⁶⁾	53	64	49	59	225	25	546	578	244.5	18	891	1100	2xFL13	93.5	243	109.5	81.5	176.5	171.5	143	126.5

Tolerances

A, B	ISO js14
C, CA	+0 -2
D 55-65	ISO m6
DA 45-55	ISO k6
F, FA	ISO h9
H	+0 -0.5
N	ISO j6

- 1) all 200 excl²⁾
- 2) MLD-2, MLC-4
- 3) SMB-2, SMC-2, SM_-2/4
- 4) SMD-2,
- 5) all 225 excl^{3) 4) 6)}
- 6) SMD-4

- A) Flange opening is provided with pipe flange FL 13, with tapped lead-in holes plugged with sealing plugs 2 x M40 + M16. Motors for 230VD 50Hz have pipe flange FL21 and 2 x M63 + M16
- B) For flange opening FL13: 2 x M40 + M16
- C) For extra large flange opening FL21: 2 x M63 + M16
- D) For IM B5 and IM B35: Shoulder of shaft extension and contact surface of flange are in the same plane.

Above table gives the main dimensions in mm.

For detailed drawings please see our web-pages 'www.abb.com/motors&drives' or contact us.

General purpose aluminum motors

Dimension drawings

M3AA 200-225

Flange-mounted motor; IM B5 (IM 3001), IM 3002

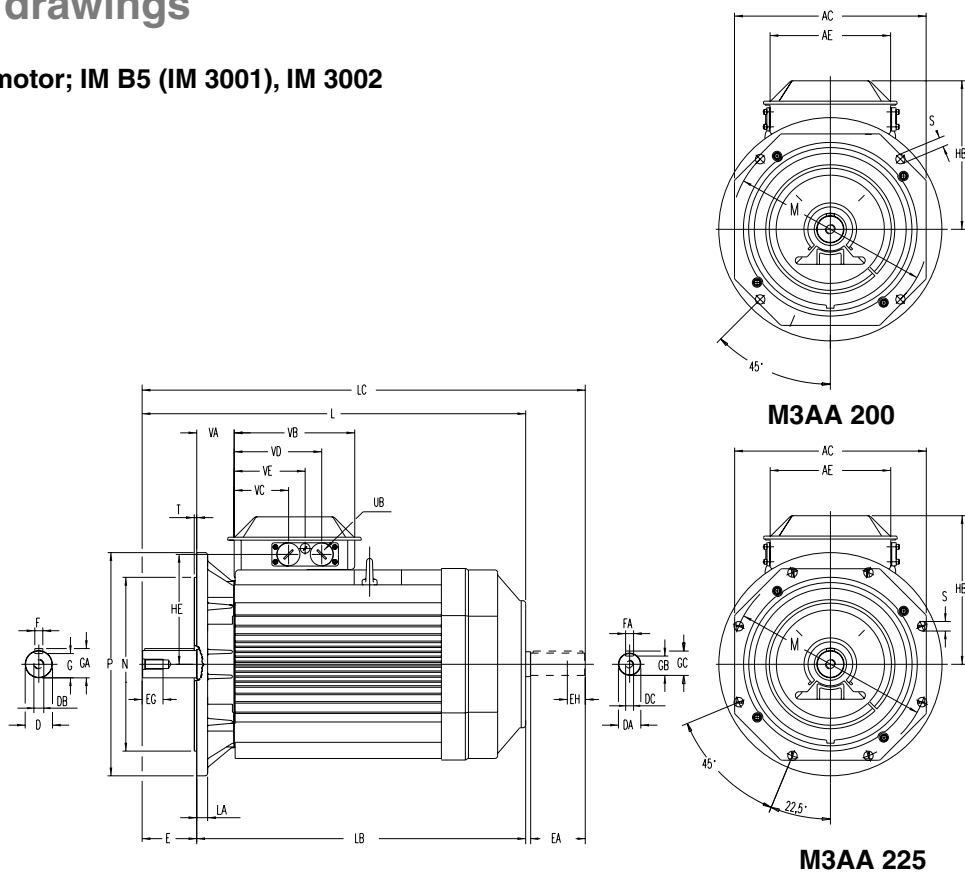

IM B5 (IM 3001), IM 3002

Motor size	AC	AE	D	DA	DB	DC	E ^{D)}	EA	EG	EH	F	FA	G	GA	GB	GC	HB ^{B)}	HB ^{C)}	HE
200 ¹⁾	386	243	55	45	M20	M16	110	110	42	36	16	14	49	59	39.5	48.5	301	333	224
200 ²⁾	386	243	55	45	M20	M16	110	110	42	36	16	14	49	59	39.5	48.5	301	333	224
225 ³⁾	425	243	55	55	M20	M20	110	110	42	42	16	16	49	59	49	59	321	353	244.5
225 ⁴⁾	425	243	55	55	M20	M20	110	110	42	42	16	16	49	59	49	59	321	353	244.5
225 ⁵⁾	425	243	60	55	M20	M20	140	110	42	42	16	16	53	64	49	59	321	353	244.5
225 ⁶⁾	425	243	60	55	M20	M20	140	110	42	42	16	16	53	64	49	59	321	353	244.5

Motor size	L	LA	LB	LC	M	N	P	S	T	UB ^{A)}	VA	VB	VC ^{B)}	VC ^{C)}	VD ^{B)}	VD ^{C)}	VE ^{B)}	VE ^{C)}
200 ¹⁾	774	20	664	893	350	300	400	19	5	2xFL13	75.5	243	109.5	81.5	176.5	171.5	143	126.5
200 ²⁾	814	20	704	933	350	300	400	19	5	2xFL13	75.5	243	109.5	81.5	176.5	171.5	143	126.5
225 ³⁾	836	22	726	955	400	350	450	19	5	2xFL13	93.5	243	109.5	81.5	176.5	171.5	143	126.5
225 ⁴⁾	861	22	751	980	400	350	450	19	5	2xFL13	93.5	243	109.5	81.5	176.5	171.5	143	126.5
225 ⁵⁾	866	22	726	985	400	350	450	19	5	2xFL13	93.5	243	109.5	81.5	176.5	171.5	143	126.5
225 ⁶⁾	891	22	751	1100	400	350	450	19	5	2xFL13	93.5	243	109.5	81.5	176.5	171.5	143	126.5

Tolerances

A, B	ISO js14
C, CA	+0 -2
D 55-65	ISO m6
DA 45-55	ISO k6
F, FA	ISO h9
H	+0 -0.5
N	ISO j6

- 1) all 200 excl 2)
- 2) MLD-2, MLC-4
- 3) SMB-2, SMC-2, SM_-2/4
- 4) SMD-2,
- 5) all 225 excl 3) 4) 6)
- 6) SMD-4

- A) Flange opening is provided with pipe flange FL 13, with tapped lead-in holes plugged with sealing plugs 2 x M40 + M16. Motors for 230VD 50Hz have pipe flange FL21 and 2 x M63 + M16
- B) For flange opening FL13: 2 x M40 + M16
- C) For extra large flange opening FL21: 2 x M63 + M16
- D) For IM B5 and IM B35: Shoulder of shaft extension and contact surface of flange are in the same plane.

Above table gives the main dimensions in mm.
For detailed drawings please see our web-pages
'www.abb.com/motors&drives' or contact us.

General purpose aluminum motors

Dimension drawings

Foot- and flange-mounted motor; IM B35 (IM 2001), IM 2002

M3AA 200-225

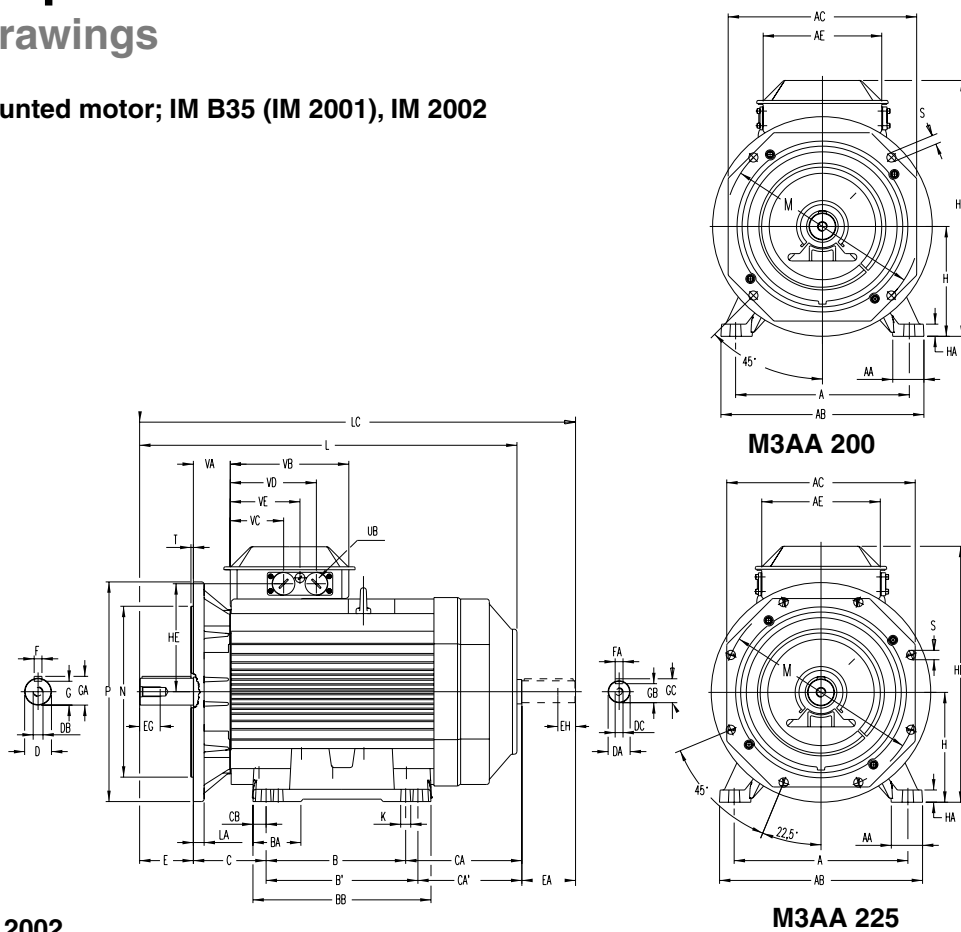

IM B35 (IM 2001), IM 2002

Motor size	A	AA	AB	AC	AE	B	B'	BA	BB	C	CA	CA'	CB	D	DA	DB	DC	E ^{D)}	EA	EG	EH	F	FA	G	GA	GB	GC
200 ¹⁾	318	64	380	386	243	267	305	98	365	133	273	235	30	55	45	M20	M16	110	110	42	36	16	14	49	59	39.5	48.5
200 ²⁾	318	64	380	386	243	267	305	98	365	133	313	275	30	55	45	M20	M16	110	110	42	36	16	14	49	59	39.5	48.5
225 ³⁾	356	69	418	425	243	286	311	84	360	149	300	275	25	55	55	M20	M20	110	110	42	42	16	16	49	59	49	59
225 ⁴⁾	356	69	418	425	243	286	311	84	360	149	325	300	25	55	55	M20	M20	110	110	42	42	16	16	49	59	49	59
225 ⁵⁾	356	69	418	425	243	286	311	84	360	149	300	275	25	60	55	M20	M20	140	110	42	42	18	16	53	64	49	59
225 ⁶⁾	356	69	418	425	243	286	311	84	360	149	325	300	25	60	55	M20	M20	140	110	42	42	18	16	53	64	49	59

Motor size	H	HA	HB ^{B)}	HB ^{C)}	HD ^{B)}	HD ^{C)}	HE	K	L	LA	LB	LC	M	N	P	S	T	UB ^{A)}	VA	VB	VC ^{B)}	VC ^{C)}	VD ^{B)}	VD ^{C)}	VE ^{B)}	VE ^{C)}
200 ¹⁾	200	25	301	333	501	533	224	18	774	20	664	893	350	300	400	19	5	2xFL13	75.5	243	110	81.5	176.5	171.5	143	126.5
200 ²⁾	200	25	301	333	501	533	224	18	814	20	704	933	350	300	400	19	5	2xFL13	75.5	243	110	81.5	176.5	171.5	143	126.5
225 ³⁾	225	25	321	353	546	578	245	18	836	22	726	955	400	350	450	19	5	2xFL13	93.5	243	110	81.5	176.5	171.5	143	126.5
225 ⁴⁾	225	25	321	353	546	578	245	18	861	22	751	980	400	350	450	19	5	2xFL13	93.5	243	110	81.5	176.5	171.5	143	126.5
225 ⁵⁾	225	25	321	353	546	578	245	18	866	22	726	985	400	350	450	19	5	2xFL13	93.5	243	110	81.5	176.5	171.5	143	126.5
225 ⁶⁾	225	25	321	353	546	578	245	18	891	22	751	1100	400	350	450	19	5	2xFL13	93.5	243	110	81.5	176.5	171.5	143	126.5

Tolerances

A,B	ISO js14
C, CA	+0 -2
D 55-65	ISO m6
DA 45-55	ISO k6
F, FA	ISO h9
H	+0 -0.5
N	ISO j6

- ¹⁾ all 200 excl ²⁾
- ²⁾ MLD-2, MLC-4
- ³⁾ SMB-2, SMC-2, SM_-2/4
- ⁴⁾ SMD-2
- ⁵⁾ all 225 excl ³⁾ ⁴⁾ ⁶⁾
- ⁶⁾ SMD-4

- ^{A)} Flange opening is provided with pipe flange FL 13, with tapped lead-in holes plugged with sealing plugs 2 x M40 + M16. Motors for 230VD 50Hz have pipe flange FL21 and 2 x M63 + M16
- ^{B)} For flange opening FL13: 2 x M40 + M16
- ^{C)} For extra large flange opening FL21: 2 x M63 + M16
- ^{D)} For IM B5 and IM B35: Shoulder of shaft extension and contact surface of flange are in the same plane.

Above table gives the main dimensions in mm.
For detailed drawings please see our web-pages
www.abb.com/motors&drives or contact us.

General purpose aluminum motors

M3AA 250-280

Dimension drawings

Foot-mounted motor; IM B3 (IM 1001), IM 1002

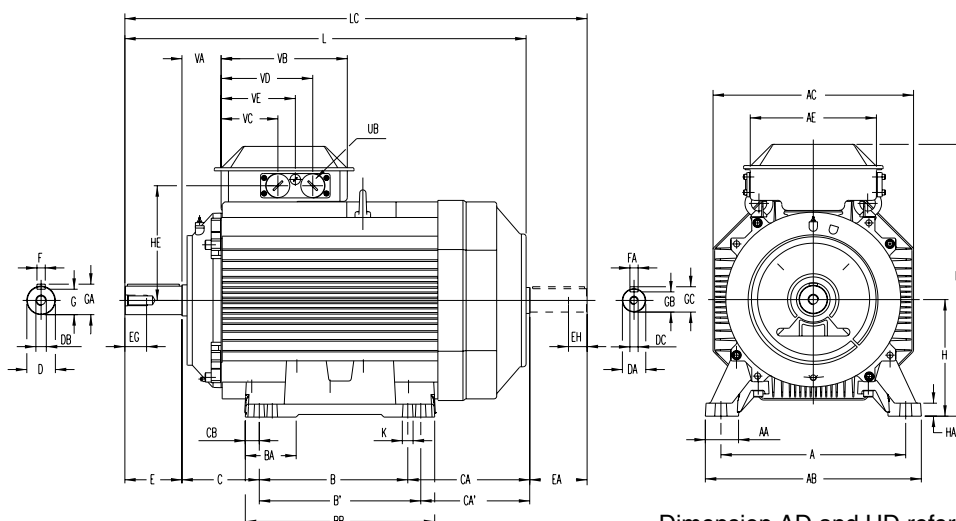

Dimension AD and HD refer to side mounted terminal box, see page 73.

IM B3 (IM 1001), IM 1002

Motor size	A	AA	AB	AC	AE	B	B'	BA	BB	C	CA	CA'	CB	D	DA	DB	DC	E ^{D)}	EA	EG	EH	F	FA
250 ¹⁾	406	78	474	471	243	311	349	94.5	409	168	263	225	40	60	55	M20	M20	140	110	42	42	18	16
250 ²⁾	406	78	474	471	243	311	349	94.5	409	168	288	250	40	60	55	M20	M20	140	110	42	42	18	16
250 ³⁾	406	78	474	471	243	311	349	94.5	409	168	263	225	30	65	55	M20	M20	140	110	42	42	18	16
250 ⁴⁾	406	78	474	471	243	311	349	94.5	409	168	263	225	30	65	55	M20	M20	140	110	42	42	18	16
280 ⁵⁾	457	102.5	525	471	243	368	419	90.5	489	190	184	133	37.5	65	55	M20	M20	140	110	42	42	18	16
280 ⁶⁾	457	102.5	525	471	243	368	419	90.5	489	190	209	158	37.5	65	55	M20	M20	140	110	42	42	18	16
280 ⁷⁾	457	102.5	525	471	243	368	419	90.5	489	190	184	133	37.5	75	55	M20	M20	140	110	42	42	20	16
280 ⁸⁾	457	102.5	525	471	243	368	419	90.5	489	190	209	160	37.5	75	55	M20	M20	140	110	42	42	20	16

Motor size	G	GA	GB	GC	H	HA	HD ^{B)}	HD ^{C)}	HE	K	L	LC	UB ^{A)}	VA	VB	VC ^{B)}	VC ^{C)}	VD ^{B)}	VD ^{C)}	VE ^{B)}	VE ^{C)}
250 ¹⁾	53	64	49	59	250	40	594	626	267.5	22	875	992	2xFL13	93.5	243	109.5	81.5	176.5	171.5	143	126.5
250 ²⁾	53	64	49	59	250	40	594	626	267.5	22	900	1017	2xFL13	93.5	243	109.5	81.5	176.5	171.5	143	126.5
250 ³⁾	58	69	49	59	250	30	594	626	267.5	22	875	992	2xFL13	93.5	243	109.5	81.5	176.5	171.5	143	126.5
250 ⁴⁾	58	69	49	59	250	30	594	626	267.5	22	900	1017	2xFL13	93.5	243	109.5	81.5	176.5	171.5	143	126.5
280 ⁵⁾	58	69	49	59	280	40	-	656	283.5	24	875	992	2xFL21	93.5	243	-	76.5	-	166.5	-	121.5
280 ⁶⁾	58	69	49	59	280	40	-	656	283.5	24	900	1017	2xFL21	93.5	243	-	76.5	-	166.5	-	121.5
280 ⁷⁾	67.5	79.5	49	59	280	40	-	656	283.5	24	875	992	2xFL21	93.5	243	-	76.5	-	166.5	-	121.5
280 ⁸⁾	67.5	79.5	49	59	280	40	-	656	283.5	24	900	1017	2xFL21	93.5	243	-	76.5	-	166.5	-	121.5

Tolerances

A, B	ISO js14
C, CA	+0 -2
D 55-65	ISO m6
DA 45-55	ISO k6
F, FA	ISO h9
H	+0 -0.5
N	ISO j6

- 1) SMA-2, SMB-2, SMB2/4
- 2) SMC-2
- 3) all 250 excl 1) 2) 4)
- 4) SMC-4
- 5) SMA-2
- 6) SMB-2
- 7) SMA-4-8
- 8) SMB-4

- A) Flange opening is provided with pipe flange FL 13, with tapped lead-in holes plugged with sealing plugs 2 x M40 + M16. Motors for 230V 50Hz have pipe flange FL21 and 2 x M63 + M16
- B) For flange opening FL13: 2 x M40 + M16
- C) For extra large flange opening FL21: 2 x M63 + M16
- D) For IM B5 and IM B35: Shoulder of shaft extension and contact surface of flange are in the same plane.

Above table gives the main dimensions in mm.
For detailed drawings please see our web-pages
www.abb.com/motors&drives or contact us.

General purpose aluminum motors

M3AA 250-280

Dimension drawings

Flange-mounted motor; IM B5 (IM 3001), IM 3002

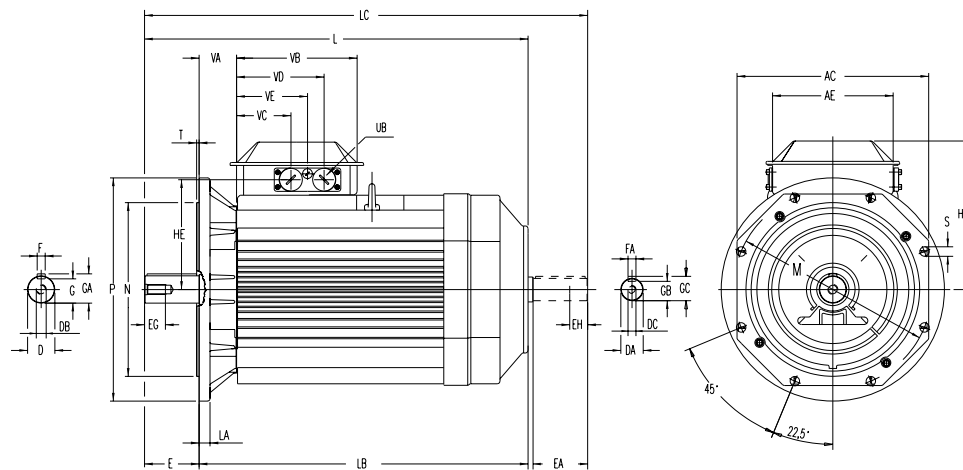

M3AA 250-280

IM B5 (IM 3001), IM 3002

Motor size	AC	AE	D	DA	DB	DC	E ^{D)}	EA	EG	EH	F	FA	G	GA	GB	GC	HB ^{B)}	HB ^{C)}	HE
250 ⁷⁾	471	243	60	55	M20	M20	140	110	42	42	18	16	53	64	49	59	344	376	267.5
250 ⁸⁾	471	243	60	55	M20	M20	140	110	42	42	18	16	53	64	49	59	344	376	267.5
250 ⁹⁾	471	243	65	55	M20	M20	140	110	42	42	18	16	58	69	49	59	344	376	267.5
250 ¹⁰⁾	471	243	65	55	M20	M20	140	110	42	42	18	16	58	69	49	59	344	376	267.5
280 ¹¹⁾	471	243	65	55	M20	M20	140	110	42	42	18	16	58	69	49	59	-	376	283.5
280 ¹²⁾	471	243	65	55	M20	M20	140	110	42	42	18	16	58	69	49	59	-	376	283.5
280 ¹³⁾	471	243	75	55	M20	M20	140	110	42	42	20	16	67.5	79.5	49	59	-	376	283.5
280 ¹⁴⁾	471	243	75	55	M20	M20	140	110	42	42	20	16	67.5	79.5	49	59	-	376	283.5

Motor size	L	LA	LB	LC	M	N	P	S	T	UB ^{A)}	VA	VB	VC ^{B)}	VC ^{C)}	VD ^{B)}	VD ^{C)}	VE ^{B)}	VE ^{C)}
250 ¹⁾	875	25	735	992	500	450	550	19	5	2xFL13	93.5	243	109.5	81.5	176.5	171.5	143	126.5
250 ²⁾	900	25	760	1017	500	450	550	19	5	2xFL13	93.5	243	109.5	81.5	176.5	171.5	143	126.5
250 ³⁾	875	25	735	992	500	450	550	19	5	2xFL13	93.5	243	109.5	81.5	176.5	171.5	143	126.5
250 ⁴⁾	900	25	760	1017	500	450	550	19	5	2xFL13	93.5	243	109.5	81.5	176.5	171.5	143	126.5
280 ⁵⁾	875	25	735	992	500	450	550	19	5	2xFL21	93.5	243	-	76.5	-	166.5	-	121.5
280 ⁶⁾	900	25	760	1017	500	450	550	19	5	2xFL21	93.5	243	-	76.5	-	166.5	-	121.5
280 ⁷⁾	875	25	735	992	500	450	550	19	5	2xFL21	93.5	243	-	76.5	-	166.5	-	121.5
280 ⁸⁾	900	25	760	1017	500	450	550	19	5	2xFL21	93.5	243	-	76.5	-	166.5	-	121.5

Tolerances

A, B	ISO js14
C, CA	+0 -2
D 55-65	ISO m6
DA 45-55	ISO k6
F, FA	ISO h9
H	+0 -0.5
N	ISO j6

- 1) SMA-2, SMB-2, SMB2/4
- 2) SMC-2
- 3) all 250 exc^{1) 2) 4)}
- 4) SMC-4
- 5) SMA-2
- 6) SMB-2
- 7) SMA-4-8
- 8) SMB-4

- A) Flange opening is provided with pipe flange FL 13, with tapped lead-in holes plugged with sealing plugs 2 x M40 + M16. Motors for 230VD 50Hz have pipe flange FL21 and 2 x M63 + M16
- B) For flange opening FL13: 2 x M40 + M16
- C) For extra large flange opening FL21: 2 x M63 + M16
- D) For IM B5 and IM B35: Shoulder of shaft extension and contact surface of flange are in the same plane.

Above table gives the main dimensions in mm.
For detailed drawings please see our web-pages
www.abb.com/motors&drives or contact us.

General purpose aluminum motors

M3AA 250-280

Dimension drawings

Foot- and flange-mounted motor; IM B35 (IM 2001), IM 2002

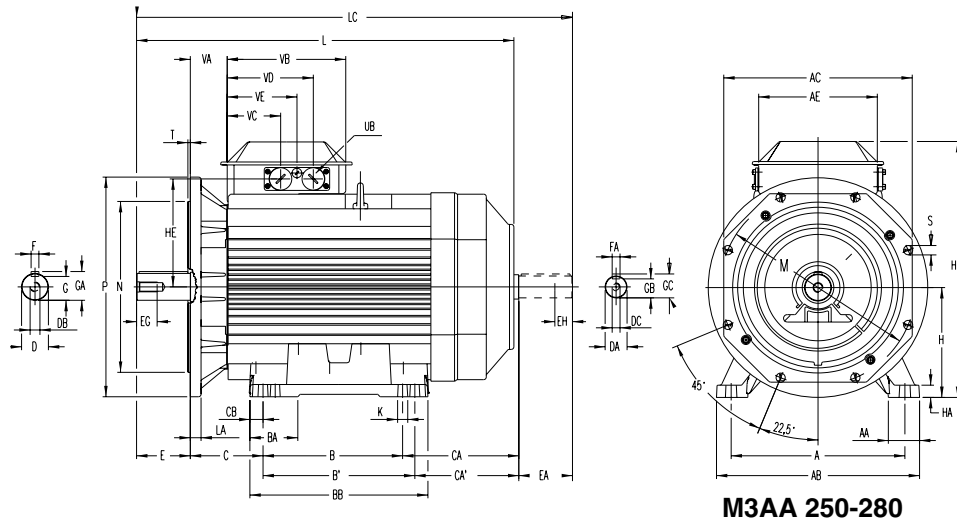

M3AA 250-280

IM B35 (IM 2001), IM 2002

Motor size	A	AA	AB	AC	AE	B	B'	BA	BB	C	CA	CA'	CB	D	DA	DB	DC	E ^{D)}	EA	EG	EH	F	FA	G	GA	GB	GC
250 ¹⁾	406	78	474	471	243	311	349	94.5	409	168	263	225	40	60	55	M20	M20	140	110	42	42	18	16	53	64	49	59
250 ²⁾	406	78	474	471	243	311	349	94.5	409	168	288	250	40	60	55	M20	M20	140	110	42	42	18	16	53	64	49	59
250 ³⁾	406	78	474	471	243	311	349	94.5	409	168	263	225	30	65	55	M20	M20	140	110	42	42	18	16	58	69	49	59
250 ⁴⁾	406	78	474	471	243	311	349	94.5	409	168	263	225	30	65	55	M20	M20	140	110	42	42	18	16	58	69	49	59
280 ⁵⁾	457	103	525	471	243	368	419	90.5	489	190	184	133	38	65	55	M20	M20	140	110	42	42	18	16	58	69	49	59
280 ⁶⁾	457	103	525	471	243	368	419	90.5	489	190	209	158	38	65	55	M20	M20	140	110	42	42	18	16	58	69	49	59
280 ⁷⁾	457	103	525	471	243	368	419	90.5	489	190	184	133	38	75	55	M20	M20	140	110	42	42	20	16	68	80	49	59
280 ⁸⁾	457	103	525	471	243	368	419	90.5	489	190	209	160	38	75	55	M20	M20	140	110	42	42	20	16	68	80	49	59

Motor size	H	HA	HB ^{B)}	HB ^{C)}	HD ^{B)}	HD ^{C)}	HE	K	L	LA	LB	LC	M	N	P	S	T	UB ^{A)}	VA	VB	VC ^{B)}	VC ^{C)}	VD ^{B)}	VD ^{C)}	VE ^{B)}	VE ^{C)}
250 ¹⁾	250	40	344	376	594	626	268	22	875	25	735	992	500	450	550	19	5	2xFL13	93.5	243	110	81.5	176.5	171.5	143	126.5
250 ²⁾	250	40	344	376	594	626	268	22	900	25	760	1017	500	450	550	19	5	2xFL13	93.5	243	110	81.5	176.5	171.5	143	126.5
250 ³⁾	250	30	344	376	594	626	268	22	875	25	735	992	500	450	550	19	5	2xFL13	93.5	243	110	81.5	176.5	171.5	143	126.5
250 ⁴⁾	250	30	344	376	594	626	268	22	900	25	760	1017	500	450	550	19	5	2xFL13	93.5	243	110	81.5	176.5	171.5	143	126.5
280 ⁵⁾	280	40	-	376	-	656	284	24	875	25	735	992	500	450	550	19	5	2xFL21	93.5	243	-	76.5	-	166.5	-	121.5
280 ⁶⁾	280	40	-	376	-	656	284	24	900	25	760	1017	500	450	550	19	5	2xFL21	93.5	243	-	76.5	-	166.5	-	121.5
280 ⁷⁾	280	40	-	376	-	656	284	24	875	25	735	992	500	450	550	19	5	2xFL21	93.5	243	-	76.5	-	166.5	-	121.5
280 ⁸⁾	280	40	-	376	-	656	284	24	900	25	760	1017	500	450	550	19	5	2xFL21	93.5	243	-	76.5	-	166.5	-	121.5

Tolerances

A, B	ISO js14
C, CA	+0 -2
D 55-65	ISO m6
DA 45-55	ISO k6
F, FA	ISO h9
H	+0 -0.5
N	ISO js6

- 1) SMA-2, SMB-2, SMB24
- 2) SMC-2
- 3) all 250 excl 1) 2) 4)
- 4) SMC-4
- 5) SMA-2
- 6) SMB-2
- 7) SMA-4-8
- 8) SMB-4

- A) Flange opening is provided with pipe flange FL 13, with tapped lead-in holes plugged with sealing plugs 2 x M40 + M16. Motors for 230VD 50Hz have pipe flange FL21 and 2 x M63 + M16
- B) For flange opening FL13: 2 x M40 + M16
- C) For extra large flange opening FL21: 2 x M63 + M16
- D) For IM B5 and IM B35: Shoulder of shaft extension and contact surface of flange are in the same plane.

Above table gives the main dimensions in mm.
For detailed drawings please see our web-pages 'www.abb.com/motors&drives' or contact us.

Dimensions for terminal box

Code 019 Larger than standard terminal box

Motor size	Dimensions			
	AD	HB	HD	HE
M2AA 225 S/M	-	332.5	557.5	240
M2AA 250 M	-	353	578	260.5
M3AA 200 ML.	332.5	332.5	603	240
M3AA 225 SM.	353	353	578	260.5
M3AA 250 SM.	376	376	626	283.5

Code 021 Terminal box on left-hand side seen from D end

Code 180 Terminal box on right-hand side seen from D end

Motor size	Dimensions	
	AD	HD
M2AA 225 - 250	On request	
M3AA 200 ML.	300.5	412.5
M3AA 225 SM.	321	452
M3AA 250 SM.	344	494
M3AA 280	376	524

Code 467 M2AA 160-250 on request.

Lower than standard terminal box without screw terminals and extended rubber connection cable 2 m.

Motor size	Dimensions		
	AD	HB	HD
112 M		123.5	235.5
132 S		141	273
132 M		141	273
160		211.5	371.5
180		226.5	406.5
200 ML.	248	248	448
225 SM.	269	269	494
250 SM.	292	292	542
280	292	292	572

Accessories

Protective roof and variable speed drives

Protective roof
Variant code 005

Tacho
Variant codes; 472, 473, 572 and 573

Separate cooling with or without tacho
Variant codes; 183, 474, 476, 477, 189, 574, 576 and 577

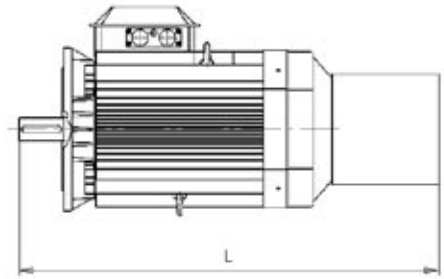
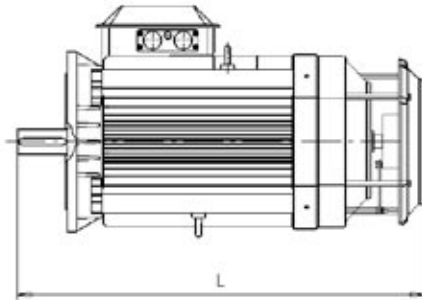
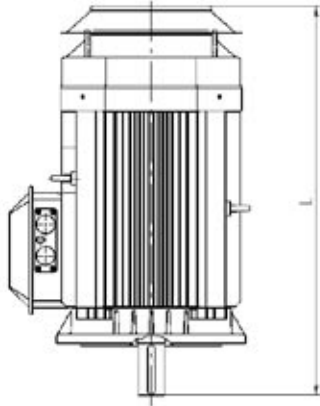

Variant codes	005	183	189	472, 473 572, 573 576, 577	474, 476 477, 574
Motor size	L	L	L	L	L
56	216	-	-	-	-
63	224	-	275	-	-
71	261	352	287	304	352
80	288	373	313	326	373
90 S	318	1)	1)	1)	1)
90 L	343	1)	1)	1)	1)
100 L	385	1)	1)	1)	1)

1) On request.

Variant codes; M2AA	Pole	005	183	189	472, 473 572, 573	474, 476 477, 574 576, 577
Motor size		L	L	L	L	L
112	2-4	400	-	493.5	458.5	543.5
132	2-4	484	-	580.5	542	630.5
160 ¹⁾	2-4	653.5	1015.5	870.5	697	1015.5
180 ²⁾	2-4	653.5	1015.5	870.5	697	1015.5
180 ³⁾	4	694.5	1056.5	911.5	738	1056.5
200 ⁴⁾	4	762.5	1128.5	983.5	806	1128.5
200 ⁵⁾	2-4	783	1149	1004	826.5	1149
225 M	2	824	1233	1088	867	1233
225 S	4	854	1263	1118	897	1263
225 M	4	894	1303	1158	937	1303
250 M	2-4	915	1325	1180	960	1325

1) MA-2, M-2, L-2, M-4, L-4

2) M-2, M-4

3) L-4

4) LA-4

5) L-2, L-4

Accessories

Protective roof and variable speed drives

Protective roof
Variant code 005

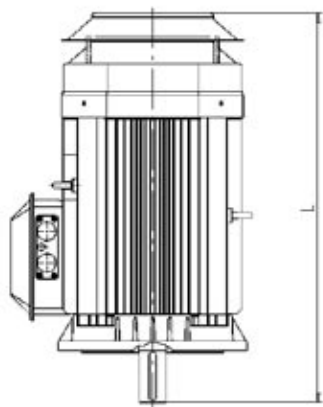

Tacho
Variant codes; 472, 473, 572 and 573

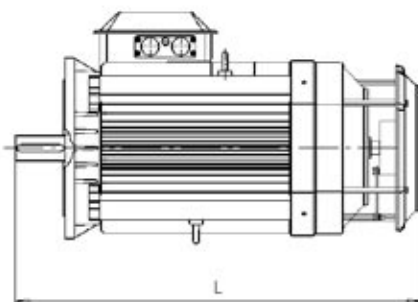

Separate cooling with or without tacho
Variant codes; 183, 474, 476, 477, 189, 574, 576 and 577

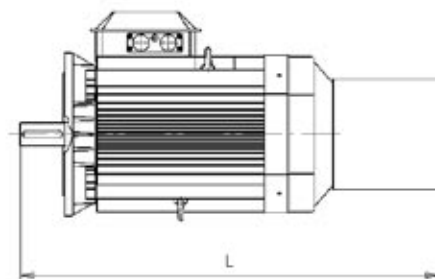

2

Variant codes; M3AA	005	183	189	472, 473 572, 573	474, 476 477, 574 576, 577
Motor size	L	L	L	L	L
112 ¹⁾	400	-	493.5	458.5	543.5
112 ²⁾	428	-	538	487	588
132 ³⁾	484	-	580.5	542	630.5
132 ⁴⁾	522	-	640	580	690
160 ⁵⁾	653.5	1015.5	870.5	697	1015.5
160 ⁶⁾	694.5	1056.5	911.5	738	1056.5
180 ⁷⁾	731	1097	952	774	1097
180 ⁸⁾	751.5	1117.5	972.5	795	1117.5
200 ⁹⁾	825	1234	1089	868	1234
200 ¹⁰⁾	865	1274	1129	908	1274
225 ¹¹⁾	885	1295	1150	930	1295
225 ¹²⁾	910	1320	1175	955	1320
225 ¹³⁾	915	1325	1180	960	1325
225 ¹⁴⁾	940	1350	1205	985	1350
250 ¹⁵⁾	922	1346	1201	969	1346
250 ¹⁶⁾	947	1371	1226	994	1371
280 ¹⁷⁾	922	1346	1201	969	1346
280 ¹⁸⁾	947	1371	1226	994	1371

¹⁾ M-6, M-8,
²⁾ all 112 excl ¹⁾

³⁾ SA-2, S-4, S-6, MA-6, MB-6, S-8,
M-8, S-Two-speed

⁴⁾ all 132 excl ³⁾

⁵⁾ M-2, MA-2, M-4, M-6, M-8, MA-8,
L-2, L-4, L-6, MA-2/4, M-2/4, L-2/4,
M-4/6, M-4/8, LB-2, LB-4

⁶⁾ L-8, L-4/6, L-4/8, LB-6, LB-8.

⁷⁾ M-2, M-4, L-6, L-8, M-2/4, M-4/6,
M-4/8, LB-2

⁸⁾ L-2/4, L-4/6, L-4/8, L-4, LB-4, LB-6, LB-8.

⁹⁾ all 200 excl ¹⁰⁾

¹⁰⁾ MLD-2, MLC-4

¹¹⁾ SMB-2, SMC-2, SM_-2/4

¹²⁾ SMD-2,

¹³⁾ all 225 excl ¹¹⁾ ¹²⁾ ¹⁴⁾

¹⁴⁾ SMD-4

¹⁵⁾ all 250 excl ¹⁶⁾

¹⁶⁾ SMC-2, SMC-4

¹⁷⁾ all 280 excl ¹⁸⁾

¹⁸⁾ SMB-2, SMB-4

Accessories

Slide rails for motor sizes 112-280

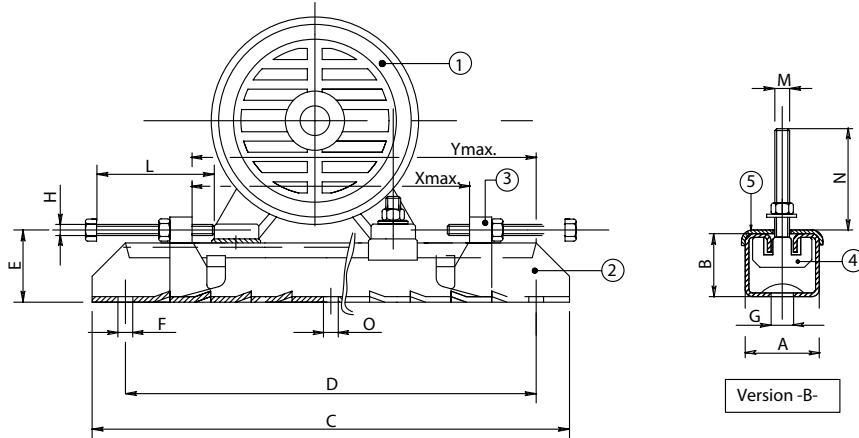

Motorsize	Type	Product code															weight
		3GZV103001-	A	B	C	D	E	F	G	H	L	M	N	O	Xmax	Ymax	
112-132	TT132/10	-12	65	40	530	480	52	17	26	M12	120	M10	45	-	360	420	7,8
160-180	TT180/12	-14	75	42	700	630	57	17	26	M12	120	M12	50	-	520	580	12,0
200-225	TT225/16	-15	82	50	864	800	68	17	27	M16	140	M16	65	17	670	740	20,4
250-280	TT280/20	-16	116	70	1072	1000	90	20	27	M18	150	M20	80	20	870	940	43,0

1) When mounting on a ceiling or on a wall please contact the manufacturer.

Tolerances

A,B	ISO js14
C, CA	+0 -2
D 55-65	ISO m6
DA 45-55	ISO k6
F, FA	ISO h9
H	+0 -0.5
N	ISO js6

Each set includes two complete slide rails including screw for mounting the motor on the rails. Screws for mounting the rails on the foundation are not included. Slide rails are supplied with unmachined lower surfaces and should, prior to tightening down, be supported in a suitable manner.

General purpose aluminum motors in brief, basic design

Size		56	63	71	80	90	100	
Stator and feet	Material Paint colour shade Paint	Diecast aluminum alloy. Loose feet in sizes 71-100; feet integrated with stator in sizes 56-63. Munsell blue 8B 4.5/3.25 / NCS 4822 B05G / RAL 5014 Epoxy polyester powder paint , $\geq 30\mu\text{m}$					Polyester powder paint, $\geq 30\mu\text{m}$	
Bearing end shields	Material Paint colour shade Paint	Diecast aluminum alloy Munsell blue 8B 4.5/3.25 / NCS 4822 B05G / RAL 5014 Epoxy polyester powder paint , $\geq 30\mu\text{m}$					Polyester powder paint, $\geq 30\mu\text{m}$	
Bearings Single-speed motor	D-end N-end	6201-2Z/C3 6201-2Z/C3	6202-2Z/C3 6201-2Z/C3	6203-2Z/C3 6202-2Z/C3	6204-2Z/C3 6203-2Z/C3	6205-2Z/C3 6204-2Z/C3	6306-2Z/C3 6205-2Z/C3	
Bearings Two-speed motor	D-end N-end	6201-2Z/C3 6201-2Z/C3	6202-2Z/C3 6201-2Z/C3	6203-2Z/C3 6202-2Z/C3	6204-2Z/C3 6203-2Z/C3	6205-2Z/C3 6204-2Z/C3	6306-2Z/C3 6205-2Z/C3	
Axially-locked bearings	Inner bearing cover	Spring washer at the N-end.					D-end	
Bearing seals	D-end N-end	V-ring Labyrinth seal.						
Lubrication		Permanently lubricated bearings. Grease for bearing temperatures -30 to +110°C.						
Terminal box	Material Surface treatment Screws	Diecast aluminum alloy. Similar to stator. Steel 5G. Chromated.						
Connections	Knock-out openings Max Cu-area mm ² Terminal box	1 x M16 x Pg11 2.5 Screw terminal, 6 terminals		2 x M20, 2 x Pg16 4		2 x (M20 + M25) 6		
Fan	Material	Polypropylene. Reinforced with 20% glass fibre.						
Fan cover	Material	Steel.						
Stator winding	Material Impregnation Insulation class	Copper. Polyester varnish. Tropicalised. Insulation class F. Temperature rise class B, unless otherwise stated.						
Stator winding temperature sensors		Optional.						
Rotor winding	Material	Diecast aluminum.						
Balancing method		Half key balancing.						
Key ways		Closed keyway						
Heating elements	On request	8 W			25 W			
Enclosure		IP 55.						
Cooling method		IC 411.						
Drain holes		Standard.						

Size	M2AA	112	132	160	180	200	225	250	
Stator	Material	Diecast aluminum alloy.					Extruded aluminum alloy.		
	Paint colour shade Paint	Munsell blue 8B 4.5/3.25 / NCS 4822 B05G / RAL 5014 Polyester powderpaint, $\geq 50\mu\text{m}$							
Feet	Material	Aluminum alloy, integrated with stator.			Cast iron bolted to the stator.				
Bearing end shields	Material	Diecast aluminum alloy			Flanged bearing end shields cast iron, others diecast Aluminum. 280 N-end shields cast iron in 2-pole motors.				
	Paint colour shade Paint	Munsell blue 8B 4.5/3.25 / NCS 4822 B05G / RAL 5014 Polyester powderpaint, $\geq 50\mu\text{m}$							
Bearings Single-speed motor	D-end	6206-2Z/C3	6208-2Z/C3	6309-2Z/C3	6310-2Z/C3	6312/C3	6313/C3	6315/C3	
	N-end	6205-2Z/C3	6206-2Z/C3	6209-2Z/C3	6209-2Z/C3	6209-2Z/C3	6210/C3	6212/C3	
Bearings Two-speed motor	D-end	NA							
	N-end	NA							
Axially-locked bearings	Inner bearing cover	D-end ¹⁾		D-end					
		¹⁾ Foot motor. A spring washer at the N-end presses the motor towards the D-end.							
Bearing seals	D-end	V-ring					Outer and inner V-rings.		
	N-end	Labyrinth seal.					Outer and inner V-rings.		
Lubrication		Permanently lubricated shielded bearings. Grease temperature range -40 to +160°C.					Valve lubrication. Grease temp. range -40 to 150°C.		
Terminal box	Material	Diecast aluminum alloy, base integrated with stator.					Deep-drawn steel sheet,		
	Surface treatment	Similar to stator.					bolted to stator.		
	Screws	Steel 5G. Galvanised.					Phosphated. Polyester paint.		
Connections	Knock-out openings	2 x (M25 + M20)		2 x (2 x M40 + M16)			2 x FL13, 2 x M40		
	Flange-openings						2 x FL 21, 2 x M63 (voltage code S)		
Terminal box	Screws	M5		M6			M10		
	Max Cu-area mm ²	10		35			70		
		Cable lugs, 6 terminals							
Fan	Material	Polypropylene. Reinforced with 20% glass fibre.							
Fan cover	Material	Polypropylene.			Steel sheet. Also two-speed sizes 112 and 132 M.				
	Surface treatment	Phosphated. Polyester paint.							
Stator winding	Material	Copper.							
	Impregnation	Polyester varnish. Tropicalised.							
	Insulation class	Insulation class F. Temperature rise class B, unless otherwise stated.							
Stator winding temperature sensors		Optional.					PTC thermistors, 150°C, 3 in series.		
Rotor winding	Material	Diecast aluminum.							
Balancing method		Half key balancing.							
Key ways		Closed keyway							
Heating elements	On request	25 W			50 W				
Enclosure		IP 55.							
Cooling method		IC 411.							
Drain holes		Drain holes with closable plastic plugs, open on delivery.							

Size	M3AA	112	132	160	180	200	225	250	280
Stator	Material	Diecast aluminum alloy.				Extruded aluminum alloy.			
	Paint colour shade Paint	Munsell blue 8B 4.5/3.25 / NCS 4822 B05G / RAL 5014 Polyester powderpaint, $\geq 50\mu\text{m}$							
Feet	Material	Aluminum alloy, integrated with stator.				Aluminum ¹⁾ alloy, bolted to the stator. ¹⁾ 250-2, cast iron			Cast iron
Bearing end shields	Material	Diecast aluminum alloy			Flanged bearing end shields cast iron, others diecast Aluminum.				Cast iron
	Paint colour shade Paint	Munsell blue 8B 4.5/3.25 / NCS 4822 B05G / RAL 5014 Polyester powderpaint, $\geq 50\mu\text{m}$							
Bearings Single-speed motor	D-end	6206-2Z/C3	6208-2Z/C3	6309-2Z/C3	6310-2Z/C3	6312/C3	6313/C3	6315/C3	6316/C3 ¹⁾
	N-end ²⁾	6205-2Z/C3	6206-2Z/C3	6209-2Z/C3	6209-2Z/C3	6210/C3	6212/C3	6213/C3	6213/C3
	N-end ³⁾	6206-2Z/C3	6208-2Z/C3						
		¹⁾ 6315/C3 for 2-pole motors ²⁾ M3AA 112: M-6, M-8, M3AA 132: SA-2, S-4, S-6, MA-6, MB-6, S-8 and M-8. ³⁾ All motors sizes 112-132 not included in ²⁾ .							
Bearings Two-speed motor	D-end	6206-2Z/C3	6208-2Z/C3	6309-2Z/C3	6310-2Z/C3	6312/C3	6313/C3	6315/C3	NA
	N-end ¹⁾ N-end ²⁾	6206-2Z/C3 6205-2Z/C3	6206-2Z/C3 6206-2Z/C3	6209-2Z/C3	6209-2Z/C3	6210/C3	6212/C3	6213/C3	
		¹⁾ M3AA 112, M3AA 132M.			²⁾ M3AA 132S				
Axially-locked bearings	Inner bearing cover	D-end ¹⁾ ¹⁾ Foot motor. A spring washer at the N-end presses the motor towards the D-end.		D-end					
Bearing seals	D-end	V-ring				Outer and inner V-rings.			
	N-end	Labyrinth seal. Except two-speed motors 112-132M, outer and inner V-rings.				Outer and inner V-rings.			
Lubrication		Permanently lubricated shielded bearings. Grease temperature range -40 to +160°C.				Valve lubrication. Grease temp. range -40 to 150°C.			
Terminal box	Material Surface treatment Screws	Diecast aluminum alloy, base integrated with stator. Similar to stator. Steel 5G. Galvanised.				Deep-drawn steel sheet, bolted to stator. Phosphated. Polyester paint.			
Connections	Knock-out openings Flange-openings	2 x (M25 + M20)		2 x (2 x M40 + M16)		2 x FL13, 2 x M40 2 x FL 21, 2 x M63 (voltage code S)			2 x FL21 2 x M63 1 x M16
	Screws Max Cu-area mm ²	M5 10		M6 35		M10 70			
Terminal box		Cable lugs, 6 terminals							
Fan	Material	Polypropylene. Reinforced with 20% glass fibre.							
Fan cover	Material	Polypropylene.			Steel sheet. Also two-speed sizes 112 and 132 M.				
	Surface treatment	Phosphated. Polyester paint.							
Stator winding	Material Impregnation Insulation class	Copper. Polyester varnish. Tropicalised. Insulation class F. Temperature rise class B, unless otherwise stated.							
Stator winding temperature sensors		Optional.				PTC thermistors, 150°C, 3 in series.			
Rotor winding	Material	Diecast aluminum.							
Balancing method		Half key balancing.							
Key ways		Closed keyway							
Heating elements	On request	25 W			50 W				
Enclosure		IP 55.							
Cooling method		IC 411.							

ABB Motors' total product offer

ABB offers several comprehensive ranges of AC motors and generators. We manufacture synchronous motors for even the most demanding applications, and a full range of low and high voltage induction motors. Our in-depth knowledge of virtually every type of industrial processing ensures we always specify the best solution for your needs.



Low voltage motors and generators

General purpose motors for standard applications

- Aluminum motors
- Steel motors
- Cast iron motors
- Open drip proof motors
- Global motors
- Brake motors
- Single phase motors
- Integral motors

Process performance motors for more demanding applications

- Aluminum motors
- Cast iron motors
- Motors for high ambient temperatures

NEMA motors

High voltage and synchronous motors and generators

- High voltage cast iron motors
- Induction modular motors
- Slip ring motors
- Motors for hazardous areas
- Servomotors
- Synchronous motors and generators
- DC motors and generators

Motors for hazardous areas

- Flameproof motors
- Increased safety motors
- Non-sparking motors
- Dust ignition proof motors

Marine motors

- Aluminum motors
- Steel motors
- Cast iron motors
- Open drip proof motors

Other applications

- Permanent magnet motors
- High speed motors
- Wind turbine generators
- Smoke venting motors
- Water cooled motors
- Motors for roller table drives

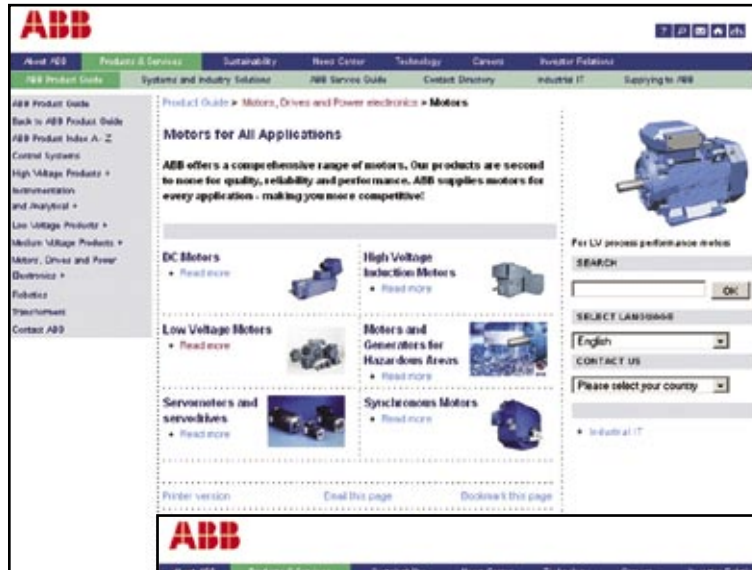

- Motors & Drives**
- => Low Voltage Motors
 - => **General purpose motors**
 - Aluminum motors
 - Steel motors
 - Cast iron motors
 - Global motors
 - Open drip proof motors
 - Brake motors
 - Single phase motors
 - Integral motors
 - Process performance motors
 - Motors for hazardous areas
 - Marine motors
 - Other applications
 - Roller table motors
 - Water cooled motors
 - Permanent magnet motors
 - High speed motors
 - Generators

Low Voltage Motors

Manufacturing sites (*) and some of the larger sales companies.

Australia

ABB Industry Pty Ltd
2 Douglas Street
Port Melbourne,
Victoria, 3207
Tel: +61 (0) 3 9644 4100
Fax: +61 (0) 3 9646 9362

Austria

ABB AG
Clemens Holzmeisterstrasse 11 B
AT-1810 Wien
Tel: +43 (0) 1 601 090
Fax: +43 (0) 1 601 09 8305

Belgium

Asea Brown Boveri S.A.-N.V.
Hoge Wei 27
BE -1930 Zaventem
Tel: +32 (0) 2 718 6311
Fax: +32 (0) 2 718 6657

Canada

ABB Inc., BA Electrical Machines
10300 Henri-Bourassa Blvd, West,
Saint-Laurent, Quebec
Canada H4S 1N6
Tel: +1 514 832-6583
Fax: +1 514 332-0609

China*

ABB Shanghai Motors
Company Limited
8 Guang Xing Rd., Rong Bei
Town, Songjiang County,
Shanghai 201613
Tel: +86 21 5778 0988
Fax: +86 21 5778 1364

Chile

Asea Brown Boveri S.A.
P.O.Box 581-3
Santiago
Tel: +56 (0) 2 5447 100
Fax: +56 (0) 2 5447 405

Denmark

ABB A/S
Automation Technology Electrical
Machines
Petersmindevej 1
DK-5000 Odense C
Tel: +45 65 477 070
Fax: +45 65 477 713

Finland*

ABB Oy
LV Motors
P.O.Box 633
FI-65101 Vaasa
Tel: +358 (0) 10 22 11
Fax: +358 (0) 10 22 47372

France

ABB Automation
Rue du Général de Gaulle
Champagne-sur-Seine
FR-77811 Moret-sur-Loing Cedex
Tel: +33 (0) 1 60 746 500
Fax: +33 (0) 1 60 746 565

Germany

ABB Automation Products GmbH
Edisonstrasse 15
DE-68623 Lampertheim
Tel: +49 (0) 6206 503 503
Fax: +49 (0) 6206 503 600

Hong Kong

ABB (Hong Kong) Ltd.
Tai Po Industrial Estate,
3 Dai Hei Street,
Tai Po, New Territories,
Hong Kong
Tel: +852 2929 3838
Fax: +852 2929 3505

India*

ABB Ltd.
32, Industrial Area, N.I.T
Faridabad 121 001
Tel: +91 (0) 129 502 3001
Fax: +91 (0) 129 502 3006

Indonesia

PT. ABB Sakti Industri
JL. Gajah Tunggal Km.1
Jatiuwung, Tangerang 15136
Banten, Indonesia
Tel: + 62 21 590 9955
Fax: + 62 21 590 0115 - 6

Ireland

Asea Brown Boveri Ltd
Components Division
Belgard Road
Tallaght, Dublin 24
Tel: +353 (0) 1 405 7300
Fax: +353 (0) 1 405 7327

Italy*

ABB SACE SpA
LV Motors
Via Della Meccanica, 22
IT-20040 Caponago - MI
Tel: +39 02 959 6671
Fax: +39 02 959 667216

Japan

ABB K.K.
26-1 Cerulean Tower
Sakuragaoka-cho, Shibuya-ku
Tokyo 150-8512
Tel: +81 (0) 3 578 46251
Fax: +81 (0) 3 578 46260

Korea

ABB Korea Ltd.
7-9fl, Oksan Bldg., 157-33
Sungshung-dong, Kangnam-ku
Seoul
Tel: +82 2 528 2329
Fax: +82 2 528 2338

Malaysia

ABB Malaysia Sdn. Bhd.
Lot 608, Jalan SS 13/1K
47500 Subang Jaya, Selangor
Tel: +60 3 5628 4888
Fax: +60 3 5631 2926

Mexico

ABB México, S.A. de C.V.
Apartado Postal 111
CP 54000 Tlalnepantla
Edo. de México, México
Tel: +52 5 328 1400
Fax: +52 5 390 3720

The Netherlands

ABB B.V.
Dept. LV motors (APP2R)
P.O.Box 301
NL-3000 AH Rotterdam
Tel: +31 (0) 10 4078 879
Fax: +31 (0) 10 4078 345

Norway

ABB AS
P.O.Box 154 Vollebekk
NO-0520 Oslo
Tel: +47 22 872 000
Fax: +47 22 872 541

Singapore

ABB Industry Pte Ltd
2 Ayer Rajah Crescent
Singapore 139935
Tel: +65 6776 5711
Fax: +65 6778 0222

Spain*

ABB Automation Products S.A.
Division Motores
P.O.Box 81
ES-08200 Sabadell
Tel: +34 93 728 8500
Fax: +34 93 728 8741

Sweden*

ABB Automation Technologies AB
LV Motors
SE-721 70 Västerås
Tel: +46 (0) 21 329 000
Fax: +46 (0) 21 329 140

Switzerland

ABB Schweiz AG
Normelec
Badenerstrasse 790
Postfach
CH-8048 Zürich
Tel: +41 (0) 58 586 0000
Fax: +41 (0) 58 586 0603

Taiwan

ABB Ltd.
6F, No. 126, Nanking East Road,
Section 4i
Taipei, 105 Taiwan, R.O.C.
Tel: +886 (0) 2 2577 6090
Fax: +886 (0) 2 2577 9467

Thailand

ABB Limited (Thailand)
161/1 SG Tower,
Soi Mahadlekluang 3,
Rajdamri, Bangkok 10330
Tel: +66 2 665 1000
Fax: +66 2 665 1042

The United Kingdom

ABB Automation Ltd
9 The Towers, Wilmslow Road
Didsbury
Manchester, M20 2AB
Tel: +44 (0) 161 445 5555
Fax: +44 (0) 161 448 1016

USA

ABB Inc.
Low Voltage Motors
16250 W. Glendale Drive
New Berlin, WI 53151
Tel: +1 262 785 3200
Fax: +1 262 785 8628

Venezuela

Asea Brown Boveri S.A.
P.O.Box 6649
Carmelitas,
Caracas 1010A
Tel: +58 (0) 2 238 2422
Fax: +58 (0) 2 239 6383



<http://www.abb.com/motors&drives>
<http://online.abb.com/motors&drives>